

Group: **Chiller**

Part Number: **5714335Y**

Date: **August 1996**

## Packaged Water Chiller with Screw Compressors

**Models:** ALS125A thru 204A  
ALS205A thru 280A  
ALS300A thru 380A  
PFS150A thru 200A

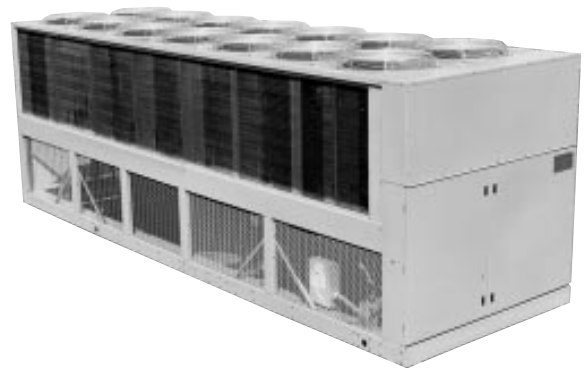

# Table of Contents

<b>Introduction</b> .....	4	<b>Electronic Expansion Valve</b> .....	22
<b>General Description</b> .....	4	Overview .....	22
<b>Control Panel Features</b> .....	5	Exv Superheat Control .....	22
<b>Software Identification</b> .....	5	Forced EXV Position Change .....	22
<b>Controller Layout</b> .....	6	EXV Evaporator Pressure Control .....	23
<b>Component Data</b> .....	6	<b>Chilled Water Reset Options</b> .....	23
Microprocessor Control Board .....	6	Chilled Water Reset (Remote 4-20mA) .....	23
Analog/Digital Input Board (ADI Board) .....	7	Ice Mode .....	23
Output Board .....	7	Network Reset .....	23
Electronic Expansion Valve Board (EXV Board) .....	7	Return Water Reset .....	24
Analog Output Board (AOX Board) .....	8	Remote Demand Limit .....	24
Keypad/Display .....	8	Network Demand Limit .....	24
<b>Sensors And Transducers</b> .....	9	Soft Loading .....	24
Standard Sensors .....	9	Max Pull Down .....	24
Optional Sensor Packages .....	9	<b>Condenser Fan Control</b> .....	24
Thermistor Sensors .....	9	Condenser Fan Staging .....	24
Pressure Transducers .....	11	Head Pressure Control .....	24
Liquid Presence Sensor .....	11	Lift Pressure Calculation .....	25
<b>Sensor Locations</b> .....	12	Lift Pressure Dead Band .....	25
Analog Inputs .....	13	Condenser Fan Stage Up .....	26
Digital Inputs .....	15	High Pressure Stage Up .....	26
Analog Outputs .....	16	Condenser Fan Stage Down .....	26
Digital Outputs .....	17	SpeedTrol Logic .....	26
<b>Installation</b> .....	18	<b>Pumpdown</b> .....	26
Controller Calibration .....	18	Automatic Pumpdown .....	26
Field Wiring .....	18	Manual Pumpdown .....	27
Analog Sensors and Transducers .....	18	Service Pumpdown .....	27
Digital Input Signals .....	18	<b>Safety Systems</b> .....	27
Digital Outputs .....	18	System Alarms .....	27
Interlock Wiring .....	18	Loss of Chw Flow .....	27
External Alarm Circuit .....	18	Bad Phase/Voltage .....	27
Power Wiring .....	18	No 5VDC @AI#5 .....	27
Power Supplies .....	18	Chilled Water Freeze Protect .....	27
Demand Limit and Chilled Water Reset Signals .....	18	Bad Leaving Chilled Water Sensor .....	27
Communication Ports .....	18	Circuit Alarms .....	27
Modem Kit .....	19	Mechanical High Pressure .....	27
Telephone Line for Remote Modem Access .....	19	High Condenser Pressure .....	27
<b>Unit Sequence of Operation</b> .....	19	High Condenser Pressure Stage Down .....	27
Off Conditions .....	19	High Condenser Pressure Stage Hold .....	28
Start-up .....	19	No Liquid Start .....	28
Waiting for Load .....	19	No Liquid Run .....	28
Start Requested .....	19	Can't Start - Low Evaporator Pressure .....	28
Prepurge .....	19	Low Evaporator Pressure .....	28
Opened EXV .....	20	Freeze Protect Stage Down and	
Low Ambient Start .....	20	Freeze Stat Protect .....	28
Cool Stage (0 through 8) .....	20	Failed Pre-Purge .....	28
<b>Compressor Control</b> .....	20	Failed EXV or Low Refrigerant Charge .....	28
Normal Compressor Staging Logic .....	20	Failed Low Ambient Start .....	28
Project-Ahead Calculation .....	21	Can't Pump Down .....	28
Interstage Timer .....	21	Bad Evaporator Pressure Sensor .....	28
Anti-Cycle Timer .....	21	Bad Condenser Pressure Sensor .....	28
Compressor Heater Control .....	21	Wait Flooded .....	28
<b>Lead-Lag Of Refrigerant Circuits</b> .....	22	Wail Flooded .....	28
Automatic Lead-Lag .....	22	<b>MicroTech Controller Test Procedures</b> .....	29
Manual Lead-Lag .....	22	Service Test (Digital Outputs) .....	29
		Service Test (Digital Inputs) .....	29

<b>Keypad/Display</b> .....	29	Troubleshooting Solid-State Relays .....	34
Overview .....	29	MCB Replacement .....	34
Status Category .....	29	Connecting The Communications Trunk .....	35
Control Category .....	29	Communications Cable Check .....	35
Alarm Category .....	30	Level-1 Controller Connection .....	35
Display Format .....	30	Level-2 Controller Connection .....	35
<b>MicroTech Component Test Procedures &amp; ALS Units</b> .....	30	<b>Keypad Key Functions</b> .....	36
Status LED Diagnostics .....	30	Keypad Password .....	36
Red LED Remains On .....	30	Category Group .....	36
Red and Green LEDs Off .....	30	Menu Group .....	37
Troubleshooting Power Problems .....	30	Item Group .....	37
Troubleshooting Communications Problems .....	31	Action Group .....	37
Troubleshooting the Keypad/Display Interface .....	31	Example of Keypad Operation .....	37
Display is Hard to Read .....	31	<b>Personal Computer Specification</b> .....	37
Back Light Not Lit .....	31	<b>MicroTech Menu Structure</b> .....	38
Display Is Blank or Garbled .....	31	Status Menus .....	38
Troubleshooting Analog Inputs .....	32	Control Menus .....	38
Analog Input Not Read by the MCB .....	32	Alarm Menus .....	38
Troubleshooting Digital Inputs .....	32	<b>Schematics And Drawings</b> .....	60
Digital Input Not Read by the MCB .....	32	Control Cabinet Layout .....	60
Troubleshooting Analog Outputs .....	32	Wiring Legend .....	63
Analog Output Device Is Not Operating Correctly ...	32	PFS Unit Control .....	64
Troubleshooting Output Boards .....	33	PFS 8-Stage Output .....	65
One LED Out .....	33	PFS MicroTech .....	66
All LEDs Out .....	33	ALS Unit Control .....	67
LED Lit, Output Not Energized .....	33	ALS 8-Stage Output .....	68
Output Energized, LED Not Lit .....	33	ALS MicroTech .....	69
Contact Chatter .....	33	ALS Field Wiring .....	70

# Introduction

This manual provides installation, setup and troubleshooting information for the MicroTech controller provided on McQuay screw compressor chillers. Please refer to installation manual IM548 for unit application information as well as water and refrigerant piping details. All operating descriptions contained in this manual are based on MicroTech controller software version SC2-X18B, SC3XX19 and SC4XX19A. Chiller operating characteristics and menu selections may vary with other versions of controller software. Contact McQuayService for software update information.

## ⚠ CAUTION

This equipment generates, uses and can radiate radio frequency energy and if not installed and used in accordance with the instructions manual, may cause interference to radio communications. It has been tested and found to comply with the limits for a class A digital device, pursuant to part 15 of the FCC rules. These limits are designed to provide reasonable protection against harmful interference when the equipment is operated in a commercial environment.

Operation of this equipment in a residential area is likely to cause harmful interference in which case the user will be required to correct the interference at his own expense. McQuay International disclaims any liability resulting from any interference or for the correction thereof.

## ⚠ CAUTION

The McQuay MicroTech control panel contains static sensitive components. A static discharge while handling electronic circuit boards may cause damage to the components.

To prevent such damage during service involving board replacement, McQuay recommends discharging any static electrical charge by touching the bare metal inside the panel before performing any service work.

## ⚠ CAUTION

Excessive moisture in the control panel can cause hazardous working conditions and improper equipment operation.

When servicing equipment during rainy weather conditions, the electrical devices and MicroTech components housed in the main control panel must be protected.

The MicroTech controller is designed to operate within an ambient temperature range of minus 40 to plus 185°F and a maximum relative humidity of 95% (non-condensing).

# General Description

The MicroTech Unit Control Panel, available on all McQuay ALS and PFS products, contains a Model 250 Microprocessor based controller which provides all monitoring and control functions required for the safe, efficient operation of the unit. The operator can monitor all operating conditions by using the panel's built in 2 line by 16 character display and keypad or by using an IBM compatible computer running McQuay Monitor software. In addition to providing all normal operating controls, the MicroTech controller monitors all safety devices on the unit and will shut the system down and close a set of alarm contacts if an alarm condition develops.

Important operating conditions at the time an alarm occurs are retained in the controller's memory to aid in troubleshooting and fault analysis. The system is protected by a password scheme which only allows access by authorized personnel. A valid password must be entered into the panel keypad by the operator before any set points may be altered.

Table 1.

Unit Identification	
ALS	Air Cooled Chiller with Screw Compressors
PFS	Water Cooled Chiller with Screw Compressors

## Control Panel Features

- Flexible control of leaving chilled water with convenient reset capability.
- Enhanced head pressure control on air cooled units resulting in increased total unit SEER.
- Convenient, easy to read 2 line by 16 character display for plain English readout of operating temperatures and pressures, operating modes or alarm messages.
- Keypad adjustment of unit safeties such as low water temperature cutout, high pressure cutout, suction pressure cutout, and freeze protection. The operator can use the keypad to monitor various operating conditions, set points or alarm messages.
- Security password protection against unauthorized changing of set points and other control parameters.
- Complete plain English diagnostics to inform the operator of system warnings and alarms. All alarms are time and date stamped so there is no guessing of when the alarm

condition occurred. In addition, the operating conditions that existed at the instant of shutdown can be recalled to aid in isolating the cause of the problem.

- Soft loading feature to reduce electrical consumption and peak demand charges during chilled water loop pulldown.
- Easy integration into building automation systems via separate 4-20 milliamp signals for chilled water reset and demand limiting. McQuay's Open Protocol feature is fully supported.
- Flexible internal time clock for on/off scheduling.
- Communications capabilities for local system monitoring, changing of set points, trend logging, remote reset, alarm and event detection, via IBM compatible PC. The optional modem kit supports the same features from an off-site PC running McQuay Monitor software.
- Special service modes may be used to override automatic unit staging during system checkout and service.

## Software Identification

Controller software is factory installed and tested in each panel prior to shipment. The software is identified by a program code which is printed on a small label attached to the controller. The software version may also be displayed on the keypad/display by viewing the last menu item in the Misc. Setup menu.

The software "version" is the 5th & 6th digit of the software number. In the example, the version is "17" and the revision to the software is "G".

Revisions are released in alphabetical order.

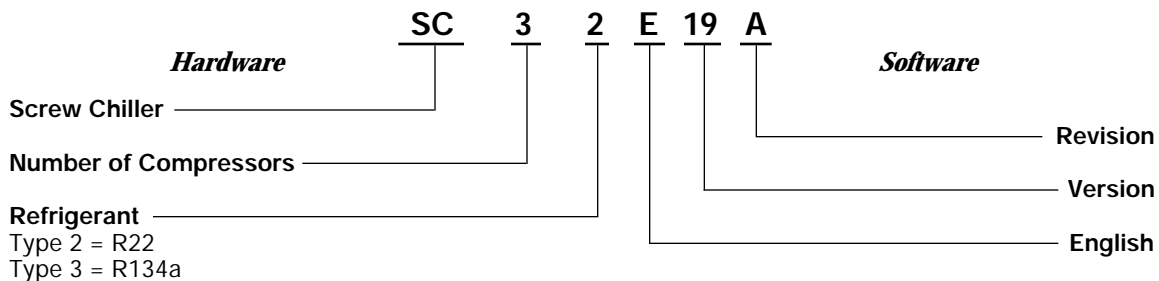

# Controller Layout

All major MicroTech components are mounted inside the control section side of the unit's control cabinet. The individual components are interconnected by ribbon cables, shielded multi-conductor cables or discrete wiring. Power for the system is provided by transformers T-2 and T-4. All field wiring must enter the control cabinet through the

knockouts provided and be terminated on field wiring terminal strips. The standard ALS keypad/display is located inside the control cabinet for protection from the weather while the PFS Keypad/Display is accessible through the exterior of the control cabinet. See Figure 1 for typical control cabinet layout.

Figure 1. Typical control cabinet layout — 2 compressor unit

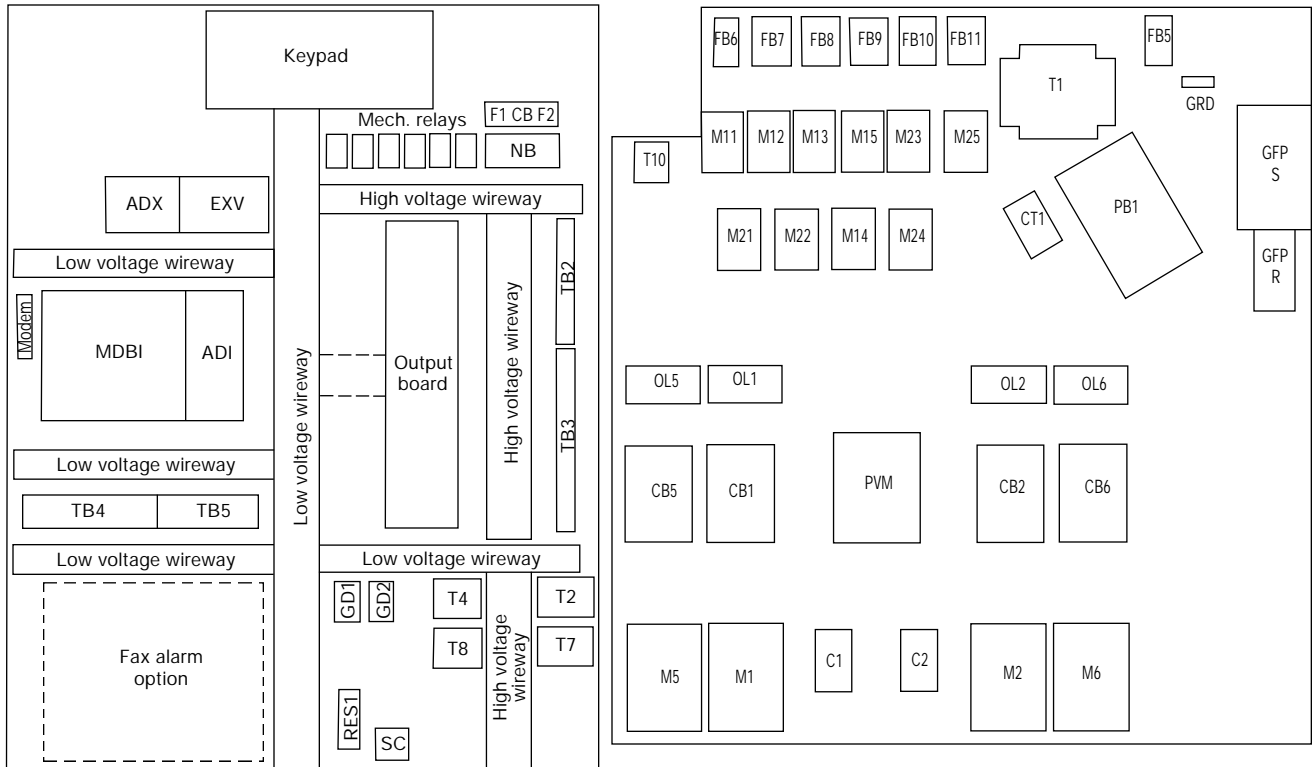

## Component Data

### Microprocessor Control Board (MCB1)

The Model 250 Microprocessor Control Board contains the electronic hardware and software required to monitor and control the unit. It receives input from the ADI Board and sends commands to the Output Board to maintain the unit's optimum operating mode for the current conditions. Status lights are mounted on the control board to indicate the operating condition of the microprocessor.

Figure 2. MCB1

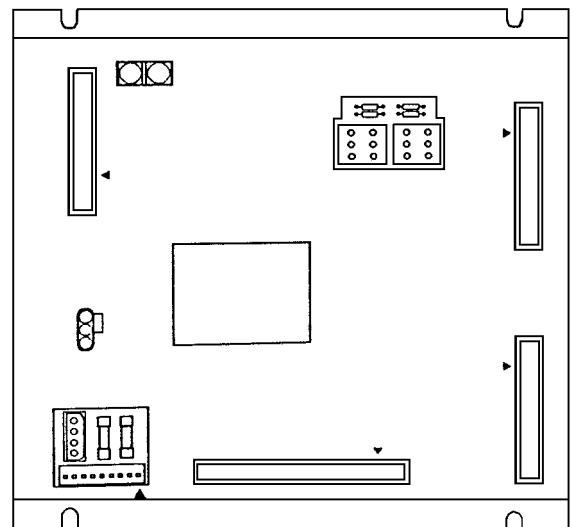

## Analog/Digital Input Board (ADI Board)

The ADI Board provides low voltage power for the temperature and pressure sensors. It also provides electrical isolation between the Microprocessor Control Board and all 24V switch inputs. LEDs are furnished on the board to give a

visual indication of the status of all digital inputs. All analog and digital signals from sensors, transducers and switches are received by the ADI Board and then sent to the Microprocessor Control Board for interpretation.

Figure 3. ADI

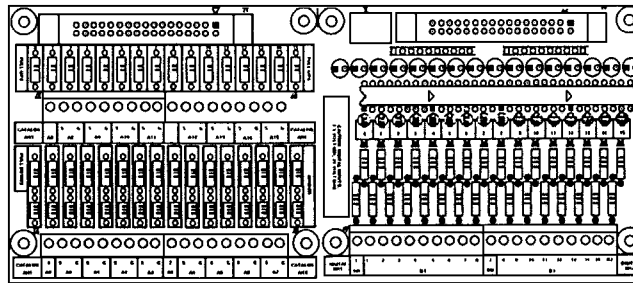

## Output Board

The Output Board contains up to 24 solid state relays which are used to control all compressors, condenser fans, solenoid valves and alarm annunciation.

It receives control signals from the Microprocessor Control Board through a 50 conductor ribbon cable.

Figure 4. Output board

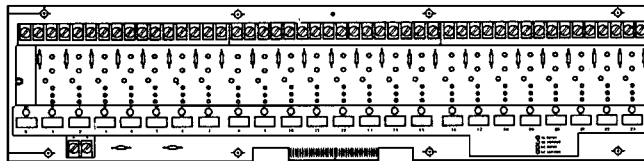

## Electronic Expansion Valve Board (EXV Board)

Each EXV Board will directly control up to two electronic expansion valves. The boards may be cascaded together for

units with more than two EXV's. Control instructions for the board are generated by the M250 controller.

Figure 5. EXV board

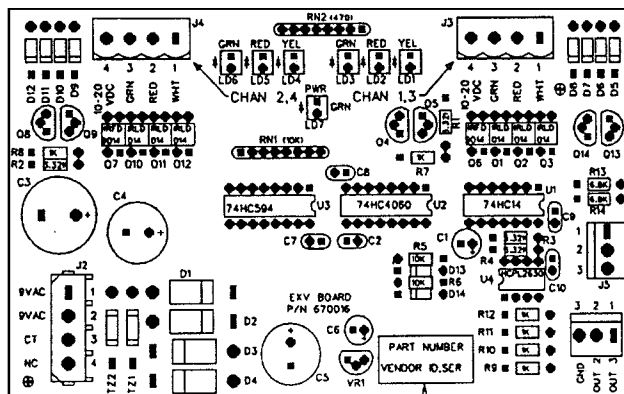

## Analog Output Board (AOX Board) (With Optional SpeedTrol)

The AOX Board converts control instructions from the M250's expansion bus into an analog control signal suitable for

driving a variable speed condenser fan. Each AOX Board is factory set via jumper to provide an output signal of 0 - 10 VDC.

Figure 6. AOX board

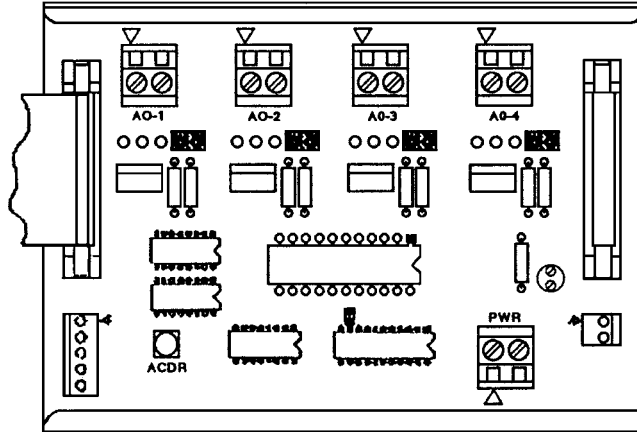

## Keypad/Display

The Keypad/Display is the primary operator interface to the unit. All operating conditions, system alarms and set points can be monitored from this display and all adjustable set

points can be modified from this keyboard if the operator has entered a valid operator password.

Figure 7. Keypad display

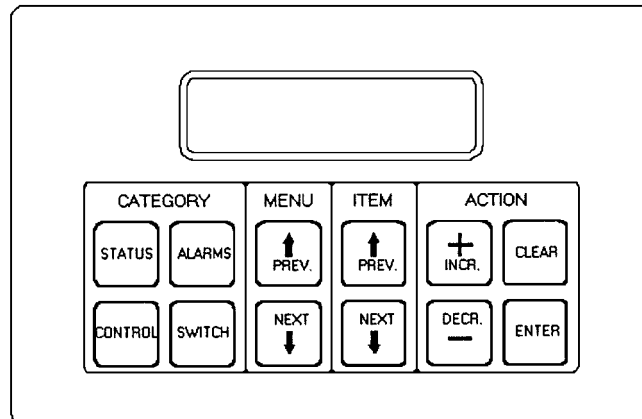



# Sensors and Transducers

## Standard Sensors

Evaporator Leaving Water Temperature  
Evaporator Refrigerant Pressure, Circuit #1, 2, 3 & 4  
Condenser Refrigerant Pressure, Circuit #1, 2, 3 & 4  
Saturated Suction Temperature, Circuit #1, 2, 3 & 4

Liquid Line Temperature, Circuit #1, 2, 3 & 4  
(Provides direct display of subcooling and superheat)  
Entering Evaporator Water Temperature  
Ambient O.A. Temperature

## Optional Sensor Packages

### Water cooled units only:

Entering Condenser Water Temperature  
Leaving Condenser Water Temperature

### Air and water cooled units:

Percent Unit Amps on 2 Compressor Units  
(Percent total unit amperage including compressors and condenser fans. Does not include externally powered equipment such as water pumps.)

Percent Compressor Amps On 3 Compressor Units And  
Percent Circuit Amps (1 & 3, 2 & 4) On 4 Compressor Units.

## Thermistor Sensors

MicroTech panels use a negative temperature coefficient thermistor for temperature sensing. A normal sensor will measure 3000 ohms at 77°F.

*Figure 8. Thermistor sensor*

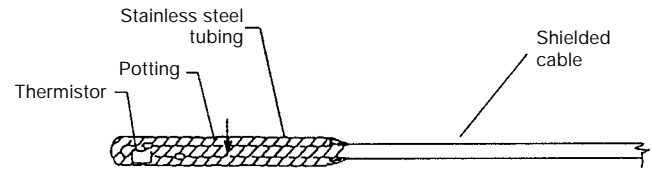

Table 2. MicroTech thermistors

°F	Ohms	Volts	°F	Ohms	Volts	°F	Ohms	Volts
15	16,104	4.145	77	3000	2.373	139	761	0.932
16	15,627	4.124	78	2927	2.343	140	746	0.917
17	15,166	4.102	79	8357	2.313	141	731	0.902
18	14,720	4.080	80	2789	2.283	142	717	0.888
19	14,288	4.057	81	2723	2.253	143	703	0.874
20	13,871	4.034	82	2658	2.223	144	689	0.859
21	13,467	4.011	83	2595	2.194	145	676	0.846
22	13,076	3.988	84	2534	2.164	146	662	0.831
23	12,698	3.964	85	2474	2.135	147	649	0.818
24	12,333	3.940	86	2416	2.106	148	637	0.805
25	11,979	3.915	87	2360	2.077	1490	625	0.792
26	11,636	3.890	88	2305	2.049	150	613	0.779
27	11,304	3.865	89	2251	2.020	151	601	0.766
28	10,983	3.839	90	2199	1.992	152	589	0.753
29	10,672	3.814	91	2149	1.965	153	578	0.741
30	10,371	3.788	92	2099	1.937	154	567	0.729
31	10,079	3.761	93	2051	1.909	155	556	0.717
32	9797	3.734	94	2004	1.882	156	546	0.706
33	9523	3.707	95	1959	1.855	157	535	0.694
34	9258	3.608	96	1914	1.828	153	525	0.683
35	9002	3.653	97	1871	1.802	159	516	0.673
36	8753	3.625	98	1829	1.775	160	506	0.661
37	8512	3.597	99	1788	1.750	161	496	0.650
38	8278	3.569	100	1747	1.724	162	487	0.640
39	8052	3.540	101	1708	1.698	163	478	0.629
40	7832	3.511	102	1670	1.673	164	469	0.619
41	7619	3.482	103	1633	1.648	165	461	0.610
42	7413	3.453	104	1597	1.624	166	452	0.599
43	7213	3.424	105	1562	1.600	167	444	0.590
44	7019	3.394	106	1528	1.576	168	436	0.580
45	6831	3.365	107	1494	1.552	169	428	0.571
46	6648	3.335	108	1461	1.528	170	420	0.561
47	6471	3.305	109	1430	1.505	171	413	0.553
48	6299	3.274	110	1398	1.482	172	405	0.544
49	6133	3.244	111	1368	1.459	173	398	0.535
50	5971	3.213	112	1339	1.437	174	391	0.527
51	5814	3.183	113	1310	1.415	175	384	0.518
52	5662	3.152	114	1282	1.393	176	377	0.510
53	5514	3.121	115	1254	1.371	177	370	0.501
54	5371	3.078	116	1228	1.350	178	364	0.494
55	5231	3.059	117	1201	1.328	179	357	0.485
56	5096	3.028	118	1176	1.308	180	351	0.478
57	4965	2.996	119	1151	1.287	181	345	0.471
59	4714	2.934	121	1103	1.247	183	333	0.456
60	4594	2.902	122	1080	1.227	184	327	0.448
61	4477	2.871	123	1058	1.208	185	321	0.441
62	4363	2.839	124	1036	1.189	186	316	0.435
63	4253	2.808	125	1014	1.170	187	310	0.427
64	4146	2.777	126	993	1.151	188	305	0.421
65	4042	2.745	127	973	1.133	189	299	0.413
66	3941	2.714	128	953	1.115	190	294	0.407
67	3842	2.682	129	933	1.076	191	289	0.400
68	3748	2.651	130	914	1.079	192	284	0.394
69	3655	2.620	131	895	1.062	193	280	0.389
70	3565	2.589	132	877	1.045	194	275	0.382
71	3477	2.558	133	859	1.028	195	270	0.376
72	3392	2.527	134	842	1.012	196	266	0.371
73	3309	2.496	135	825	0.995	197	261	0.364
74	3328	2.465	136	809	0.980	198	257	0.359
75	3150	2.434	137	792	0.963	199	252	0.353
76	3074	2.404	138	777	0.948	200	248	0.348

## Pressure Transducers

These transducers are selected for a specific operating range and provide an output signal which is proportional to the sensed pressure. The typical range for evaporator sensors is 0 to 150 psig with a resolution of 0.1 psig. Condenser pressure sensors have a range of 0 to 450 psi and a resolution

of 0.5 psig. The pressure transducers require an external 5 VDC power supply to operate which is provided by the MicroTech controller. This connection should not be used to power any additional devices.

Figure 9.

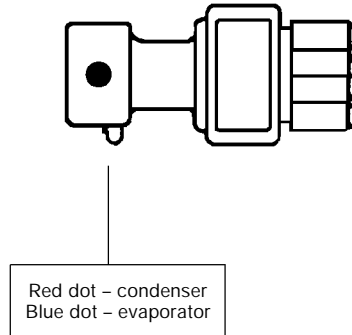

## Liquid Presence Sensor

The presence of liquid refrigerant is determined by a liquid level sensor mounted at the liquid injection port in the compressor casting. Whenever the glass prism sensor tip is

in contact with liquid, the sensor output signal will be high (>7VAC). If no liquid is detected, the output will be low (0VAC).

Figure 10.

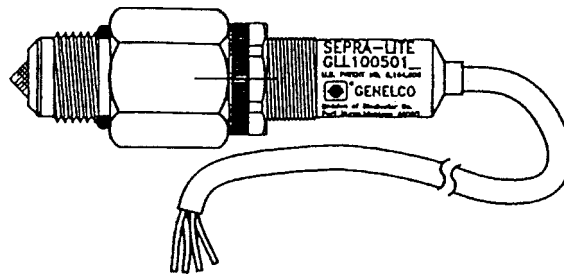

# Sensor Locations – 2 Compressor Unit

Table 3.

Sensor	Description	Part Number
S00	Evaporator Leaving Water Temperature	605830-03
S01	Evaporator Pressure Transducer Circuit #1	658168B-011
S02	Evaporator Pressure Transducer Circuit #2	658168B-011
S03	Condenser Pressure Transducer Circuit #1	658168B-021
S04	Condenser Pressure Transducer Circuit #2	658168B-021
S06	Evaporator Water Temperature Reset (Outdoor Air or Zone)	N/A
S07	Demand Limit	N/A
S08	Evaporator Entering Water Temperature	705830B-02
S09	Condenser Entering Water Temperature (or Outside Air)	705830B-01
S11	Total Unit Amps	
S12	Suction Temperature Circuit #1	705830B-02
S13	Suction Temperature Circuit #2	705830B-01
S14	Liquid Line Temperature Circuit #1	705830B-01
S15	Liquid Line Temperature Circuit #2	705830B-02

Figure 11.

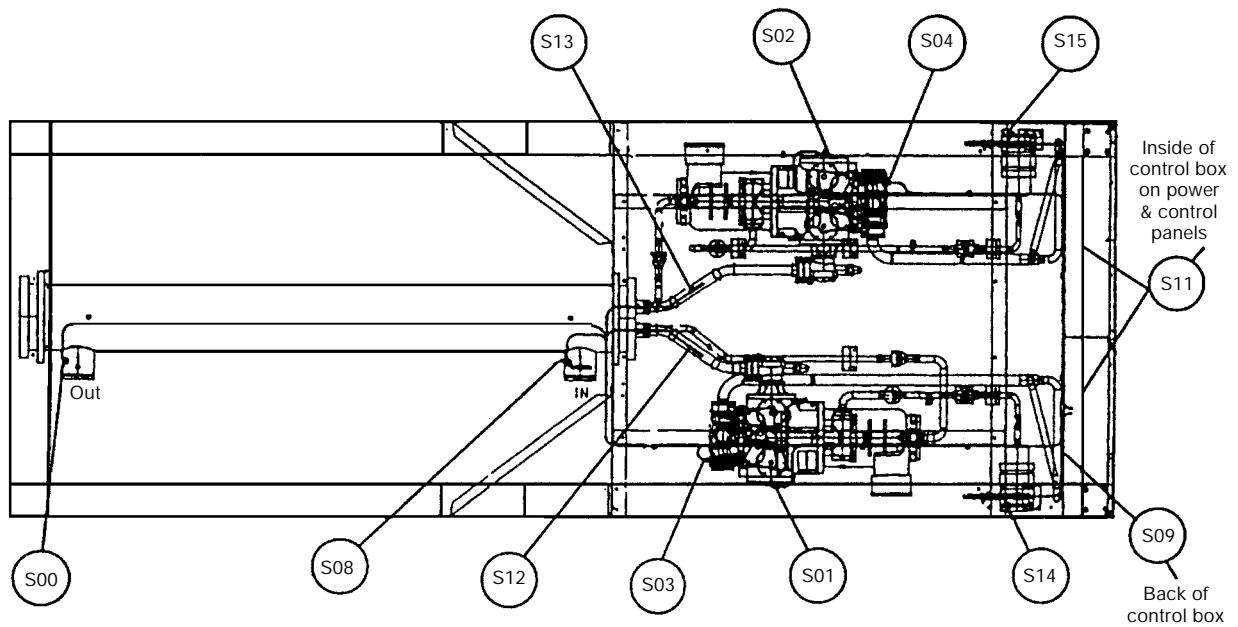

## Analog Inputs

Analog inputs are used to read the various temperature and pressure sensors installed on the chiller as well as any customer supplied 4-20mA reset signals. The controller's

internal regulated 5 VDC and 12 VDC supplies provide the correct operating voltage for the sensors.

*Table 4a. Analog inputs — 2 compressor units*

No.	Description	Sensor Location
S00	Evaporator Leaving Water Temp	Leaving chilled water nozzle
S01	Evap Pressure Transducer, Cir #1	Common cir #1 suction line
S02	Evap Pressure Transducer, Cir #2	Common cir #2 suction line
S03	Cond Pressure Transducer, Cir #1	Compressor #1 discharge cover
S04	Cond Pressure Transducer, Cir #2	Compressor #2 discharge cover
S05	Transducer Power Voltage Ratio	(Internal)
S06	Reset-Evap Water Temperature	External 4-20 mA signal
S07	Demand Limit	External 4-20 mA signal
S08	Entering Evaporator Water Temp	Entering chilled water nozzle
S09	O.A.T. (Ent Cond Water Temp)	Back of the control box
S10	Condenser Leaving Water Temp	Leaving condenser water nozzle
S11	Percent Unit Amps	Signal converter board
S12	Suction Temperature Circuit #1	Well brazed to the cir #1 suction line
S13	Suction Temperature Circuit #2	Well brazed to the cir #2 suction line
S14	Liquid Line Temperature Circuit #1	Well brazed to the cir #1 liquid line
S15	Liquid Line Temperature Circuit #2	Well brazed to the cir #1 liquid line

*Table 4b. Analog inputs — 3 compressor units*

Sensor Number	Description
S00	Evaporator Leaving Water Temperature
S01	Low Pressure Transducer Circuit #1
S02	Low Pressure Transducer Circuit #2
S03	High Pressure Transducer Circuit #1
S04	High Pressure Transducer Circuit #2
S06	Evaporator Water Temperature Reset (Field Supplied)
S07	Demand Limit (Field Supplied)
S08	Evaporator Entering Water Temperature
S09	Outside Air Temperature
S10	Percent Circuit Amps Circuit #1
S11	Percent Circuit Amps Circuit #2
S12	Suction Temperature Circuit #1
S13	Suction Temperature Circuit #2
S14	Liquid Line Temperature Circuit #1
S15	Liquid Line Temperature Circuit #2
S16	Low Pressure Transducer Circuit #3
S17	High Pressure Transducer Circuit #3
S18	Suction Temperature Circuit #3
S19	Liquid Line Temperature Circuit #3
S20	Discharge Temperature Circuit #1
S21	Discharge Temperature Circuit #2
S22	Discharge Temperature Circuit #3
S23	Percent Circuit Amps Circuit #3

*Table 4c. Analog inputs — 4 compressor units*

Sensor Number	Description
S00	Evaporator Leaving Water Temperature
S01	Low Pressure Transducer Circuit #1
S02	Low Pressure Transducer Circuit #2
S03	High Pressure Transducer Circuit #1
S04	High Pressure Transducer Circuit #2
S06	Evaporator Water Temperature Reset (Field Supplied)
S07	Demand Limit (Field Supplied)
S08	Evaporator Entering Water Temperature
S09	Outside Air Temperature
S10	Percent Circuit Amps Circuit #1 & 3
S11	Percent Circuit Amps Circuit #2 & 4
S12	Suction Temperature Circuit #1
S13	Suction Temperature Circuit #2
S14	Liquid Line Temperature Circuit #1
S15	Liquid Line Temperature Circuit #2
S16	Low Pressure Transducer Circuit #3
S17	High Pressure Transducer Circuit #3
S18	Suction Temperature Circuit #3
S19	Liquid Line Temperature Circuit #3
S20	Low Pressure Transducer Circuit #4
S21	High Pressure Transducer Circuit #4
S22	Suction Temperature Circuit #4
S23	Liquid Line Temperature Circuit #4

## Sensor Locations – 3 Screw Compressor Unit

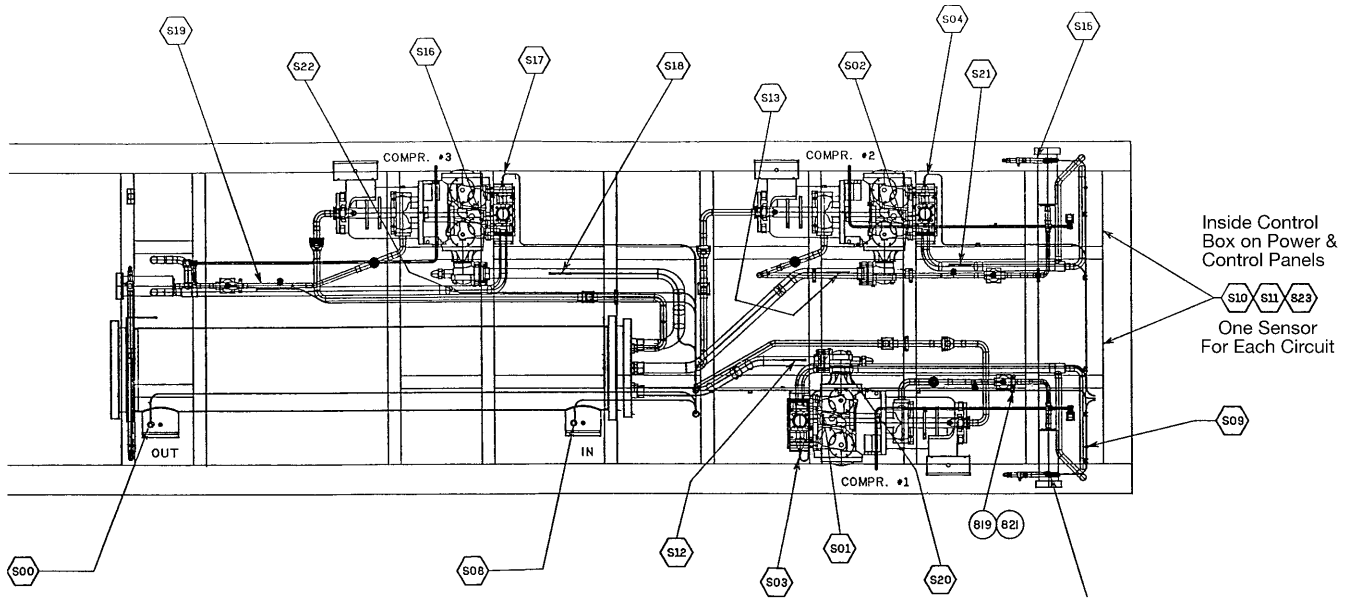

## Sensor Locations – 4 Screw Compressor Unit

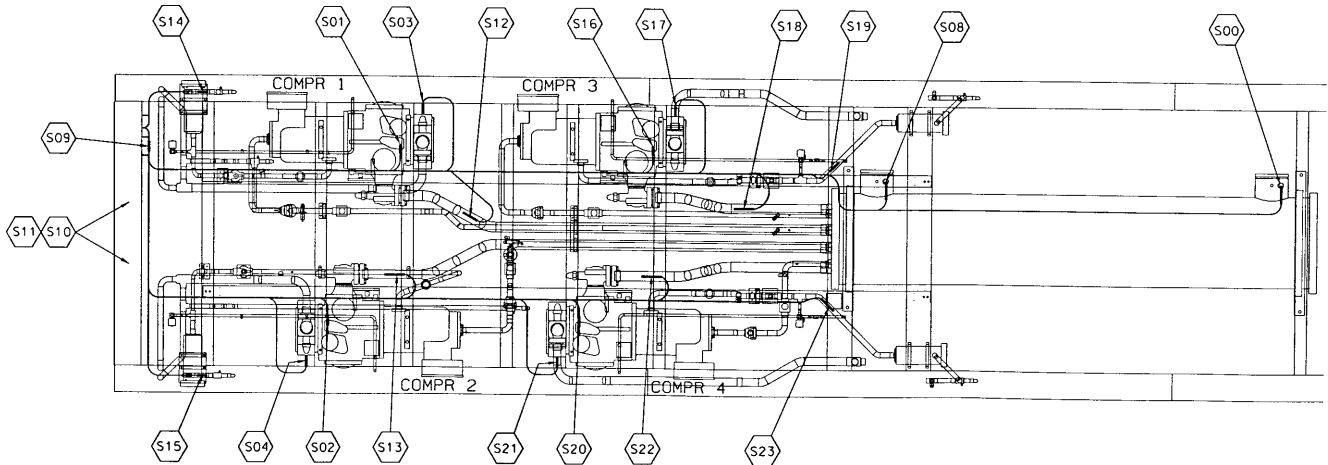

## Digital Inputs

**Note:** All digital inputs are 24 VAC.

At 7.5 VAC to 24 VAC the digital input contacts are considered closed, and the signal level is high.

Below 7.5 VAC, the contacts are considered open, and the signal level is low.

*Table 5a. Digital inputs — 2 compressor unit*

Number	Description	Lo Signal	Hi Signal
0	Mechanical High Pressure Switch, Circuit #1	Alarm	Normal
1	Liquid Presence Switch, Compressor #1	Alarm	Normal
2	Motor Protect, Compressor #1	Alarm	Normal
3	Oil Level Sensor, Compressor #1	Alarm	Normal
4	(Reserved)		
5	System Switch (S1)	Stop	Run
6	Phase Voltage Monitor	Alarm	Normal
7	Pump Down Switch, Circuit #1	Normal	Pumpdown
8	Mechanical High Pressure Switch, Circuit #2	Alarm	Normal
9	Liquid Presence Switch, Compressor #2	Alarm	Normal
10	Motor Protect, Compressor #2	Alarm	Normal
11	Oil Level Sensor, Compressor #2	Alarm	Normal
12	(Reserved)		
13	Unit Remote Stop Switch	Stop	Run
14	Evap Water Flow Switch	Alarm	Normal
15	Pump Down Switch, Circuit #2	Normal	Pumpdown

*Table 5b. Digital inputs — 3 compressor unit*

No.	Description	Led Off	Led On
0	Mechanical High Pressure Switch, Cir #1	Alarm	Normal
1	Liquid Presence Sensor Compr #1	No Liquid	Liquid
2	Motor Prot Compr #1	Alarm	Normal
3	Not Used	—	—
4	Not Used	—	—
5	System On-Off Switch	Off	On
6	Phase Volt Monitor Compr #1	Alarm	Normal
7	PumpDown Switch Compr #1	Normal	Pump DN
8	Mechanical High Pressure Switch Cir #2	Alarm	Normal
9	Liquid Presence Sensor Compr #2	No Liquid	Liquid
10	Motor Prot Compr #2	Alarm	Normal
11	Not Used	—	—
12	Not Used	—	—
13	Remote Start Stop Switch	Stop	Start
14	Evap Water Flow Switch	No Flow	Flow
15	PumpDown Switch Compr #2	Normal	PumpDn
16	Mechanical High Pressure Switch Cir #3	Alarm	Normal
17	Liquid Presence Sensor Compr #3	No Liquid	Liquid
18	Motor Prot Compr #3	Alarm	Normal
19	Not Used	—	—
20	Not Used	—	—
21	Phase Volt Monitor Compr #2	Alarm	Normal
22	Phase Volt Monitor Compr #3	Alarm	Normal
23	PumpDown Switch Compr #3	Alarm	Normal

Table 5c. Digital inputs — 4 compressor unit

No.	Description	Led Off	Led On
0	Mechanical High Pressure Switch, Cir #1	Alarm	Normal
1	Liquid Presence Sensor Compr #1	No Liquid	Liquid
2	Motor Prot Compr #1	Alarm	Normal
3	Not Used	—	—
4	Not Used	—	—
5	System On-Off Switch	Off	On
6	Phase Volt Monitor Compr #1	Alarm	Normal
7	PumpDown Switch Compr #1	Normal	Pump DN
8	Mechanical High Pressure Switch Cir #2	Alarm	Normal
9	Liquid Presence Sensor Compr #2	No Liquid	Liquid
10	Motor Prot Compr #2	Alarm	Normal
11	Not Used	—	—
12	Not Used	—	—
13	Remote Start Stop Switch	Stop	Start
14	Evap Water Flow Switch	No Flow	Flow
15	PumpDown Switch Compr #2	Normal	PumpDn
16	Mechanical High Pressure Switch Cir #3	Alarm	Normal
17	Liquid Presence Sensor Compr #3	No Liquid	Liquid
18	Motor Prot Compr #3	Alarm	Normal
19	Not Used	—	—
20	Not Used	—	—
21	Phase Volt Monitor Multi Point	Alarm	Normal
22	Not Used	—	—
23	PumpDown Switch Compr #3	Normal	PumpDn
0	Mechanical High Pressure Switch Cir #4	Alarm	Normal
1	Liquid Presence Sensor Compr #4	No Liquid	Liquid
2	Motor Prot Compr #4	Alarm	Normal
3	Not Used	—	—
4	Not Used	—	—
5	Not Used	—	—
6	Not Used	—	—
7	PumpDown Switch Compr #4	Normal	PumpDn

## Analog Outputs

Table 6. Analog outputs

No.	Description	Signal Range
0	SpeedTrol, Circuit #1	0-10 VDC
1	SpeedTrol, Circuit #2	0-10 VDC
2	SpeedTrol, Circuit #3	0-10 VDC
3	SpeedTrol, Circuit #4	0-10 VDC



## Digital Outputs

Table 7a. Digital outputs — 2 compressor unit

No.	Description	Off	On
0	Alarm LED and Contact	(Programmable)	(Programmable)
1	Chilled Water Pump	Stop	Run
2	EXV Serial Data 1		
3	EXV Serial Data 2		
4	MCR relay, Compr #1	Stop	Run
5	Top Solenoid, Compr #1	Hold	Load
6	Bottom Right Solenoid, Compr #1	Hold	Load
7	Bottom Left Solenoid, Compr #1	Hold	Load
8	MCR Relay, Compr #2	Stop	Run
9	Top Solenoid, Compr #2	Hold	Load
10	Bottom Right Solenoid, Compr #2	Hold	Unload
11	Bottom Left Solenoid, Compr #2	Hold	Load
12	Condenser Fan #1, Circ #1 (M12)	Off	On
13	Condenser Fan #2, Circ #1 (M13)	Off	On
14	Condenser Fan #3, Circ #1 (M14)	Off	On
15	Condenser Fan #4, Circ #1 (M15)	Off	On
16	Condenser Fan #1, Circ #2 (M22)	Off	On
17	Condenser Fan #2, Circ #2 (M23)	Off	On
18	Condenser Fan #3, Circ #2 (M24)	Off	On
19	Condenser Fan #4, Circ #2 (M25)	Off	On
20	Liquid Solenoid Valve, Cir #1	Close	Open
21	Liquid Solenoid Valve, Cir #2	Close	Open
22	(Spare)		
23	(Spare)		

Table 7b. Digital outputs — 3 compressor unit

Relay	Description
0	Alarm Circuit
1	Chilled Water Pump Relay
2	EXV Control
3	EXV Control
4	Compr #1 Contactor
5	Compr #1 Top Solenoid Valve
6	Compr #1 Bottom Right Solenoid Valve (feed)
7	Compr #1 Bottom Left Solenoid Valve (vent)
8	Compr #2 Contactor
9	Compr #2 Top Solenoid Valve (feed)
10	Compr #2 Bottom Right Solenoid Valve (feed)
11	Compr #2 Bottom Left Solenoid Valve (vent)
12	Condenser Fan Contactor M-12
13	Condenser Fan Contactor M-13
14	Condenser Fan Contactor M-14
15	Condenser Fan Contactor M-15
16	Condenser Fan Contactor M-22
17	Condenser Fan Contactor M-23
18	Condenser Fan Contactor M-24
19	Condenser Fan Contactor M-25
20	Compr #3 Contactor
21	Compr #3 Top Solenoid Valve (feed)
22	Compr #3 Bottom Right Solenoid Valve (feed)
23	Compr #3 Bottom Left Solenoid Valve (vent)
24	Condenser Fan Contactor M-32
25	Condenser Fan Contactor M-33
26	Condenser Fan Contactor M-34
27	Condenser Fan Contactor M-35
28	Hot Gas Bypass - SV5
29	Hot Gas Bypass - SV6

Table 7c. Digital outputs — 4 compressor unit

Relay	Description
0	Alarm Circuit
1	Chilled Water Pump Relay
2	EXV Control
3	EXV Control
4	Compr #1 Contactor
5	Compr #1 Top Solenoid Valve
6	Compr #1 Bottom Right Solenoid Valve (feed)
7	Compr #1 Bottom Left Solenoid Valve (vent)
8	Compr #2 Contactor
9	Compr #2 Top Solenoid Valve (feed)
10	Compr #2 Bottom Right Solenoid Valve (feed)
11	Compr #2 Bottom Left Solenoid Valve (vent)
12	Condenser Fan Contactor M-12
13	Condenser Fan Contactor M-13
14	Condenser Fan Contactor M-14
15	Condenser Fan Contactor M-15
16	Condenser Fan Contactor M-22
17	Condenser Fan Contactor M-23
18	Condenser Fan Contactor M-24
19	Condenser Fan Contactor M-25
20	Compr #3 Contactor
21	Compr #3 Top Solenoid Valve (feed)
22	Compr #3 Bottom Right Solenoid Valve (feed)
23	Compr #3 Bottom Left Solenoid Valve (vent)
24	Condenser Fan Contactor M-32
25	Condenser Fan Contactor M-33
26	Condenser Fan Contactor M-34
27	Condenser Fan Contactor M-35
28	Hot Gas Bypass — SV5
29	Hot Gas Bypass — SV6
30	Not Used
31	Compr #4 Contactor
32	Compr #4 Top Solenoid Valve (feed)
33	Compr #4 Bottom Right Solenoid Valve (feed)
34	Compr #4 Bottom Left Solenoid Valve (vent)
35	Condenser Fan Contactor M-42
36	Condenser Fan Contactor M-42
37	Condenser Fan Contactor M-42
38	Condenser Fan Contactor M-42

# Installation

## Controller Calibration

The control software is installed and tested by the factory prior to shipping therefore no periodic calibration of the controller is required. All control and safety set points will be checked and adjusted if necessary by the McQuayService

## Field Wiring

### Analog sensors and transducers

All sensors and transducers required for normal chiller operation are installed and wired by the factory. Any optional analog signals provided by the installing contractor require twisted, shielded pair wire (Belden #8760 or equal).

### Digital input signals

Remote contacts for all digital inputs such as the chilled water flow switch and the remote start/stop switch must be dry contacts suitable for the 24 VAC control signals produced by the screw chiller control panel.

### Digital outputs

Devices wired to the digital outputs typically be an optional Chilled Water Pump control relay or an Alarm Annunciator. The MicroTech output device is a normally open solid state relay with an on board, replaceable 5 amp fuse. The model 250 controller activates a solid state relay by sending a "trigger" signal to the output board via the attached ribbon cable. The relay responds to the trigger by lowering it's resistance which allows current to flow through its "contacts". When the controller removes the trigger signal, the relay's resistance becomes very high, causing the current flow to stop. The status of all outputs are shown by individual red LEDs for ease of determining output status.

### Interlock wiring

All interlock wiring to field devices such as flow switches and pump starters is provided by the installing contractor. Refer to the Field Wiring Drawing as well as the unit wiring schematics and typical application drawings at the end of this manual for details.

### External alarm circuit

The MicroTech panel can activate an external alarm circuit when an alarm or pre-alarm condition is detected. A 24VAC voltage source is available at field wiring terminal #107 to power an external alarm device such as a bell, light or relay. An alarm annunciator rated for a maximum load of 1.8 Amps at 24VAC is to be provided and wired by the installing contractor. The normal and alarm states for the 24VAC alarm signal are programmable by the operator. Available settings are:

Pre-alarm annunciation: Close-or-Open-or-Blink  
Alarm annunciation: Close-or-Open

start-up technician prior to starting the unit. The MicroTech controller contains default set points which will be appropriate for most common installations.

### Power wiring

115VAC power for the control transformer is derived from the 3-phase power connection provided by the electrical contractor.

A separate disconnect for the cooler heating tape and control circuit transformer may be supplied as options on some installations. Wiring for these circuits is to be provided by the installing contractor and should conform to the National Electrical Code and all applicable local building codes.

### Power supplies

There are several internal power supplies used by the controller and its associated circuitry. The regulated 5 VDC power on terminal #42 is used to support the analog inputs on the ADI Board and should not be used to operate any external devices. An unregulated 12 VDC power supply is available on field wiring terminal #56 and an unregulated 24 VAC supply is provided at terminal #81. Both of these may be used for powering external devices such as low current relays and lights.

### Demand limit and chilled water reset signals

Separate 4-20 milliamp signals for remote chilled water reset and demand limit can be provided by the customer and should be connected to the appropriate terminals on the field wiring strip inside the control cabinet. The optional demand limit and chilled water reset signals are 4 to 20 milliamp DC signals. The resistive load used to condition the milliamp input signals is a 249 ohm resistor factory mounted on the ADI Board.

### Communication ports

Communication port "A" is provided on the MicroTech controller for connection to an IBM compatible computer for local or remote system monitoring (Belden 8762 or equivalent). The network uses the RS232 communication standard with a maximum cable length of 50 feet. All communication network wiring utilizes low voltage shielded twisted pair cable. See the Personal Computer Specification section of this manual for specific hardware requirements.

Communication port "B" is used to link the unit controller into a MicroTech network using the RS-485 communication standard. Refer to the field wiring drawing in this manual for details.

## Modem Kit

An optional modem kit may be installed for remote monitoring of the chiller from an off-site PC running McQuay's Monitor software. The kit comes complete with modem, wiring harness and installation instructions.

Remote monitoring of the MicroTech controller requires a dedicated telephone line supplied by the equipment owner. The McQuay Monitor software package used to establish a remote connection to the modem kit must be purchased separately.

## Unit Sequence of Operation

The following sequence of operation is typical for McQuay ALS air cooled and PFS water cooled chillers. The sequence

### Off Conditions

With power supplied to the unit, 115 VAC power is applied through the control fuse F1 to the compressor crankcase heaters, the compressor motor protector circuits, the primary of the 24V control circuit transformer and optionally, the evaporator heater (HTR5). The 24V transformer provides power to the MicroTech controller and related components. With 24V power applied, the controller will check the position of the front panel System Switch (S1). If the switch is in the "stop" position the chiller will remain off and the display will indicate the operating mode to be OFF:SystemSw. The controller will then check the PumpDown Switches. If any switch is in the "stop" position, that circuit's operating mode will be displayed as OFF:RemoteComm if this operating

### Start-up

If none of the above "Off" conditions are true, the MicroTech controller will initiate a start sequence and energize the chilled water pump output relay. The display will indicate Starting as the operating mode. The chiller will remain in the Waiting For Flow mode until the field installed flow switch

### Waiting for Load

Once flow is established the controller will sample the chilled water temperature and compare it against the Leaving Chilled Water Set point, the Control Band and the Load Delay which have been programmed into the controller's memory. If the leaving chilled water temperature is above the Leaving

### Start Requested

In the Start Requested Mode, the electronic expansion valve is assumed to be fully closed. The MicroTech controller will read the evaporator pressure to ensure at least 4 psi of

### Prepurge

In order to purge the compressor of any liquid refrigerant that may be present, the lead compressor is operated at 50% capacity while the electronic expansion valve is held fully closed. The refrigerant circuit will continue to run in this mode until either the evaporator refrigerant pressure drops

## Telephone line for remote modem access

A voice quality, direct dial telephone line is required if remote access and monitoring of the unit controller is desired. The phone line should be terminated with a standard RJ-11 modular phone plug.

may vary depending on various options which may be installed on the chiller.

mode is in effect. If an alarm condition exists which prevents normal operation of both refrigerant circuits, the chiller will be disabled and the display will indicate OFF:AllCompAlarm.

The MicroTech controller allows the operator to manually set the chiller to an off mode via the keypad. The display indicates this operating mode with the message OFF:ManualMode.

Assuming none of the above "Off" conditions are true, the controller will examine the internal time schedule to determine if the chiller should start. The operating mode will be OFF:TimeClock if the time schedule indicates an "off" time period.

indicates the presence of chilled water flow. If flow is not proven within 30 seconds, the alarm output will be activated and the chiller will continue to wait for proof of chilled water flow. When chilled water flow is re-established, the alarm will be automatically cleared.

Chilled Water Set point plus + the adjustable Control Band plus the Start-up Delta Temperature Set point, the controller will select the refrigerant circuit with the lowest number of starts as the lead circuit and initiate the compressor start sequence.

refrigerant pressure is present. If the evaporator pressure is less than 4 psi the compressor will not be enabled and the display will read "NoStart-LoEvap".

to less than 40 psi or 45 seconds has elapsed. If the evaporator pressure does not drop to 40 psi within the 45 seconds, the compressor will stop and the display will read "Failed Prepurge". The alarm output will be activated.

## Opened EXV

With the evaporator pressure less than 40 psi and the compressor still running, the electronic expansion valve will be driven open to 200 steps. If the evaporator pressure rises above the freeze stat set point, the chiller will advance to

Cool Staging Mode. If the circuit is in Cool Staging Mode and after 20 seconds, the evaporator pressure remains below the freeze state set point but is greater than 2 psi, the controller will transition to Low Ambient Start Mode.

## Low Ambient Start

If the difference between the freeze stat set point and the evaporator refrigerant pressure is greater than 12 psi, the low ambient start timer will be set to 180 seconds. The compressor will continue to run for 180 seconds from the moment the expansion valve is opened in an attempt to build up the evaporator pressure. If the difference between the freeze stat set point and the evaporator refrigerant pressure is greater than 12 psi, the following calculation will be used to set the low ambient start timer:

$$\text{Low Ambient Timer} = 360 - (\text{Pressure Difference} \times 15)$$

If the calculated low ambient timer value is greater than 360, the compressor will be stopped, the alarm output will be activated and the display will indicate "FailLowAmbStart".

## Cool Stage

Circuit capacity at initial start will be 50%. Once the chiller has started, the MicroTech controller will add or subtract cooling capacity to maintain the chilled water set point. The current cooling stage will be displayed on the keypad/display.

Automatic chiller staging may be overridden by selecting "Manual Cooling" as the operating mode and then choosing the desired cooling stage.

## Compressor Control

### Normal Compressor Staging Logic

The Compressor Staging Logic uses an adjustable control band and interstage timers to determine the correct number of cooling stages to activate. A project-ahead temperature

calculation provides stable operation. The total number of cooling stages for each circuit is dependent upon the "number of cooling stages" set point.

## Compressor Staging Sequence

### Four Compressors Available

*Staging Up*

*Staging Down*

Stage	Lead Compressor	Lag 1 Compressor	Lag 2 Compressor	Lag 3 Compressor	Unit Capacity	Lead Compressor	Lag 1 Compressor	Lag 2 Compressor	Lag 3 Compressor	Unit Capacity
1	—	—	—	—	0.0%	25%	0%	0%	0%	6.3%
2	50%	0%	0%	0%	12.5%	50%	0%	0%	0%	12.5%
3	75%	0%	0%	0%	18.8%	75%	0%	0%	0%	18.8%
4	50%	50%	0%	0%	25.0%	50%	50%	0%	0%	25.0%
5	75%	50%	0%	0%	31.3%	75%	50%	0%	0%	31.3%
6	75%	75%	0%	0%	37.5%	50%	50%	50%	0%	37.5%
7	75%	50%	50%	0%	43.8%	75%	50%	50%	0%	43.8%
8	75%	75%	50%	0%	50.0%	50%	50%	50%	50%	50.0%
9	75%	75%	75%	0%	56.3%	75%	50%	50%	50%	56.3%
10	75%	75%	50%	50%	62.5%	75%	75%	50%	50%	62.5%
11	75%	75%	75%	50%	68.8%	75%	75%	75%	50%	68.8%
12	75%	75%	75%	75%	75.0%	75%	75%	75%	75%	75.0%
13	100%	75%	75%	75%	81.3%	100%	75%	75%	75%	81.3%
14	100%	100%	75%	75%	87.5%	100%	100%	75%	75%	87.5%
15	100%	100%	100%	75%	93.8%	100%	100%	100%	75%	93.8%
16	100%	100%	100%	100%	100.0%	100%	100%	100%	100%	100.0%

## Three Compressors Available

*Staging Up*

*Staging Down*

Stage	Lead Compressor	Lag 1 Compressor	Lag 2 Compressor	Lag 3 Compressor	Unit Capacity	Lead Compressor	Lag 1 Compressor	Lag 2 Compressor	Lag 3 Compressor	Unit Capacity
1	—	—	—	—	0.0%	25%	0%	0%	0%	6.3%
2	50%	0%	0%	0%	12.5%	50%	0%	0%	0%	12.5%
3	75%	0%	0%	0%	18.8%	75%	0%	0%	0%	18.8%
4	50%	50%	0%	0%	25.0%	50%	50%	0%	0%	25.0%
5	75%	50%	0%	0%	31.3%	75%	50%	0%	0%	31.3%
6	75%	75%	0%	0%	37.5%	50%	50%	50%	0%	37.5%
7	75%	50%	50%	0%	43.8%	75%	50%	50%	0%	43.8%
8	75%	75%	50%	0%	50.0%	75%	75%	50%	0%	50.0%
9	75%	75%	75%	0%	56.3%	75%	75%	75%	0%	56.3%
10	100%	75%	75%	0%	62.5%	100%	75%	75%	0%	62.5%
11	100%	100%	75%	0%	68.8%	100%	100%	75%	0%	68.8%
12	100%	100%	100%	0%	75.0%	100%	100%	100%	0%	75.0%

## Two Compressors Available

*Staging Up*

*Staging Down*

Stage	Lead Compressor	Lag 1 Compressor	Lag 2 Compressor	Lag 3 Compressor	Unit Capacity	Lead Compressor	Lag 1 Compressor	Lag 2 Compressor	Lag 3 Compressor	Unit Capacity
1	—	—	—	—	0.0%	25%	0%	0%	0%	6.3%
2	50%	0%	0%	0%	12.5%	50%	0%	0%	0%	12.5%
3	75%	0%	0%	0%	18.8%	75%	0%	0%	0%	18.8%
4	50%	50%	0%	0%	25.0%	50%	50%	0%	0%	25.0%
5	75%	50%	0%	0%	31.3%	75%	50%	0%	0%	31.3%
6	75%	75%	0%	0%	37.5%	75%	75%	0%	0%	37.5%
7	100%	75%	0%	0%	43.8%	100%	75%	0%	0%	43.8%
8	100%	100%	0%	0%	50.0%	100%	100%	0%	0%	50.0%

## One Compressor Available

*Staging Up*

*Staging Down*

Stage	Lead Compressor	Lag 1 Compressor	Lag 2 Compressor	Lag 3 Compressor	Unit Capacity	Lead Compressor	Lag 1 Compressor	Lag 2 Compressor	Lag 3 Compressor	Unit Capacity
1	—	—	—	—	0.0%	25%	0%	0%	0%	6.3%
2	50%	0%	0%	0%	12.5%	50%	0%	0%	0%	12.5%
3	75%	0%	0%	0%	18.8%	75%	0%	0%	0%	18.8%
4	100%	0%	0%	0%	25.0%	100%	0%	0%	0%	25.0%

## Project-Ahead Calculation

The Project-Ahead Calculation provides protection against an overshoot condition when the chilled water temperature is outside the control band. During cooling mode, if the Chilled Water Temperature is above the control band and the rate of temperature reduction is so great that in 120 seconds

the chilled water temperature will be below the control band, the controller will stage down. The Project-Ahead Calculation also moderates the controllers response to a rapid increase in leaving water temperature.

## Interstage Timer

The minimum time delay between stage up commands is set by the interstage timer set point (default=210 sec). The

interstage timer for stage down commands is  $\frac{1}{3}$  of the stage up timer.

## Anti-Cycle Timer

Anti-cycle timers are used to protect the compressors from excessive starts and high motor winding temperature. The

anti-cycle timers are 5 minutes stop-to-start and 15 minutes start-to-start.

## Compressor Heater Control

Compressor Heater Control for PFS units is based on the suction line superheat. If the superheat reading drops below

3°F, the heater will be energized. The heater will be de-energized when the superheat rises above 8°F.

# Lead-Lag of Refrigerant Circuits

The following compressor control rules are enforced in the control software.

- The MicroTech controller will never turn on the lag compressor until the lead compressor is at 75% capacity or greater and additional cooling capacity is required.

## Automatic Lead-Lag

The controller provides automatic lead-lag of refrigeration circuits based on compressor operating hours and the number of starts. The circuit with the fewest number of starts will

## Manual Lead-Lag

The operator may override automatic circuit selection by manually selecting the lead circuit via the keypad.

When the set point equals "auto", the lead compressor is selected by the MicroTech controller based upon which

- The MicroTech controller will not turn off the lag compressor until the lead compressor is running at 50% capacity, the lag compressor is running at 25% capacity and a reduction in cooling capacity is required.

be started first. If circuits are operating and a stage down is required, the circuit with the most operating hours will cycle off first.

circuit has the least operating hours. Regardless of the mode selected, if the lead circuit cannot operate due to an alarm condition or if off on cycle timers, the controller will switch to the lag circuit.

# Electronic Expansion Valve

## Overview

McQuay screw compressor chillers are supplied with Sporlan SE-series electronic expansion valves. The MicroTech controller generates valve positioning signals to maintain refrigerant circuit superheat to within 1.5°F of the superheat set point. Valve positioning signals are converted to actuator

step pulses by the EXV board which in turn drive the valve's 3-phase DC stepper motor open or closed as required. A control range of 0 steps (full closed) to 760 steps (full open) is available to provide precise control of the valve position.

## EXV Superheat Control

The electronic expansion valve position will be adjusted to maintain the refrigerant circuit's superheat set point. Superheat set points are based on refrigerant circuit capacity. For circuit capacity of 25% to 50%, the superheat set point will be 8.0°F. For circuit capacity of 75% to 100%, the superheat set point will be 10.0°F.

When the chiller control panel is powered up, the expansion valve will be driven closed 800 steps. This ensures that the valve is fully closed prior to a call for cooling. When all refrigerant circuit safeties are satisfied, the controller will initiate a start sequence. When the start sequence reaches "open solenoid", the expansion valve will be driven open to the First Open set point (default=200 steps). The current

suction line temperature is compared against the Suction Line Temperature set point (evaporator temp plus superheat spt) to calculate superheat error (Err). The current suction line temperature is also compared with the previous reading to calculate delta superheat error (DErr). These two error values are used to determine the magnitude and direction of the expansion valve positioning signal. A new valve positioning signal is calculated every 10 seconds, however, the interval at which these signals are issued to the EXV board is dependent on the magnitude of the required positional change. If no change is required, the interval will be 60 seconds.

## Forced EXV Position Change

With an increase in circuit capacity, the electronic expansion valve position will be opened by a fixed percentage of its current position. This change will not occur if the superheat is less than 4°F below the superheat set point.

With a decrease in circuit capacity, the electronic expansion valve position will be closed by a fixed percentage of its current position.

Table 8a.

When Staging Up		
From	To	Open
25%	50%	65%
50%	75%	50%
75%	100%	25%

Table 8b.

When Staging Down		
From	To	Close
100%	75%	18%
75%	50%	40%
50%	25%	60%

## EXV Evaporator Pressure Control

The electronic expansion valve control will maintain a constant superheat for suction line temperature up to 60°F. For suction line temperatures greater than 61°F, the expansion valve control logic will maintain a constant evaporator temperature to avoid overloading the compressor motor. The

control point will be the Evap Temp set point (default=50°F) and the control method will be the standard MicroTech Step and Wait algorithm. When the suction line temperature drops below 57°F, the MicroTech logic will resume normal superheat control.

## Chilled Water Reset Options

### Chilled Water Reset (Remote 4-20mA)

The controller resets the chilled water set point based on an external 4 to 20mA signal. At 4 mA or less, no reset will occur. At 20mA, the chilled water set point will be reset by an

amount equal to the value stored in the Maximum Reset set point. The reset schedule is linear and may be calculated using Figure 12.

Figure 12.

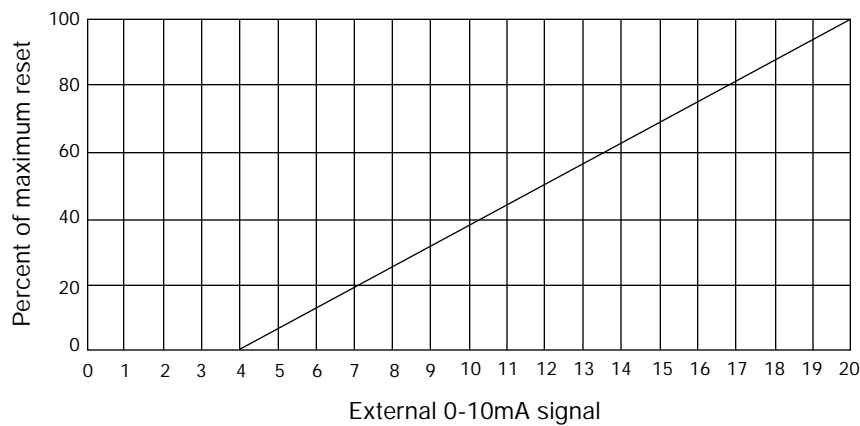

## Ice Mode

The MicroTech controller has dual chilled water set points when ice mode is selected. With an external reset signal of 4mA or less, the chilled water reset will be zero. If the external reset signal is greater than 4mA, maximum reset will be in

effect. For installations requiring operation in ice mode, the following set points should be adjusted to accommodate the reduced system temperature and pressures.

Table 9.

Set Point	Monitors	Default	Ice Mode
FreezeStat	Low Evap Pressure	54 psig	A pressure value equivalent to the leaving solution temperature minus 10°F
FreezeH20	Leaving Solution	36°F	A temperature value equal to the leaving solution temperature minus 4°F
StpPumpDn	Final Pumpdown	34 psig	A pressure value equal to the FreezeStat set point minus 10 psi

## Network Reset

The reset mode can be set to "network" if chilled water reset via communications network is desired. The chiller controller

receives a signal from the network master panel in the range of 0% to 100% of maximum reset.

## Return Water Reset

When return water is selected as the reset mode, the MicroTech controller will adjust the leaving chilled water set point to maintain a constant return water temperature equal to the return water set point. The return water temperature is sampled every 5 minutes and a proportional correction is

made to the leaving chilled water set point. The corrected leaving water set point is never set to a value greater than the return water set point and is never set to a value less than the actual leaving chilled water set point.

## Remote Demand Limit

The controller will limit the total number of stages based on an external 4 to 20mA signal regardless of the amount of cooling actually required. A 4mA or less signal will enable all

stages while a 20mA signal will allow only 1 stage to operate. The effect of the reset signal may be calculated by using Figure 13.

## Network Demand Limit

Unit demand limit via network communication may be selected if desired. The chiller controller receives a demand

limit signal from the network master panel in the range of 0% to 100% with 0 equaling no limit.

## Soft Loading

The soft loading feature limits the number of cooling stages which may be energized by the controller to prevent unnecessary electrical demand and possible over-shoot of the desired leaving chilled water temperature. Soft loading is typically used during morning start-up. When the controller

enters the "Cool Staging" mode of operation, the controller will start a count down timer to indicate how long the unit has been in the cool staging mode. The maximum number of cooling stages will be limited to the soft load set point until the soft load count down timer equals zero.

## Max Pull Down

The controller can limit the rate at which the chilled water loop temperature is reduced. Whenever the rate of tempera-

ture decrease exceeds the maximum pull down set point, no additional cooling stages will be activated.

## Condenser Fan Control

### Condenser Fan Staging

The first condenser fan staging will be started in conjunction with the first compressor to provide initial head pressure control. The MicroTech controller continuously monitors the lift pressure referenced to several head pressure control set points and will adjust the number of operating condenser

fans as required to maintain proper head pressure.

For PFS water cooled units, the condenser pump will be started in conjunction with the first compressor to provide head pressure control.

### Head Pressure Control (Air Cooled Units Only)

For each circuit, the first stage of condenser fans will be wired in parallel with the compressor output so that they are energized with the compressor. For chillers with optional SpeedTrol, the first condenser fan stage will receive a control signal from the AOX board which in turn modulates the Johnson Controls S66DC-1 to provide variable speed fan operation. Each circuit has 3 additional digital outputs available for refrigerant head pressure control. Each output will energize an additional bank of condenser fans with each bank consisting of 1 or 2 fans depending on the size of the unit. Each output energizes additional heat rejection due to increased air flow across the air cooled condenser regard-

less of the number of fans. If the outdoor ambient temperature is greater than 60°F when the unit is started, one additional condenser fan stage will be energized. If the outdoor ambient temperature is greater than 80°F, two additional fan stages will be energized.

ALS unit EERs are maximized by not allowing the last condenser fan stage to operate when the unit capacity is 25% and the condenser pressure is below 200 psi. The last fan stage will operate if the condenser pressure is above 220 psi at 25% unit capacity.



## Lift Pressure Calculation

The minimum acceptable lift pressure is determined by the expansion valve. At low tonnage capacities, a minimum lift pressure of approximately 60 psid must be maintained. At higher tonnage capacities, a higher lift pressure must be maintained to provide proper refrigerant flow through the expansion valve. Refer to the following table for the lift pressure values maintained at various unit capacities. Individual head pressure set points are provided at 25%, 50%, and 100% circuit capacity to optimize chiller operation. For operation at 75% capacity and greater with outdoor air temperatures less than 60°F, the minimum lift will automatically be reset downward. The maximum available reset at

100% capacity is 40 psid while the maximum reset at 75% capacity is 20 psid.

Table 10.

Capacity	Set Point	Adjustment Range
25%	60 psig	60-100
50%	70 psig	70-100
75%	105 psig	Fixed
100%	140 psig	100-140

Figure 13.

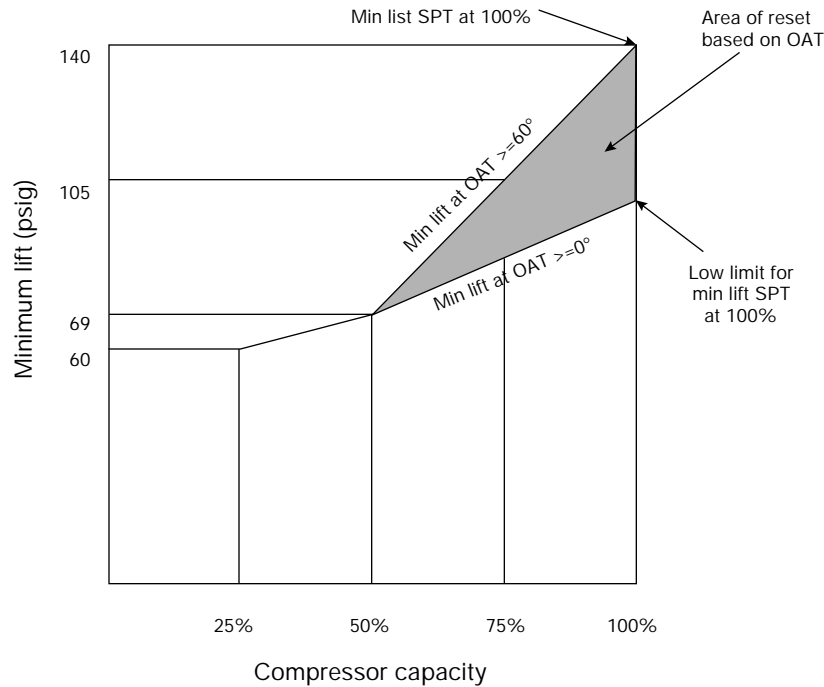

## Lift Pressure Dead Band

The MicroTech controller establishes a dead band above the minimum lift pressure that varies with circuit capacity. If the lift pressure is within the dead band, no fan staging will occur.

Condenser fan staging will occur as follows for lift pressures above or below the dead band.

Table 11a.

Deadband Table - No SpeedTrol							
Unit Capacity	Stage 0	Stage 1	Stage 2	Stage 3	Stage 4	Stage 5	Stage 6
100%	120	100	60	40	30	25	20
75%	120	70	50	30	25	20	20
50%	60	50	30	20	15	15	15
25%	50	30	20	10	10	10	10

Table 11b.

Deadband Table - With SpeedTrol							
Unit Capacity	Stage 0	Stage 1	Stage 2	Stage 3	Stage 4	Stage 5	Stage 6
100%	40	40	40	40	30	25	20
75%	40	40	40	30	25	20	20
50%	70	30	30	20	15	15	15
25%	80	30	20	10	10	10	10

## Condenser Fan Stage Up

Every four seconds, the controller records the difference between the maximum condenser pressure (as defined by the minimum lift plus the dead band) and the actual condenser refrigerant pressure. This value is added to the previously recorded values and when the accumulated total

is equal to or greater than the stage up set point, the controller starts an additional fan stage. The accumulated total is set to zero whenever a fan stage change occurs or the condenser pressure falls inside the dead band. Fan stages 5 or 6 will not be enabled unless the circuit capacity is greater than 50%.

## High Pressure Stage Up

The controller logic will bring on multiple condenser fan

stages if a rapid rise in pressure is detected.

## Condenser Fan Stage Down

Every four seconds, the controller records the difference between the minimum condenser pressure and the actual condenser refrigerant pressure. This value is added to the previously recorded values and when the accumulated total is equal to or greater than the stage down set point, the

controller decrements a fan stage. The accumulated total is set to zero whenever a fan stage change occurs or the condenser pressure rises inside the dead band. Fan stages 5 or 6 will automatically be disabled whenever the circuit capacity falls to 50% or less.

## SpeedTrol Logic

When the SpeedTrol option is installed, the MicroTech controller will generate an analog signal via the AOX board to directly control the S66DC-1 variable speed fan motor control. The control signal is proportional to the condenser pressure's relative position within the lift pressure dead band. Minimum and maximum fan speed is defined by the

minimum and maximum lift pressure set points so that when the condenser pressure is below the dead band, the fan speed will be set to 0% and when the condenser pressure is above the dead band, the fan motor speed will be set to 100%.

Figure 14.

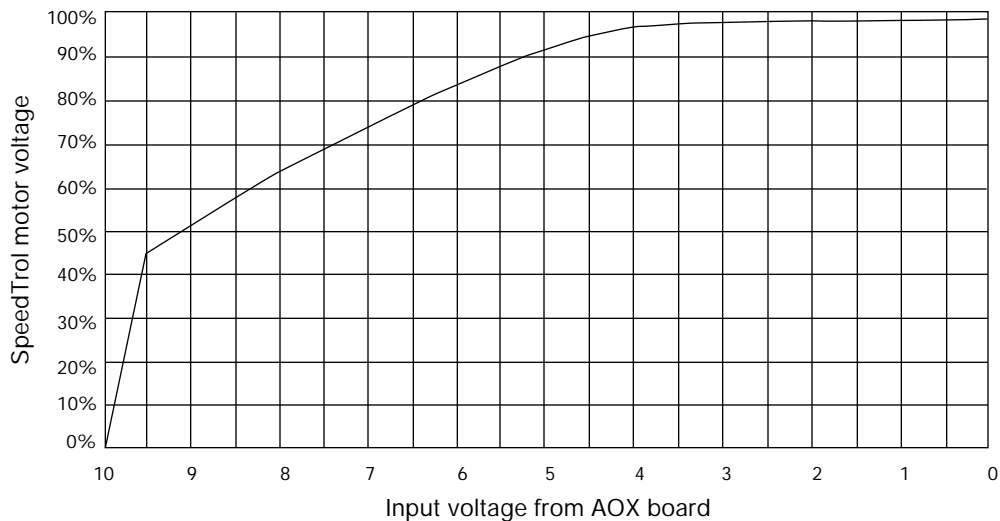

## Pumpdown

### Automatic Pumpdown

As the system chilled water requirements diminish, the compressors will be unloaded. As the system load continues to drop, the electronic expansion valve will be driven to 0 steps, (closed) and the refrigerant circuit will go through a PumpDown sequence. As the evaporator pressure falls below the StopPumpDownPres set point while pumping down,

the compressors and condenser fans will stop. If the evaporator pressure is greater than the StopPumpDownPres set point after 180 seconds have elapsed, the compressor will stop and the display will read "Can't Pump Down". The alarm output will be activated.

## Manual Pumpdown

When the compressor is running and the circuit pumpdown switch is moved from the Auto position to the Stop position, the circuit will pumpdown and stop when the evaporator pressure falls below the "StopPumpdownPressure" set point.

When the compressor is not running and the circuit pumpdown switch is moved from the Auto position to the Stop position, the controller will initiate a pumpdown only if the evaporator pressure is above the "Begin Pumpdown Pressure" set point. The compressor will stop when the

## Service Pumpdown

The normal pumpdown sequence will stop when the evaporator pressure equals the Stop Pumpdown set point pressure. A control set point called FullPumpDown has been provided which will allow an extended pumpdown for service purposes.

The default value for the FullPumpDown set point is "No". By changing this setting to "Yes", the circuit will attempt to pump down to 2 psi during the next pumpdown cycle. If 2 psi

evaporator pressure falls below the "Stop Pumpdown Pressure" set point.

An additional pumpdown sequence can be performed by moving the pumpdown switch to the Auto position for approximately 3 seconds and then back to the Stop position. If the evaporator pressure is above the "Begin Pumpdown Pressure" set point, the controller will initiate a pumpdown sequence and the compressor will stop when the evaporator pressure falls below the "StopPumpdownPressure" set point.

cannot be obtained, the compressor will stop after 300 seconds have elapsed. The set point will be set to "No" automatically at the end of the cycle.

**Note:** All pumpdown modes are disabled if the system switch (S1) is in the Stop position.

**Note:** Compressor capacity during a pumpdown sequence will be 50%.

## Safety Systems

### System Alarms

Alarm conditions which are common to both refrigerant circuits are considered to be system alarms. On a system alarm, the MicroTech controller will shut down both compressors and energize the alarm output.

#### Loss of Chw flow

On a loss of chilled water flow for three consecutive seconds while the chiller is in cooling mode, all operating refrigerant circuits will pump down and stop. The display will read "Loss of ChW Flow". When chilled water flow resumes, the chiller will initiate a normal start sequence.

#### Bad phase/voltage

The factory mounted voltage protection device will signal the MicroTech controller if the incoming 3-phase power is not within acceptable limits. The controller will immediately shut the chiller down. When the voltage protection device indi-

cates that the incoming power is back within acceptable limits, normal chiller operation will resume.

#### No 5VDC @AI#5

The controller continuously monitors the output of both internal 5VDC power supplies and calculates their ratio. If the microprocessor is not receiving an acceptable volts ratio signal, the unit will be shut down. The voltage present at analog input #5 must be between 4.15 and 4.94 VDC.

#### Chilled water freeze protect

If the leaving chilled water temperature falls below the adjustable freeze H2O set point, the unit will be shut down.

#### Bad leaving chilled water sensor

If the MicroTech controller detects an open or shorted leaving water sensor, the chiller will be shut down.

### Circuit Alarms

Alarm conditions which are unique to each refrigerant circuit are considered to be circuit alarms. On a circuit alarm, the MicroTech controller will shut down the affected circuit's compressor and energize the alarm output.

#### Mechanical high pressure

Closure of the HP1 or HP2 relay contacts indicates an abnormally high compressor discharge pressure. The latching mechanical high pressure switch must be reset before the MicroTech alarm can be cleared.

The mechanical high pressure switches should be set to trip at the following pressures.

ALS Units . . . 400 psi  
PFS Units . . . 380 psi

#### High condenser pressure

If the condenser pressure as sensed by the pressure transducer exceeds the high condenser pressure set point (default=380 psi), the circuit will be shut down until the alarm is manually reset.

#### High condenser pressure stage down

If the condenser pressure rises to within 20 psi of the condenser high pressure set point, the controller will automatically reduce the refrigerant circuit's capacity by one cooling stage every 10 seconds until the condenser pressure falls below the 20 psi threshold. (HiCondPre-20)

If two high pressure stage downs occur within a 60 minute period, the normal interstage timer will be extended to 15 minutes to inhibit any stage up requests. Normal chiller staging will resume once this 15 minute timer expires.

### High condenser pressure stage hold

If the condenser pressure rises to within 30 psi of the condenser high pressure set point, the controller will hold the circuit at its current capacity.

Normal chiller operation will resume once the condenser pressure drops below the high pressure stage hold threshold.

### No liquid start

If liquid refrigerant is not present at the compressor's injection port within 20 seconds of a start request, the circuit will be shut down and the fault will be recorded. The circuit will automatically attempt to re-start after the cycle timer expires. If a no liquid start is recorded during the second start attempt, the circuit is shut down and the alarm output is energized. No additional starts will be attempted until the alarm is manually cleared.

### No liquid run

The refrigerant circuit will be shut down if liquid injection is lost during normal chiller operation. One automatic re-start will occur after the cycle timer expires. If another no liquid run fault is recorded after the re-start, the circuit will be shut down and the alarm output will be energized.

### Can't start-low evaporator pressure

If the evaporator pressure is less than 4 psi when a compressor start is requested, the start will be aborted.

### Low evaporator pressure

A low evaporator pressure alarm will occur if the refrigerant pressure drops below the low pressure cutout set point (default=2 psi).

### Freeze protect stage down and freeze stat protect

The controller records the amount of time the evaporator refrigerant pressure is below the freeze stat set point (default=54 psi). The magnitude of the error will determine the time delay before a circuit stage down or alarm shutdown occurs.

Table 12.

Error	S.D. Delay	Alarm Delay
2 psi	100 seconds	160*
4 psi	87 seconds	140
6 psi	74 seconds	100
8 psi	60 seconds	100
10 psi	48 seconds	80
12 psi	35 seconds	40
14 psi	22 seconds	40
17 psi	0 seconds	0

Once the time delay is satisfied, the controller will stage down once every 20 seconds. If the controller stages down to cooling stage 0, the circuit will pump down and the compressor will stop. The circuit will restart automatically when the anti cycle timer expires.

### Failed pre-purge

The start sequence will be aborted if the compressor cannot pre-purge the evaporator.

### Failed EXV or low refrigerant charge

If the pre-purge is successful but the evaporator pressure does not rise after the electronic expansion valve is commanded to open, the circuit will be shut down.

### Failed low ambient start

The circuit will be shut down if the controller records an unsuccessful low ambient start.

### Can't pump down

A pumpdown elapse timer (180 seconds) is started whenever the controller initiates a pumpdown sequence. If the circuit is still attempting to pump down when the timer expires, the compressor is stopped and the alarm output is activated. The display reads "Can't Pump Down".

### Bad evaporator pressure sensor

A shorted or open evaporator pressure sensor will shut down the refrigerant circuit and activate the alarm output.

### Bad condenser pressure sensor

A shorted or open condenser pressure sensor will shut down the refrigerant circuit and activate the alarm output.

### Wait flooded

Suction superheat is less than 3°F and compressor will not start.

### Wail flooded xxx

Liquid presence sensor detected liquid in the compressor. xxx indicates time in minutes before unit will start after liquid clears from the compressor.

# MicroTech Controller Test Procedures

## ⚠ CAUTION

Service test mode should only be used by McQuayService personnel or other factory trained technicians. The following test procedures will disable all normal chiller controls and safeties. All compressors **MUST** be disabled by opening circuit breakers or by disconnecting the 3-phase power before beginning tests. Failure to do so can result in severe compressor damage.

## Service Test (Digital Outputs)

Select control mode, menu 13 and set the chiller's control mode to Service Testing. Select menu 22 and with the Prev or Next item keys, select the digital output you wish to test. Enter the service password when prompted by the display. Pressing the Inc key will turn the selected output on, pressing the Decr key will turn it off. All outputs except 1, 2, 4 and 8 will remain in their last commanded state until the Service Testing

mode is turned off. Manually operating outputs 1 and 2 will drive the electronic expansion valve open or closed. Compressor MCR outputs 4 and 8 will only remain in the on state for 15 seconds.

Exit the Service Testing mode by selecting the desired chiller operating mode from menu 13.

## Service test (Digital Inputs)

Select control mode, menu 13 and set the chiller's control mode to Service Testing. Select menu 22 and with the Prev or Next item keys, select test #16, DH1. The current state of the first 8 digital inputs (0-7) will be represented on the keypad/display as a row of ones or zeroes where 1 equals "on" and 0 equals "off". By manipulating field wired devices (system switch, motor project, etc.) and watching the keypad/display, the status of the first eight digital inputs can be verified.

Press the Next item key to select test #17, DH2. The current state of the second 8 digital inputs (8-15) will be represented on the keypad/display as a row of ones or zeros where 1 equals "on" and 0 equals "off". By manipulating field wired devices (flow switch, remote stop switch, etc.) and watching the keypad/display, the status of the second eight digital inputs can be verified.

Exit the Service Testing mode by selecting the desired chiller operating mode from menu 13.

# Keypad/Display

## Overview

The information stored in the MicroTech controller can be accessed through the keypad using a tree-like structure. This tree structure is divided into Categories, Menus and Menu Items. There are three categories which make up the

tree structure: STATUS, CONTROL, and ALARM. Each category is divided into Menus and each menu into Menu Items. The three categories are described below.

## Status Category

Menus and menu items in this category provide information on the MicroTech operating conditions and the chiller operating conditions. The entries under each menu item in this

category provide information only and are not changeable through the MicroTech keypad.

## Control Category

Menus and menu items in this category provide for the input of all the unit control parameters.

These include cooling control, compressor control and

condenser fan control parameters as well as time schedules and alarm limits. The entries under these menu items are changeable through the MicroTech keypad.

## Alarm Category

Menus and menu items in this category provide information

## Display Format

The information stored in the MicroTech controller tree structure can be viewed (one menu and menu character LCD display). The current MENU is shown on the top line and the current MENU ITEM is shown on the bottom line of the display. The operator can select either English or metric engineering units. Once the desired engineering units have been selected, momentarily remove and restore power to the MicroTech controller to complete the change.

regarding current and previous alarm conditions.

### English Units:

Temperature =	°F	(Fahrenheit)
Pressure =	Psi	(Pound per sq. inch)
	Psig	
	Psid	

### Metric Units:

Temperature =	°C	(Centigrade)
Pressure =	Kpa	(Kilo Pascals)
	Kpag	
	Kpda	

## MicroTech Component Test Procedures & ALS Units

### Status LED diagnostics

The MCB status LED indications can aid in controller diagnostics. If the status LEDs do not operate normally as described in the "Component Data" section of this handout (see Tables 1 & 2), there is a problem with the MCB. Following are troubleshooting procedures for the various symptoms.

### Red LED remains on

If the red LED remains on after the 5-second self-test period,

it is likely that the MCB is defective. However, this can also occur in some instances if there is a power supply problem. Refer to "Troubleshooting Power Problems" below.

### Red and green LEDs off

If the red and green LEDs do not turn on after power is applied to the controller, there is likely a defective component or a problem in the controller's power distribution circuits. Refer to "Troubleshooting Power Problems" below.

## Troubleshooting Power Problems

The MCB status receives 18 Vac, center-tapped power from a transformer. It then distributes both 5 Vdc and 13 Vdc power to various MicroTech components. A problem that exists in any of these components can affect the MCB and thus the entire control system. Power problems can be caused by an external short, which can blow a fuse, or a defective component, which can either blow a fuse or create an excessive load on the power supply. An excessive load can lower the power supply voltages to unacceptable levels. Use the following procedure to isolate the problem. **Note:** This procedure may require two or three spare MCB fuses.

1. Verify that circuit breaker CB1 is closed.
2. Remove the MCB Power In connector and check for 9 Vac between the terminals on the plug corresponding to terminals 2 and 3 on the board (Figure 2). Then check for 9 Vac between the terminals on the plug corresponding to terminals 1 and 3 on the board. (Readings of 9-12 Vac are acceptable.)
  - If 9 Vac is present between both sets of terminals, go to step 3.
  - If 9 Vac is not present between both sets of terminals, check both transformers and all wiring between the 115 Vac source and the Power In plug.
3. Remove power from the controller by opening circuit breaker CB1. Check the MCB power supply input fuses (F1 and F2) with an ohmmeter. See Figure 3. A good fuse will have negligible resistance through it (less than 2 ohms).
  - If either or both fuses are blown, replace them. Go to step 4.
  - If the fuses are intact, the MCB is defective.

4. Reconnect the Power In connector and **disconnect all other connectors** on the MCB. Cycle power to the controller (close and then open CB1) and check the power fuses.
  - If both fuses are intact, go to step 5.
5. If either fuse blows, the MCB is defective. Reconnect the keypad/display ribbon cable (if equipped with keypad/display door). Cycle power to the controller and check the power fuses.
  - If both fuses are intact, go to step 6.
  - If either fuse blows, check the keypad/display and the connecting ribbon cable for shorts. Either one may be defective.
6. Reconnect the analog input ribbon cable. Cycle power to the controller and check the power fuses.
  - If both fuses are intact, go to step 7.
  - If either fuse blows, check the ADI board, the connecting ribbon cable, and the field wiring for shorts. Any of these may be defective. Try repeating this step after removing or swapping the ADI board.
7. Reconnect the digital input ribbon cable. Cycle power to the controller and check the power fuses.
  - If both fuses are intact, go to step 8.
  - If either fuse blows, check the ADI board, the connecting ribbon cable, and the field wiring for shorts. Any of these may be defective.
8. Reconnect the digital output ribbon cable to the MCB. Cycle power to the controller and check the power fuses.
  - If both fuses are intact, go to step 9.
  - If either fuse blows, check Output Board and the connecting ribbon cable. Either of these may be defective.

9. If there are any AOX-4 boards, reconnect the expansion bus ribbon cable to the MCB; otherwise, go to step 10. Cycle power to the controller and check the power fuses.
  - If both fuses are intact, go to step 10.
  - If either fuse blows, check the analog output expansion modules (if any), the connecting ribbon cables, and the field wiring for shorts. Any of these may be defective.
10. With circuit breaker CB1 open, measure the resistance between field terminals "DC-GRD" and "5 Vdc." It should be greater than 20 ohms.
  - If the resistance is greater than 20 ohms, go to step 11 if the controller is equipped with at least one AOX-4 board or a modem. Otherwise, the problem is indeterminate. Obtain factory service.
  - If the resistance is less than 20 ohms, it is likely that the keypad/display, the Output Board, or an external (field supplied) load is excessively loading the MCB's 5 Vdc power supply. Isolate the problem by taking resistance measurements on each of these devices with the wiring disconnected. The resistance across the power input terminals on the keypad/display (G and 5V) should be close to infinite. The resistance across the power input terminals on the Output Board (+ and -) should not be less than 3000 ohms. If the component resistances are proper, check the resistance of the field supplied loads (if any) and check the wiring and connections throughout the 5 Vdc power supply circuit.
11. Disconnect the connector plugs from the modem and the power plug from all AOX-4 boards (as applicable). With circuit breaker CB1 open, measure the resistance between field terminals "DC-GRD" and "13 Vdc." It should be infinite.
  - If the resistance is infinite, go to step 12.
  - If the resistance is not infinite, a short exists somewhere in the 13 Vdc power supply wiring.
12. Reconnect the Aux/Out connector plug to the MCB. If there's a modem, reconnect its AMP plug to port A. With

circuit breaker CB1 open, measure the resistance between field terminals "DC-GRD" and "13 Vdc." It should steadily rise to a value greater than 5000 ohms (within approximately 30 seconds).

If the resistance rises above 5000 ohms, go to step 13.

If the resistance does not rise above 5000 ohms, the MCB is defective.

13. one at a time, reconnect the modem and each AOX-4 board (as applicable). Each time a component is reconnected, measure the resistance between field terminals "DC-GRD" and "13 Vdc." It should steadily rise to a value greater than 5000 ohms.

If the resistance rises above 5000 ohms, repeat this step until the modem and all AOX-4 boards (as applicable) have been checked out. If the problem persists, it is indeterminate. Obtain factory service.

If the resistance does not rise above 5000 ohms, the modem or the AOX-4 board just connected is defective. (With the power plug disconnected, the resistance across an AOX-4 board's "DC" and "G" terminals should not be less than 3 million ohms.)

*Figure 15. MCB power supply terminals*

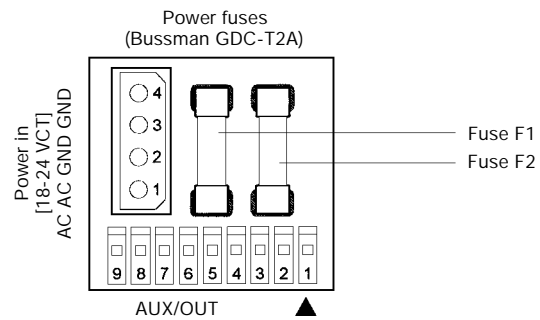

## Troubleshooting Communications Problems

If a communications problem occurs, check the following items:

- Check the port B voltages
- Check the port B fuses
- Check the network integrity
- Check the network addressing

## Troubleshooting the Keypad/Display Interface

The Keypad/Display Interface is connected to the MCB via a ribbon cable and discrete wiring for the back light. The MCB provides operating voltages, control signal outputs for the display, and input conditioning for the keypad inputs.

### Display is hard to read

The clarity of the LCD display can be affected by ambient temperature. Typically, less contrast will result with cooler temperatures. If the display is difficult to read, adjust the contrast trim pot, which is located on the back of the keypad/display assembly.

### Back light not lit

The Keypad/Display Interfaces supplied with the MicroTech control panel is equipped with a back light. If the light does not come on, check for 5 Vdc at terminal 9 on the IDC connector on the KDI and for 5 Vdc on the field wiring terminal strip.

Check for 5 Vdc on the IDC connector on the MCB aux/

The best way to accomplish these checks is to perform the start-up procedures as specified in the "Network Commissioning" section of the appropriate IM manual. If these procedures have performed and the problem persists, obtain factory service.

out. To check for the 5 Vdc on the IDC connector, pull back the plug about one-eighth of an inch and place the test leads against the exposed pins. If there is no voltage the MCB is probably defective.

### Display is blank or garbled

If the MCB appears to be functioning properly and the display is completely blank or garbled, perform the following procedure:

1. Try cycling power to the controller by opening and then closing circuit breaker CB1.
2. Try adjusting the contrast trim pot, which is located on the back of the keypad/display assembly. If the contrast trim pot has no effect, it is likely that either the keypad/display or its ribbon cable is defective.
3. After removing power from the controller, check the ribbon cable and connections between the keypad/display and the MCB. Look for bent pins. Restore power after reconnecting the ribbon cable.

4. Try swapping a known good ribbon cable and keypad/display. Swap these components separately to isolate the problem. Remove power from the controller before dis-

## Troubleshooting Analog Inputs

An analog input, such as a temperature sensor, is connected to the Analog Input terminal strip on the ADI board. The analog input is then conditioned by the ADI board. The conditioned input is transferred to the MCB via a ribbon cable.

### Analog input not read by the MCB

If the MCB appears to be functioning properly and the analog input is not being read by the MCB, perform the following procedure:

1. Try cycling power to the controller by opening and then

## Troubleshooting Digital Inputs

A digital input device is connected to the Digital Input terminal strip on the Input Conditioning Module Terminal Board. 24 Vac, supplied by the CSC, is sent to the digital input device via a supply wire. When a contact in the digital device makes, a return signal is sent back to the Digital Input terminal strip. The signal is then conditioned by the Input Conditioning Module (ICM). The conditioned digital input is then sent to the MCB via a ribbon cable.

### Digital input not read by the MCB

If the MCB appears to be functioning properly and the digital input is not being read by the MCB, perform the following procedure:

## Troubleshooting Analog Outputs

Variable voltage or current control signals are sent to analog outputs by the MCB through the Analog Output Expansion Module (AOX-4) (This can be on the ALS units as the optional fan speed control). The MCB sends a voltage or current signal to the AOX-4 via a ribbon cable. Jumpers on the AOX-4 determine what type of output will be sent to the analog output device. The analog output signals are sent from the AOX-4 by connecting a two-pin Phoenix connector to the Analog Output Ports on the AOX-4.

### Analog output device is not operating correctly

If the MCB appears to be functioning properly and the analog output device is not operating correctly, perform the following procedure:

1. Try cycling power to the controller by opening and then closing circuit breaker CB1.
2. Check the ribbon cable(s), power wiring from the transformer to the AOX-4, field wiring connections from the

connecting the suspect component, and restore power after connecting the replacement component. If the problem persists, it is likely that the MCB is defective.

closing circuit breaker CB1.

2. Check the ribbon cable, power wiring connector, and the field wiring connections from the analog input device. Look for bent pins, cable on backwards, or miswires. Restore power after reconnecting all cables and wires.
3. If the problem persists, try swapping a known good ribbon cable, an ADI board, or analog input device. Swap these components separately to isolate the problem. Remove power from the controller before disconnecting the suspect component, and restore power after connecting the replacement component. If the problem persists, it is likely that the MCB is defective.

1. Try cycling power to the controller by opening and then closing circuit breaker CB1.
2. Check the ribbon cable, power wiring connector, and the field wiring connections from the digital input device. Look for bent pins, cable on backwards, or miswires. Restore power after reconnecting all cables and wires.
3. If the problem persists, try swapping a known good ribbon cable, an ADI board, or a digital input device. Swap these components separately to isolate the problem. Remove power from the controller before disconnecting the suspect component, and restore power after connecting the replacement component. If the problem persists, it is likely that the MCB is defective.

AOX-4 to the analog output device, and the power wiring from the external power supply to the output device. Look for bent pins, cable on backwards, or miswires. Restore power after reconnecting all cables and wires.

**Note:** If the analog output signal supplied by the MCB is a voltage signal (0-5, 0-10 Vdc), the external power supply ground must be grounded to the MCB chassis ground.

3. If the problem persists, try swapping a known good AOX-4, ribbon cable(s), analog output device, or external power supply. Swap these components separately to isolate the problem. Remove power from the controller and analog output device before disconnecting the suspect component, and restore power after connecting the replacement component. If the problem persists, it is likely that the MCB is defective.



## Troubleshooting Output Boards

Each output on the Output Board consists of a solid-state relay, a LED, 5-amp fuse, and an MOV (metal oxide varistor).

Normally, when the MCB commands an output to energize, the solid-state relay contacts will close and the LED will glow. The contacts of each solid-state relay are in series with a 5-amp fuse. These fuses resemble small resistors and are located on the board adjacent to the relays they serve. The fuses are pressed into place. They can be removed with a needle nose pliers. The MOV, which is located on the underside of the output board, protects the solid-state relay from high transient voltages. MOVs are part of the output board and cannot be replaced.

Following are troubleshooting procedures for various symptoms of output board problems.

**Note:** It should be possible to determine whether a solid-state relay is defective by using these procedures. However, if you need more information on troubleshooting them, refer to "Troubleshooting Solid-State relays" below.

Figure 16. Output board relay socket

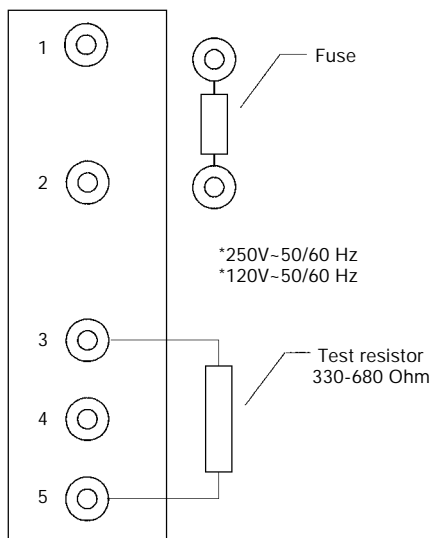

### ⚠ WARNING

**Electric shock hazard.  
Can cause severe injury or death.**

Even when power to the panel is off, solid-state relay socket terminals 1 and 2 on the output board could be connected to high voltage (see Figure 5). Avoid them.

### One LED out

If one of the Output Board LEDs fails to illuminate when the MCB is commanding the associated output to energize, perform the following procedure:

1. Remove power from the controller by opening CB1. Swap the suspect relay with a known good relay. Try to choose a relay that will not affect unit operation. Restore power by closing CB1.
  - If the LED does not light, go to step 2.
  - If the LED lights, the suspect relay is defective.
2. Remove power from the controller. Check the ribbon cable and connections between the OB and the MCB. Look for bent pins.
  - If the cable and connections are intact, go to step 3.
3. Remove the relay from the suspect socket. Install a 330-680 ohm resistor between terminals 3 and 5 as shown in

Figure 5. Restore power by placing CB1 to the ON position. The LED should light regardless of the controller's command.

If the output LED illuminates, it is likely that the MCB is defective.

If the output LED does not illuminate, the output board is defective.

### All LEDs out

If the MCB is commanding at least two outputs to energize and none of the Output Board LEDs are lit, perform the following procedure:

1. Verify that 5 Vdc is present at the Output Board's power terminals.
  - If 5 Vdc is not present, go to step 2.
  - If 5 Vdc is present, check the ribbon cable and connections between the output board and MCB. Look for bent pins. If the cable and connections are intact, the Output Board or the MCB is defective.
2. Remove power from the controller by placing CB1 to the OFF position. Disconnect at least one wire from the power input terminals of the Output Board. The resistance should not be less than 3000 ohms.
  - If the resistance is greater than the acceptable value, go to step 3.
  - If the resistance is less than the acceptable value, the Output Board is defective.

### LED lit, output not energized

If the LED of a suspect is lit but the load connected to it is not energized, and everything is intact between the MCB and the coil side of the relay, perform the following procedure to isolate the problem:

1. Verify that 24 or 120 Vac power is present at the suspect output's screw terminal on the Output Board.
2. Remove power from the controller by placing CB1. Swap the suspect relay with a known good relay. Try to choose a relay that will not affect unit operation. Restore power by closing CB1.
  - If the output load energizes, the suspect relay is bad. Replace the relay.
  - If the output load does not energize (when LED is lit again), check the load circuit wiring and components.

### Output energized, LED not lit

If the LED of a suspect is not lit, but the load connected to it is energized, either the solid-state relay or the MOV is bad. The solid-state relay contacts and the MOV, which are in parallel, can both fail closed. Perform the following procedure to isolate the problem:

1. Remove power from the controller by opening CB1. Pull the solid-state relay from the suspect output's socket.
2. Restore power by closing CB1.
  - If the output load remains energized when there is no relay in the socket, the output's MOV has failed and thus the Output Board must be replaced.
  - If the output load de-energizes, the relay that was pulled is defective.

### Contact chatter

Contact chatter is very rapid opening and closing of contacts. It is usually caused by low voltage at the electromechanical relay or contactor coil. If contact chatter is occurring on a relay or contactor connected to one of the Output Board

solid-state relays, it is also possible that a faulty connection exists on the power supply terminals of the Aux/Out plug connector on the MCB and the Output Board. In very rare instances, contact chatter can be caused by a faulty solid-state relay. Perform the following procedure to isolate the problem:

1. Verify that the voltage at the load's power supply and at the solid-state relay contacts is adequate.
2. Remove power from the controller by opening CB1. Swap the suspect relay with a known good relay. Try to choose a relay that will not affect unit operation. Restore power by

closing CB1.

If the chatter does not stop, go to step 3.

If the chatter stops, the suspect relay is defective. Replace the relay.

3. Remove power from the controller by opening CB1. Try to improve the connections in the Aux/Out plug insulation displacement terminals by pressing down on the wires with a small screwdriver.

4. Check all other wiring and connectors for bent pins or miswires.

If the chatter does not stop, the electromechanical relay or contactor is probably defective.

## Troubleshooting Solid-State Relays

As shown on the unit wiring diagrams, the solid-state relays on the Output Boards all have normally open "contacts." Actually, these contacts do not exist as they do in electromechanical relay. Instead of using contacts to switch the load, the solid-state relay changes its resistance from low (closed), when it is energized, to high (open), when it is de-energized. (This high resistance is approximately 100K ohms.) Because the output circuit through the solid-state relay remains continuous regardless of whether the relay is energized, troubleshooting a solid-state relay with a voltmeter can be tricky.

In a typical circuit, a power source is connected across a single relay output and a load (see Figure 17). In this circuit, a solid-state relay will behave like an electromechanical relay. If the relay is energized, the relay output will be hot. If the relay is de-energized, voltage cannot be measured at the relay output.

The circuit shown in Figure 6 is similar to a typical circuit;

Figure 17a. Testing a typical relay circuit

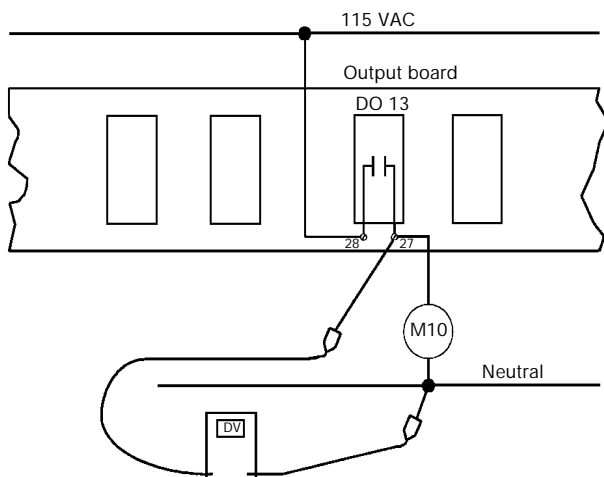

the difference is that there is an open set of contacts, or a disconnection between the relay output and the load. In this circuit, a solid-state relay will not behave like an electromechanical relay. If the solid-state relay is energized, the relay output will be hot (as expected). However, if the solid-state relay is de-energized, the relay output will still appear to be hot. This is because the relay output and the voltmeter form a continuous circuit in which the relay's resistance, though high, is insignificant compared to the voltmeter's resistance.

This means that nearly all the voltage is dropped across the voltmeter. Therefore, the voltmeter indicates that voltage is present. If a low wattage light bulb of the appropriate voltage is used instead of a voltmeter, the bulb's low resistance will load the circuit enough to eliminate the false voltage indication. In this situation, an incandescent test lamp is a better tool than a voltmeter.

Figure 17b. Testing a typical relay circuit with a disconnection

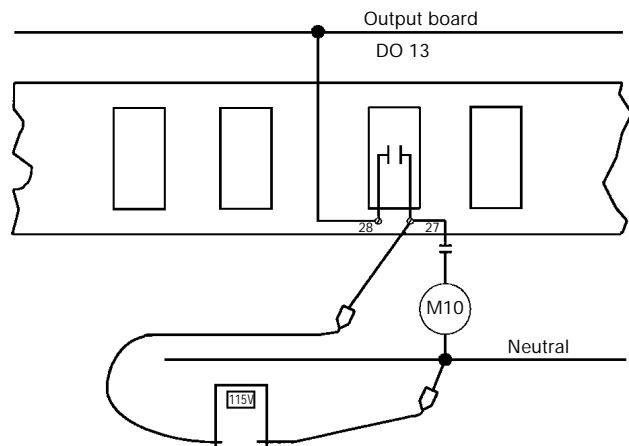

## MCB Replacement

If an MCB board is defective and must be replaced, the proper controller software must be loaded into the replacement MCB. This can be done either at the factory or at the building site—if a PC equipped with appropriate Monitor software is available.

The factory will download the proper controller software into a replacement MCB board before it is shipped if you include the program code with the replacement MCB part order. If the program code is not provided, the MCB board will be shipped without software.

Job-specific Monitor software includes each unit and auxiliary controller's program. Therefore, it is possible to download the proper controller software to a replacement MCB at the building site if a PC equipped with that job's Monitor software is available. In addition, if the controller's configuration data was stored on the PC hard drive prior to the MCB failure, the exact configuration data (including all keypad programmable set points and parameters) can be restored. Refer to the user's manual supplied with the Monitor software for more information.

## Connecting the Communications Trunk

Use the following three procedures to connect the chiller controllers to the network.

### Communications cable check

The network communications cable should have been installed in accordance with the instructions in the “Field Wiring” section of this manual. This procedure will verify that there are no shorts or stray voltages anywhere in the communications trunk.

Before beginning, verify that the port B connectors are disconnected from every controller on the trunk.

1. Verify that there is no voltage between any conductor and ground.

Use a voltmeter to test for voltage at the field wiring terminal block or directly on the port B connector of the level-1 controller. With one lead on the control panel chassis (ground), check for voltage at the “+,” “-,” and “ground” terminals. There should be no AC or DC voltage (see the Signal and Terminal columns of Table 3). If the conductors are properly terminated, this check will test for stray voltage throughout the trunk.

**Note:** If you get a 2 or 3 Vdc reading, it indicates that one or more powered controllers are connected to the trunk. These controllers should be located and disconnected.

2. Verify that there are no shorts between any two conductors.

Use an ohmmeter to test for shorts at field wiring terminal block or directly on the port B connector of the level-1 controller. For the three combinations of conductor pairs, there should be infinite resistance between the conductors. If the conductors are properly terminated, this check will test for shorts throughout the trunk.

**Note:** If you find a resistance that is high but less than infinite, it indicates that one or more non-powered controllers are connected to the trunk. These controllers should be located and disconnected.

3. Verify that the communications wiring is continuous over the trunk and that the field terminations are correct. (This step is optional but recommended; to do it, you must know the physical layout of the network’s communications trunk.)

Go to the last controller on one end of the daisy-chain and place a jumper across the “+” to “ground” and “-” to “ground.”

Remove the jumper and repeat this step for the other two conductor pairs: “+” to “ground” and “-” to “ground.”

If there is continuity for each conductor pair, the wiring is continuous and it is likely (but not guaranteed) that the terminations are correct throughout the trunk.

If there is no continuity for one or more conductor pairs, there may be a break in the trunk or the terminations at one or more controllers may have been mixed up.

Table 13. Port B voltages: AMP type connector

Port B (RS-485)		Acceptable Voltage Reading
Signal	Terminal	
+	4	3.0 ± 0.3 Vdc
-	3	2.0 ± 0.3 Vdc
Ground	5	0.0 ± 0.2 Vdc

Table 14. Network communications field wiring terminals

Controller	Network Comm. Field Terminal		
	+	-	Ground
CSC	T11-B+	T11-B-	T11-GND
Reciprocating Chiller	TB7-138	TB7-137	TB7-139
Screw Chiller	TB4-54	TB4-53	TB4-55

Figure 18. AMP connector terminal configuration

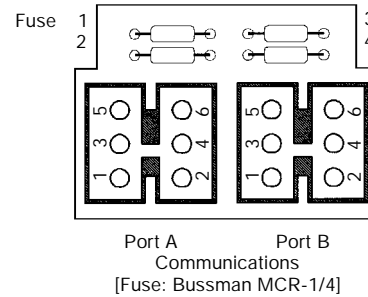

### Level-1 controller connection

In order for the chillers and other level-2 controllers in a network to connect and communicate with the level 1 controller, the level 1 controller is connected first.

1. Set the network address to 00 (level 1). See “Addressing the Controllers” above for more information.
2. Push the circuit breaker (CB1) button to power up the CSC and verify that there is power to the MCB by observing the LEDs.
3. Check the voltages of port B on field wiring terminals (TB2).

Use a DC voltmeter to test for proper voltages. With the ground lead on the control panel chassis (ground), check the voltage at the “+,” “-,” and “ground” terminals. Refer to Table 13 for the correct voltage levels.

If no voltage or improper voltage levels are found, verify that the panel is energized.

4. Plug the network communications AMP connector into port B.

### Level-2 controller connection

This procedure will verify that proper communications have begun for each controller as it is connected to the network. You can connect the level-2 controllers in any order; however, it is better to follow the daisy-chain as you proceed. This will make troubleshooting easier if communications problems occur.

As a result of the previous procedures, the network communications connector should be disconnected from the B port at every controller on the trunk except for the level 1 controller. Be sure that this is true before beginning this procedure.

For communications to occur, each networked controller must have the proper hex switch setting and the proper voltages at its port B terminals.

1. Set the network address (hex switch setting) to match the address on the engineering schedule. Each controller must have a unique address.

- Turn on power to the level-2 controller. Refer to the controller installation manuals for information on how to turn on power to each controller.
- Check the voltages of port B directly on the AMP connector. The trunk must not be connected to the controller when you do this.

Use a DC voltmeter to test for proper voltages. With the ground lead on the control panel chassis (ground), check the voltage at the "+," "-", and "ground" terminals. Refer to Table 13 for the correct voltage levels.

If no voltage or improper voltage levels are found, verify that the controller is energized.

- Check for proper communication trunk voltages at the field wiring terminals (if any) or directly on the connector. The trunk must not be connected to the controller when you do this.

If no voltage or improper voltages are found, check the wiring between the port terminals and the field terminals (if any). using Table 13 and Figure 22, verify that the three conductors are properly terminated in the network communications connector. If there is still a problem, verify that the level-1 controller is energized and that the communications trunk wiring is intact.

- Plug the network connector into port B.
- Verify communications have begun between the level 1 controller and the level-2 controller:

To verify communications using Monitor for Windows software, network diagnostics must be performed. To run network diagnostics, select the pull-down menu "Comm." Select "Network Diagnostic," which will then display the "Network Diagnostics Parameters Setup" dialog box. Using the "Network Diagnostics Parameters Setup" dialog box, you can choose to continually loop the diagnostics, or have a single sweep of each controller being connected to the network. You can also perform the following functions:

- Display Program ID and status
- Restrict display of level-3s to units with errors

- Clear communications errors if found
- Log errors to file

As the different controllers are connected to the network, their information is displayed on the Network Diagnostic Error Display screen. By looking at the headings labeled "Address" and "Error Codes," network communications to a particular controller can be verified. If there are no error codes, network communications to the controller was successful. If the "Error Code" reads "Does not respond," a communications problem has occurred. For more on network diagnostics, see "Chapter 5-Comm Menu" in "MicroTech Monitor for Windows" user's manual.

If a communications problem occurred, check the following items:

- Make sure the hex switches on each controller are set to the correct values.
- Make sure the controller has power supplied to it.
- Make sure the communication line is properly connected to port B.
- Make sure the controller is level 2 by directly connecting the PC to it. (You must know how to change communications passwords to do this.)

- Go to the next controller and repeat steps 1 through 6. Do this for each controller being connected to the network.

**Note:** To verify communications more quickly and easily, use two people in the commissioning of the network. Because some jobs have units located throughout a building, having one person perform the commissioning procedure may be difficult. When there are two people, one person can stay at the PC connected to the level-1 controller and the other person can go to each individual unit controller. Using a radio or other two-way communication equipment, they can indicate when a specific controller is connected and whether communications between the controllers is occurring.

## Keypad Key Functions

The MicroTech keypad consists of twelve pressure sensitive membrane switches (Refer to Figure 11). These keys are used to step through, access, and manipulate the information in the MicroTech controller tree structure. The keypad keys are divided into four groups with two or four keys in each.

### Keypad password

When changing any menu item entry, the user is prompted to enter the password. The change will not be allowed until the correct password is entered. The password for ALS and PFS units is always the successive pressing of the following "ACTION" group keys:

"ENTER" "ENTER" "ENTER" "ENTER"

Once this has been done, the user can make changes to menu item entries. After entering the correct password, the controller will allow a 5 minute time period during which the operator may make any necessary set point adjustments. Any keypad activity will reset the timer for the full 5 minutes so the password only needs to be entered once per session. After 5 minutes of inactivity, the password access time will expire providing protection against unauthorized users.

### Category group

The keys in this group provide quick access to strategic menus throughout the menu tree structure. This reduces the need to step through all the menus, one by one, in order to reach the desired menu.

- STATUS** — Pressing the "STATUS" key at any time shifts the display to Menu #1 (Unit Status) which is the first menu of the STATUS category.
- CONTROL** — Pressing the "CONTROL" key at any time shifts the display to Menu #13 (Control Mode) which is the first menu of the CONTROL category.
- ALARMS** — Pressing the "ALARMS" key at any time shifts the display to Menu #24 (Circ 1 Current Alarm) which is the first menu of the ALARMS category.
- SWITCH** — Pressing the "SWITCH" key at any time toggles the display between the current menu (Status/control) item and the related menu (control/status) item somewhere else in the tree structure. For example, if this key is pressed while the current menu item is menu item 4A (Leaving Evaporator=), the display shifts to menu item 14A (Leaving Evaporator Set point=). This provides for easy review of actual versus set point values.

## Menu group

The keys in this group are for stepping from menu to menu in the menu tree-structure.

- A. **PREV.** — Pressing “PREV.” shifts the display to the previous menu. **Note:** When Menu #1 is currently in the display (the first menu in the menu tree structure), pressing “PREV.” causes an “end of menus” message to appear in the display. Pressing “PREV.” again causes the display to wrap around to Menu #27 (the last menu in the tree structure).
- B. **NEXT** — Pressing “NEXT” shifts the display to the next menu. **Note:** When menu #27 is currently in the display (the last menu in the menu tree structure), pressing “NEXT” causes an “end of menus” message to appear in the display. Pressing “NEXT” again causes the display to wrap around to Menu #1 (the first menu in the menu tree structure).

## Item group

The keys in this group are for stepping from item to item within a menu.

- A. **PREV.** — Pressing “PREV.” shifts the display to the previous item in a menu. **Note:** When the first item in a menu is currently in the display, pressing “PREV.” causes an “end of items” message to appear in the display. Pressing “PREV.” again causes the display to wrap around to the last item in the menu.
- B. **NEXT** — Pressing “NEXT” shifts the display to the next item in a menu. **Note:** When the last item in a menu is currently in the display, pressing “NEXT” causes an “end of items” message to appear in the display. Pressing “NEXT” again causes the display to wrap around to the first item in the menu.

## Action group

The keys in this group are for making changes to unit control parameters or for clearing alarm conditions. **Note:** Before a change to a parameter can be made or before an alarm can be cleared, the display prompts the user with an “Enter Password” message. At this point, the password must be entered before the user can continue with the action.

(“Enter”, “Enter”, “Enter”, “Enter”.)

- A. **INCR.** — When changing the value of a menu item entry, pressing “INCR. +” shifts the menu item display line to the next higher value or next available selection.
- B. **DECR.** — When changing the value of a menu item entry, pressing “DECR.-” shifts the menu item display line to the next lower value or previous available selection.
- C. **ENTER** — Once a change has been made to a desired value, pressing “ENTER” locks in the new value.
- D. **CLEAR** — Pressing “ALARMS” followed by “CLEAR” clears the current alarm. Also, when a change is made to a menu item, pressing “CLEAR” returns the display to the original value as long as “ENTER” has not yet been pressed.  
**Note:** The cause of an alarm should always be determined and corrected before clearing the alarm through the keypad.

## Example of keypad operation

As an example of using the keypad key functions, consider reprogramming the Leaving Evaporator Set point from 44°F to 42°F. This consists of changing the menu item 14A (Leaving Evaporator Set point) entry from “44°F to 42°F.” Assume menu #1 (Unit Status) is currently in the display. The following key sequence is followed:

1. Press the “CATEGORY” group “CONTROL” key one time. This switches the display to menu #13 (the first menu in the “CONTROL” category).
2. Press the “MENU” group “NEXT” key once. This shifts the display to menu item 14A. (Leaving Evaporator Set point).
3. Press the “ACTION” group “DEC-” key one time. This prompts the user to enter the password.  
  
 (“Enter”, “Enter”, “Enter”, “Enter”).
4. After the “Password Verified” message, press the “ACTION” group “DEC-” key four times. This changes the menu item entry to 42°F.
5. Press the “ACTION” group “ENTER” key one time. This stores the new entry into the MicroTech controller memory.
6. Pressing the “CATEGORY” group “STATUS” key then shifts the display back to menu #1.

## Personal Computer Specification

For McQuay Monitor Software

1. IBM PC or 100% true compatible, 486DX or better including:
  - a. **3½” 1.44 MB floppy diskette drive** — utilized for loading the MicroTech Monitor program into the hard disk of the computer. Also provides capability of archiving historical data and system back-up.
  - b. **8 Megabyte RAM (Random Access Memory)** — The computer must have 8 Megabytes in order to run the MicroTech Monitor Program.
  - c. **Asynchronous Serial Communications Adapter** — A direct communications interface connection between the PC and the MicroTech Controller. The communications port must be recognized as COM1 or COM2 and the connector should be a 9 Pin Male.
  - d. **Super VGA Graphics Adapter** — For high resolution graphics and data display.
  - e. **Parallel Printer Port** — For hard-copy custom reports of all accumulated data.
  - f. Bus mouse or trackball.
  - g. **Hard Disk Drive (120 Megabyte min.)** — A mass data storage area for the operator interface and custom report software.
  - h. **101 Enhanced Keyboard** — Required for more advanced functions of the operator interface and custom report software.
  - i. The computer shall include MS-DOS 6.2 or greater, Windows 3.1 or greater and all owner’s manuals.
  - j. The computer shall have an internal time clock that is battery backed to maintain system time and date.
  - k. The computer shall have an internal, 9600-Baud, Hayes compatible modem if remote access and monitoring of the MicroTech unit controller is desired. The modem shall be addressable as Com1 or Com2.

2. **Multisync Super VGA Color Monitor** — For use with the Super VGA graphics.
3. Printer, 192 CPS (Characters Per Second) Epson LQ-510 or equivalent. Must have the ability of supporting IBM extended character graphics.
4. **Printer Cable, 6 Ft. Parallel** — For communications connection between the PC and the printer.

The computer is used for changing set points, monitoring data, trend logging, diagnostics, and remotely clearing alarms within the MicroTech system. The computer is normally a dedicated personal computer, however, the operator may choose to exit the Monitor program from time to time to perform other functions such as word processing or data manipulation using a spreadsheet program. It should be

noted, however, that for maximum convenience and functionality, the computer should be considered a dedicated computer for the MicroTech system.

The communications cable from the unit control panel to the personal computer is shielded, twisted pair wire (Belden #8761 or equal). The communications adheres to the industry standards of RS-232C and the rate of communications is 9600 baud. The recommended maximum distance from the personal computer to the control panel is 50 feet. If the required distance is in excess of 50 feet, an optional RS-232 extension kit is required (contact McQuay).

A voice quality, direct dial telephone line is required in remote access and monitoring of the unit controller is desired. The phone line should be terminated with a standard RJ-11C modular phone plug.

## MicroTech Menu Structure

A complete listing of the information stored in the MicroTech controller tree structure is shown in the following tables. This table shows the menu numbers and names along with their corresponding menu items and menu item entries as they appear on the MicroTech display. The # symbol is used where the controller would normally display a numerical value. Also included in this figure is the corresponding switch menu for each menu item.

### Notes:

1. **Status Category** — Where more than one menu item entry is listed under a menu item, the list includes all the entries which can appear in the display for the particular item. The entry that shows in the display depends on the operating status of the unit.
2. **Control Category** — Where more than one menu item entry is listed under a menu item, the list includes all the choices from which the user can select. The selected entry appears in the display.
3. **Alarm Category** — The entries listed include all the possible alarm messages. The display reads the alarm conditions which occur.

### Status menus

Provide chiller operating information as and display of sensor readings. The items listed under these status menus are affected by the settings under the associated control menus and are not directly adjusted via the keypad.

### Control menus

All adjustable control parameters and set points, time schedules, control options and alarm thresholds are accessed through these menus.

### CAUTION

**Any changes to these parameters must be determined and implemented by qualified personnel with a thorough understanding of how these parameters affect the operation of the unit. Negligent or improper adjustment of these controls may result in damage to the unit or personal injury.**

### Alarm menus

Display any alarm conditions which may be present in the unit. All alarm messages are accompanied by the date and time when the alarm occurred.

# Menus for Two (2) Screw Compressors Units

## Menu 1. Chiller status

Screen	Display
1	OFF: Manual Mode
	System Sw
	Remote Comm
	Remote Sw
	Time Clock
	Alarm
	PumpDnSw's
	Starting
	WaitForLoad
	CoolStageDn
	CoolStageUp
	CoolStaging #
	Manual Cool
	2
3	Hold Stage min
4	Hi Loop Temp=

## Menu 2. Circ #1 status

Screen	Display
1	OFF: SystemSw
	ManualMde
	Alarm
	PumpDwnSw
	CycleTime xx
	WaitFlooded
	waitFlodded xxx
	Ready
	PumpingDown
	Starting
	Pre-Purge
	Opened EXV
	LowAmbStart
	Cooling %Cap=xxx

## Menu 3. Circ #2 status

Screen	Display
1	OFF: SystemSw
	ManualMde
	Alarm
	PumpDwnSw
	CycleTime xx
	WaitFlooded
	waitFlodded xxx
	Ready
	PumpingDown
	Starting
	Pre-Purge
	Opened EXV
	LowAmbStart
	Cooling %Cap=xxx

## Menu 4. Water temp's

Screen	Display
1	Lvg Evap= xxx.x °F (°C)
	Short °F (°C)
	Open °F (°C)
2	Ent Evap= xxx.x °F (°C)
	Short °F (°C)
	Open °F (°C)
3	Ent Cond= xxx.x °F (°C)
	Short °F (°C)
	Open °F (°C)
4	Lvg Cond= xxx.x °F (°C)
	Short °F (°C)
	Open °F (°C)

## Menu 5. Circ #1 pres's

Screen	Display
1	Evap= xxx.x psi(kPa) xx°F (°C)
	Evap 145 +psi(kPa) **°F (°C)
	Open N/A ** F (C)
	Short N/A **F
2	Cond xxx.x psi (kPa) xxx°
	Cond 450+ psi (kPa) xxx°
	Open N/A ** F (C)
	Short N/A **F
3	MinCondPr = 0#
4	MaxCondPr = 0#
5	EXV Position= xxx
6	Cond Fan Stage = x

## Menu 6. Circ #2 pres's

Screen	Display
1	Evap= xxx.x psi(kPa) xx°F (°C)
	Evap 145 +psi(kPa) **°F (°C)
	Open N/A ** F (C)
	Short N/A **F
2	Cond xxx.x psi (kPa) xxx°
	Cond 450+ psi (kPa) xxx°
	Open N/A ** F (C)
	Short N/A **F
3	MinCondPr = 0#
4	MaxCondPr = 0#
5	EXV Position= xxx
6	Cond Fan Stage = x

## Menu 7. Circ #1 Temp's

Screen	Display
1	Satur Evap=xxx°F (°C)
	N/A **°F (°C)
2	SuctLine = xxx.x°F (°C)
	Open °F (°C)
3	Short °F (°C)
	Super Ht =xxx.x°F (°C)
4	N/A ** °F (°C)
	Satur Cond = xxx°F (°C)
5	N/A **°F (°C)
	Liquid Ln = xxx.x°F (°C)
6	N/A ** °F (°C)
	SubCoolg= xxx.x°F (°C)
7	N/A ** °F (°C)
	Dscharge=xxx.x°F (°C)
	Open °F (°C)
	Short °F (°C)

**Menu 8. Circ #2 temp's**

Screen	Display
1	Satur Evap=xxx°F (°C)
	N/A **°F (°C)
2	SuctLine = xxx.x°F (°C)
	Open °F (°C)
	Short
3	Super Ht = xxx.x°F (°C)
	N/A ** °F (°C)
4	Satur Cond = xxx°F (°C)
	N/A **°F (°C)
5	Liquid Ln = xxx.x°F (°C)
	N/A ** °F (°C)
6	SubCoolg= xxx.x°F (°C)
	N/A ** °F (°C)
7	Dscharge=xxx.x°F (°C)
	Open °F (°C)
	Short °F (°C)

**Menu 9. Chiller amps**

Screen	Display
1	PercentRLA=xxx%

**Menu 13. Control mode**

Screen	Display	Factory Set Point	Range
1	Manual Unit Off	Manual Unit Off	
	Automatic		
	Manual Staging		
	Service Testing		
2	Manual Stage=xx	0	1-8

**Menu 14a. Lvg evap spts — values for R-22 refrigerant**

Screen	Display	Factory Set Point	Range
1	Actv Spt=xxx.x °F (°C)		Not Changeable
2	Lvg Evap=xxx.x °F (°C)	44 (6.7)	10-80 (-12.2-26.7)
3	CntrlBand x.x °F (°C)	3.0 (1.6)	1.0-5.0 (0.5-2.7)
4	StartUpD-T= x.x °F (°C)	3.0 (1.6)	1.0-5.0 (0.5-2.7)
5	ShutDn D-T= x.x °F (°C)	1.5 (0.8)	0.0-3.0 (0.0-1.6)
6	MaxPullDn= x.x °F (°C)	0.5 (0.2)	0.1-1.0 (0.0-0.5)
7	ResetOpt=None	None	
	Return		
	4-40 Ma		
	Network		
	Ice		
	Outdoor		
8	ResetSig= xx.xma		Not Changeable
9	MaxChWRst=xx.x °F (°C)	10.0 (5.5)	0.0-45.0 (0.0-25.0)
10	ReturnSpt= xx.x °F (°C)	54.0 (12.3)	15.0-80.0 (-9.4-26.7)
11	OatBegRst= xx.x °F (°C)	75.0 (23.9)	0.0-90.0 ([-17.8]-32.2)
12	OatMaxRst= xx.x °F (°C)	60.0 (15.5)	0.0-90.0 ([-17.8]-32.2)
13	HiChWTmp= xxx.x °F (°C)	60.0 (15.5)	20.0-90.0 (-6.6-32.2)

**Note:** ( ) indicates Centigrade values; [ ] the minus sign is not displayed with three digit numbers

**Menu 10. Comp run hours**

Screen	Display
1	#1Total=xxxxxx
2	#2Total=xxxxxx
3	#1 @ 25%=xxxxxx
4	#1 @ 50%=xxxxxx
5	#1 @ 75%=xxxxxx
6	#1 @100%=xxxxxx
7	#2 @ 25%=xxxxxx
8	#2 @ 50%=xxxxxx
9	#2 @ 75%=xxxxxx
10	#2 @100%=xxxxxx

**Menu 11. Compr starts**

Screen	Display
1	#1 Total=xxxxxx
2	#2 Total=xxxxxx

**Menu 12. Air temp**

Screen	Display
1	OutDoor = xxx.x°F(°C)



*Menu 14b. Lvg evap spts — values for 134a refrigerant*

Screen	Display	Factory Set Point	Range
1	Actv Spt=xxx.x °F (°C)		Not Changeable
2	Lvg Evap=xxx.x °F (°C)	44 (6.7)	10-80 (-6.6-26.7)
3	CntrlBand x.x °F (°C)	3.0 (1.6)	1.0-5.0 (0.5-2.7)
4	StartUpD-T= x.x °F (°C)	3.0 (1.6)	1.0-5.0 (0.5-2.7)
5	ShutDn D-T= x.x °F (°C)	1.5 (0.8)	0.0-3.0 (0.0-1.6)
6	MaxPullDn= x.x °F (°C)	0.5 (0.2)	0.1-1.0 (0.0-0.5)
7	ResetOpt=None	None	
	Return		
	4-40 Ma		
	Network		
	Ice		
8	ResetSig= xx.xma		Not Changeable
9	MaxChWRst=xx.x °F (°C)	10.0 (5.5)	0.0-45.0 (0.0-25.0)
10	ReturnSpt= xx.x °F (°C)	54.0 (12.3)	15.0-80.0 (-9.4-26.7)
11	OaTBegRst= xx.x °F (°C)	75.0 (23.9)	0.0-90.0 (-3.9-32.2)
12	OatMaxRst= xx.x °F (°C)	60.0 (15.5)	0.0-90.0 ([-17.8]-32.2)
13	HiChWTmp= xxx.x °F (°C)	60.0 (15.5)	20.0-90.0 (-6.6-32.2)

**Note:** ( ) indicates Centigrade values; [ ] the minus sign is not displayed with three digit numbers

*Menu 15. Soft load spts*

Screen	Display	Factory Set Point	Range
1	Time Left= xxmin		
2	SoftLoad= xx min	20	0-254
3	SoftLdMaxStg= x	7	1-8
4	LoadDelay= xxsec	15	0-254

*Menu 16. Compressor spt*

Screen	Display	Factory Set Point	Range
1	LeadCircuit=Auto	Auto	#1-#2
2	InterStg= xxx sec	210	60-480
3	MinST-ST=xx min	15	5-40
4	MinSP-ST xx min	5	3-30

*Menu 17a. Head pres spt — values for R-22 refrigerant*

Screen	Display	Factory Set Point	Range
1	MinLift 25%=xxx	70 (483)	60-100 (414-690)
2	MinLift 50%=xxx	80 (552)	70-100 (483-690)
3	MinLift100%=xxx	140 (966)	100-140 (690-966)
4	DeadBandMult= x.x	1.0	.8-1.3
5	StageUpErr= xxx	400 (2760)	300-990 (2070-6830)
6	StageDnErr = xxx	100 (690)	50-400 (340-2760)

**Notes:** ( ) indicates Centigrade values

*Menu 17b. Head pres spt — values for 134a refrigerant*

Screen	Display	Factory Set Point	Range
1	MinLift 25%=xxx	50 (345)	40-60 (276-414)
2	MinLift 50%=xxx	56 (386)	50-80 (345-552)
3	MinLift100%=xxx	90 (621)	80-122 (552-841)
4	DeadBandMult= x.x	1.0	.8-1.3
5	StageUpErr= xxx	400 (2760)	300-990 (2070-6830)
6	StageDnErr = xxx	100 (690)	50-400 (340-2760)

**Notes:** ( ) indicates Centigrade values

*Menu 18. Demand limits*

Screen	Display	Factory Set Point	Range
1	Demand Lim= xstg	3	Not Changeable at this screen
2	DemandSg= xx.x ma	Actual Value	Indicates the Magnitude of the Demand Limit Signal

*Menu 19. Time/date*

Screen	Display	Factory Set Point	Range
1	Time= xx:xx:xx		Actual Time
2	Mon xx/xx/xx		Actual Day and Date

*Menu 20. Schedule*

Screen	Display	Factory Set Point	Range
1	Override= xx.xx hr	0.00 Hr	00:00-63.50
2	NMPSchedule= N/A	N/A	1-32
3	Sun 00:00-23:59	00:00-23:59	00:00-23:59
4	Mon 00:00-23:59	00:00-23:59	00:00-23:59
5	Tue 00:00-23:59	00:00-23:59	00:00-23:59
6	Wed 00:00-23:59	00:00-23:59	00:00-23:59
7	Thu 00:00-23:59	00:00-23:59	00:00-23:59
8	Fri 00:00-23:59	00:00-23:59	00:00-23:59
9	Sat 00:00-23:59	00:00-23:59	00:00-23:59
10	Hol 00:00-23:59	00:00-23:59	00:00-23:59

*Menu 21. Holiday date*

Screen	Display	Factory Set Point	Range
1	#1 Date = N/A 0	N/A 0	Jan-Dec 1-31
2	#1 Dur = 0 Day(s)	0	0-31
3	#2 Date = N/A 0	N/A 0	Jan-Dec 1-31
4	#2 Dur = 0 Day(s)	0	0-31
5	#3 Date = N/A 0	N/A 0	Jan-Dec 1-31
6	#3 Dur = 0 Day(s)	0	0-31
7	#4 Date = N/A 0	N/A 0	Jan-Dec 1-31
8	#4 Dur = 0 Day(s)	0	0-31
9	#5 Date = N/A 0	N/A 0	Jan-Dec 1-31
10	#5 Dur = 0 Day(s)	0	0-31
11	#6 Date = N/A 0	N/A 0	Jan-Dec 1-31
12	#6 Dur = 0 Day(s)	0	0-31
13	#7 Date = N/A 0	N/A 0	Jan-Dec 1-31
14	#7 Dur = 0 Day(s)	0	0-31
15	#8 Date = N/A 0	N/A 0	Jan-Dec 1-31
16	#8 Dur = 0 Day(s)	0	0-31
17	#9 Date = N/A 0	N/A 0	Jan-Dec 1-31
18	#9 Dur = 0 Day(s)	0	0-31
19	#10 Date = N/A 0	N/A 0	Jan-Dec 1-31
20	#10 Dur = 0 Day(s)	0	0-31
21	#11 Date = N/A 0	N/A 0	Jan-Dec 1-31
22	#11 Dur = 0 Day(s)	0	0-31
23	#12 Date = N/A 0	N/A 0	Jan-Dec 1-31
24	#12 Dur = 0 Day(s)	0	0-31
25	#13 Date = N/A 0	N/A 0	Jan-Dec 1-31
26	#13 Dur = 0 Day(s)	0	0-31
27	#14 Date = N/A 0	N/A 0	Jan-Dec 1-31
28	#14 Dur = 0 Day(s)	0	0-31

*Menu 22. Service test*

Screen	Display	Factory Set Point	Range
1	#0 Output 0=Off	Off	On-Off
2	#1 Output 1=Off	Off	On-Off
3	#2 EXV Pos#1=xxx		0-760
4	#3 EXV Pos#2=xxx		0-760
5	#4 Output 4=Off	Off	On-Off
6	#5 Output 5=Off	Off	On-Off
7	#6 Output 6=Off	Off	On-Off
8	#7 Output 7=Off	Off	On-Off
9	#8 Output 8=Off	Off	On-Off
10	#9 Output 9=Off	Off	On-Off
11	#10 Output 10=Off	Off	On-Off
12	#11 Output 11=Off	Off	On-Off
13	#12 Output 12=Off	Off	On-Off
14	#13 Output 13=Off	Off	On-Off
15	#14 Output 14=Off	Off	On-Off
16	#15 Output 15=Off	Off	On-Off
17	#16 Output 16=Off	Off	On-Off
18	#17 Output 17=Off	Off	On-Off
19	#18 Output 18=Off	Off	On-Off
20	#19 Output 19=Off	Off	On-Off
21	#20 DH1=00000000		Digital Input ( 0-Open ) ( 1-Closed )
22	#21 DH2=00000000		Digital Input ( 0-Open ) ( 1-Closed )
23	#22 AI#5= x.xx Vdc		Actual Vdc Value

*Menu 23a. Alarm spts — values for R-22 refrigerant*

Screen	Display	Factory Set Point	Range
1	StpPumpDn =xxpsi (kPa)	34 (234)	2-54 (13-372)
2	FullPumpDown= No	No	No-yes
3	FreezStat= xxpsi (kPa)	54 (372)	20-60 (138-414)
4	FreezH2O= xx.x °F (°C)	36.0 (2.3)	0.0-40.0 (-17.5-4.5)
5	Hi Press = xxxpsi (kPa)	380 (2622)	280-426 (1932-2939)

Note: ( ) indicates Centigrade value

*Menu 23b. Alarm spts — values for 134a refrigerant*

Screen	Display	Factory Set Point	Range
1	StpPumpDn =xxpsi (kPa)	14 (96)	2-22 (13-151)
2	FullPumpDown= No	No	No-yes
3	FreezStat= xxpsi (kPa)	26 (179)	4-26 (27-179)
4	FreezH2O= xx.x °F (°C)	36.0 (2.3)	0.0-40.0 (-17.5-4.5)
5	Hi Press = xxxpsi (kPa)	276 (1904)	180-326 (1242-2249)

Note: ( ) indicates Centigrade value

*Menu 24. Misc setup*

Screen	Display	Factory Set Point	Range
1	Unit Type= ALS125		
	ALS140		
	ALS155		
	ALS170		
	ALS175		
	ALS185		
	ALS195		
	PFS150		
	PFS165		
	PFS180		
2	Units = English	English	English-Metric
3	SpeedTrol = No	No	No-Yes
4	Power = 60 hz	60	60-50
5	Port A Baud=xxxx	9600	9600-2400-1200
6	Pre-Alarm=Blink	Blink	Blink-Open-Closed
	Open		
	Closed		
7	Alarm=Closed	Closed	Closed-Blink(N/O)-Blink(N/C)
	Blink(N/O)		
	Blink(N/C)		
8	OAT Select=None	None	None-Lcl-Rmt
	Lcl		
	Rmt		
9	LvgEvpAdj= 0.0 °F(°C)		-0.8-0.8 (-0.4-0.5)
8	EntEvpAdj= 0.0 °F(°C)		-0.8-0.8 (-0.4-0.5)
11	#1EvpAdj= 0.0psi (kPa)		(-13.8-13.8)
13	#2EvpAdj= 0.0psi (kPa)		(-13.8-13.8)
12	#1CndAdj= 0.0psi (kPa)		(-13.8-13.8)
13	#2CndAdj= 0.0psi (kPa)		(-13.8-13.8)
14	Refrigerant= R22		Not Changeable
15	IDENT = SC2-X18B		Not Changeable

*Menu 25. #1 curr alarm*

Screen	Display
1	Current Alarm
2	@ 0:00 0/00/00
3	Evap = x.x psi (kPa)
4	Cond = x.x psi (kPa)
5	SuctLine=xxx.x °F(°C)
6	LiquisLn=xxx.x °F(°C)
7	Evap Lvg=xxx.x °F(°C)
8	OA/LCnWT=xx.xx°F(°C)
9	Capacity= xxx%
10	Fan Stage = x

*Menu 26. #2 curr alarm*

Screen	Display
1	Current Alarm
2	@ 0:00 0/00/00
3	Evap = x.x psi (kPa)
4	Cond = x.x psi (kPa)
5	SuctLine=xxx.x °F(°C)
6	LiquisLn=xxx.x °F(°C)
7	Evap Lvg=xxx.x °F(°C)
8	OA/LCnWT=xx.xx°F(°C)
9	Capacity= xxx%
10	Fan Stage = x

*Menu 27. #1 Prev alarm*

Screen	Display
1	1 Current Alarm
2	1 x:xx x/xx/xx
3	2 Current Alarm
4	2 x:xx x/xx/xx
5	3 Current Alarm
6	3 x:xx x/xx/xx
7	4 Current Alarm
8	4 x:xx x/xx/xx
9	5 Current Alarm
10	5 x:xx x/xx/xx

*Menu 28. #2 Prev alarm*

Screen	Display
1	1 Current Alarm
2	1 x:xx x/xx/xx
3	2 Current Alarm
4	2 x:xx x/xx/xx
5	3 Current Alarm
6	3 x:xx x/xx/xx
7	4 Current Alarm
8	4 x:xx x/xx/xx
9	5 Current Alarm
10	5 x:xx x/xx/xx

**Menus for Three (3) Screw Compressors Units**

*Menu 1. Chiller status*

Screen	Display
1	OFF: Manual Mode
	System Sw
	Remote Comm
	Remote Sw
	Time Clock
	Alarm
	PumpDnSw's
	Starting
	WaitForLoad
	CoolStageDn
	CoolStageUp
	CoolStaging #
	Manual Cool
	2
3	Hold Stage min
4	Hi Loop Temp=

*Menu 3. Circ #2 status*

Screen	Display
1	OFF: SystemSw
	ManualMde
	Alarm
	PumpDwnSw
	CycleTime xx
	WaitFlooded
	waitFlooded xxx
	Ready
	PumpingDown
	Starting
	Pre-Purge
	Opened EXV
	LowAmbStart
	Cooling %Cap=xxx

*Menu 2. Circ #1 status*

Screen	Display
1	OFF: SystemSw
	ManualMde
	Alarm
	PumpDwnSw
	CycleTime xx
	WaitFlooded
	waitFlooded xxx
	Ready
	PumpingDown
	Starting
	Pre-Purge
	Opened EXV
	LowAmbStart
	Cooling %Cap=xxx

*Menu 4. Circ #3 status*

Screen	Display
1	OFF: SystemSw
	ManualMde
	Alarm
	PumpDwnSw
	CycleTime xx
	WaitFlooded
	waitFlooded xxx
	Ready
	PumpingDown
	Starting
	Pre-Purge
	Opened EXV
	LowAmbStart
	Cooling %Cap=xxx

*Menu 5. Water temp's*

Screen	Display
1	Lvg Evap= xxx.x °F (°C)
	Short °F (°C)
	Open °F (°C)
2	Ent Evap= xxx.x °F (°C)
	Short °F (°C)
	Open °F (°C)
3	Ent Cond= xxx.x °F (°C)
	Short °F (°C)
	Open °F (°C)
4	Lvg Cond= xxx.x °F (°C)
	Short °F (°C)
	Open °F (°C)

*Menu 6. Circ #1 pres's*

Screen	Display
1	Evap= xxx.x psi(kPa) xx°F (°C)
	Evap 145 +psi(kPa) **°F (°C)
	Open N/A ** °F (°C)
	Short N/A **°F (°C)
2	Cond xxx.x psi (kPa) xxx°
	Cond 450+ psi (kPa) xxx°
	Open N/A **°F (°C)
	Short N/A **°F (°C)
3	MinCondPr = 0#
4	MaxCondPr = 0#
5	EXV Position= xxx
6	Cond Fan Stage = x

*Menu 7. Circ #2 pres's*

Screen	Display
1	Evap= xxx.x psi(kPa) xx°F (°C)
	Evap 145 +psi(kPa) **°F (°C)
	Open N/A ** °F (°C)
	Short N/A **°F (°C)
2	Cond xxx.x psi (kPa) xxx°
	Cond 450+ psi (kPa) xxx°
	Open N/A ** °F (°C)
	Short N/A **°F (°C)
3	MinCondPr = 0#
4	MaxCondPr = 0#
5	EXV Position= xxx
6	Cond Fan Stage = x

*Menu 8. Circ #3 pres's*

Screen	Display
1	Evap= xxx.x psi(kPa) xx°F (°C)
	Evap 145 +psi(kPa) **°F (°C)
	Open N/A ** °F (°C)
	Short N/A **°F (°C)
2	Cond xxx.x psi (kPa) xxx°
	Cond 450+ psi (kPa) xxx°
	Open N/A ** °F (°C)
	Short N/A **°F (°C)
3	MinCondPr = 0#
4	MaxCondPr = 0#
5	EXV Position= xxx
6	Cond Fan Stage = x

*Menu 9. Circ #1 temp's*

Screen	Display
1	Satur Evap=xxx°F (°C)
	N/A **°F (°C)
2	SuctLine = xxx.x°F (°C)
	Open °F (°C)
3	Super Ht =xxx.x°F (°C)
	N/A ** °F (°C)
4	Satur Cond = xxx°F (°C)
	N/A **°F (°C)
5	Liquid Ln = xxx.x°F (°C)
	N/A ** °F (°C)
6	SubCoolg= xxx.x°F (°C)
	N/A ** °F (°C)
7	Dscharge=xxx.x°F (°C)
	Open °F (°C)
	Short °F (°C)

*Menu 10. Circ #2 temp's*

Screen	Display
1	Satur Evap=xxx°F (°C)
	N/A **°F (°C)
2	SuctLine = xxx.x°F (°C)
	Open °F (°C)
	Short°F (°C)
3	Super Ht =xxx.x°F (°C)
	N/A ** °F (°C)
4	Satur Cond = xxx°F (°C)
	N/A **°F (°C)
5	Liquid Ln = xxx.x°F (°C)
	N/A ** °F (°C)
6	SubCoolg= xxx.x°F (°C)
	N/A ** °F (°C)
7	Dscharge=xxx.x°F (°C)
	Open °F (°C)
	Short °F (°C)

*Menu 11. Circ #3 temp's*

Screen	Display
1	Satur Evap=xxx°F (°C)
	N/A **°F (°C)
2	SuctLine = xxx.x°F (°C)
	Open °F (°C)
	Short°F (°C)
3	Super Ht =xxx.x°F (°C)
	N/A ** °F (°C)
4	Satur Cond = xxx°F (°C)
	N/A **°F (°C)
5	Liquid Ln = xxx.x°F (°C)
	N/A ** °F (°C)
6	SubCoolg= xxx.x°F (°C)
	N/A ** °F (°C)
7	Dscharge=xxx.x°F (°C)
	Open °F (°C)
	Short °F (°C)

*Menu 12. Chiller amps*

Screen	Display
1	#1 PrcntRLA=xxx%
	N/A %
2	#2 PrcntRLA=xxx%
	N/A %
3	#3 PrcntRLA=xxx%
	N/A %

**Menu 13. Comp run hours**

Screen	Display
1	#1Total=xxxxxx
2	#2Total=xxxxxx
3	#3Total=xxxxxx
4	#1 @ 25%=xxxxxx
5	#1 @ 50%=xxxxxx
6	#1 @ 75%=xxxxxx
7	#1 @100%=xxxxxx
8	#2 @ 25%=xxxxxx
9	#2 @ 50%=xxxxxx
10	#2 @ 75%=xxxxxx
11	#2 @100%=xxxxxx
12	#3 @ 25%=xxxxxx
13	#3 @ 50%=xxxxxx
14	#3 @ 75%=xxxxxx
15	#3 @100%=xxxxxx

**Menu 14. Compr starts**

Screen	Display
1	#1 Total=xxxxxx
2	#2 Total=xxxxxx
3	#3 Total=xxxxxx

**Menu 15. Air temp**

Screen	Display
1	OutDoor = xxx.x °F(°C)

**Menu 16. Control mode**

Screen	Display	Factory Set Point	Range
1	Manual Unit Off	Manual Unit Off	
	Automatic		
	Manual Staging		
	Service Testing		

**Menu 17a. Lvg evap spts - values for R-22 refrigerant**

Screen	Display	Factory Set Point	Range
1	Actv Spt=xxx.x °F (°C)		Not Changeable
2	Lvg Evap=xxx.x °F (°C)	44 (6.7)	10 - 80 (-12.2 - 26.7)
3	CntrlBand x.x °F (°C)	3.0 (1.6)	1.0 - 5.0 (0.5 - 2.7)
4	StartUpD-T= x.x °F (°C)	3.0 (1.6)	1.0 - 5.0 (0.5 - 2.7)
5	ShutDn D-T= x.x °F (°C)	1.5 (0.8)	0.0 - 3.0 (0.0 - 1.6)
6	MaxPullDn= x.x °F (°C)	0.5 (0.2)	0.1 - 1.0 (0.0 - 0.5)
7	ResetOpt=None	None	
	Return		
	4-40 Ma		
	Network		
	Ice		
8	Outdoor		
	ResetSig= xx.xma		
9	MaxChWRst=xx.x °F (°C)	10.0 (5.5)	0.0 - 45.0 (0.0 - 25.0)
10	ReturnSpt= xx.x °F (°C)	54.0 (12.3)	15.0 - 80.0 (-9.4 - 26.7)
11	No OaTRst= xx.x °F (°C)	75.0 (23.9)	0.0 - 90.0 ([-17.8] - 32.2)
12	MaxOaTRst= xx.x °F (°C)	60.0 (15.5)	0.0 - 90.0 ([-17.8] - 32.2)
13	HiChWTmp= xxx.x °F (°C)	60.0 (15.5)	20.0 - 90.0 (-6.6 - 32.2)
14	Amb Lock= xxx.x °F (°C)	30.0 (-1.1)	0.0 - 90.0 (-17.8 - 32.2)

**Note:** [ ] the minus sign is not displayed with three digit numbers; ( ) indicates Centigrade values.

*Menu 17b. Lvg evap spts — values for 134a refrigerant*

Screen	Display	Factory Set Point	Range
1	Actv Spt=xxx.x °F (°C)		Not Changeable
2	Lvg Evap=xxx.x °F (°C)	44 (6.7)	10-80 (-6.6-26.7)
3	CntrlBand x.x °F (°C)	3.0 (1.6)	1.0-5.0 (0.5-2.7)
4	StartUpD-T= x.x °F (°C)	3.0 (1.6)	1.0-5.0 (0.5-2.7)
5	ShutDn D-T= x.x °F (°C)	1.5 (0.8)	0.0-3.0 (0.0-1.6)
6	MaxPullDn= x.x °F (°C)	0.5 (0.2)	0.1-1.0 (0.0-0.5)
7	ResetOpt=None	None	
	Return		
	4-40 Ma		
	Network		
	Ice		
8	ResetSig= xx.xma		Not Changeable
9	MaxChWRst=xx.x °F (°C)	10.0 (5.5)	0.0-45.0 (0.0-25.0)
10	ReturnSpt= xx.x °F (°C)	54.0 (12.3)	15.0-80.0 (-9.4-26.7)
11	No OaTRst= xx.x °F (°C)	75.0 (23.9)	0.0-90.0 (-3.9-32.2)
12	MaxOaTRst= xx.x °F (°C)	60.0 (15.5)	0.0-90.0 ([-17.8]-32.2)
13	HiChWTmp= xxx.x °F (°C)	60.0 (15.5)	20.0-90.0 (-6.6-32.2)
14	Amb Lock= xxx.x °F (°C)	30.0 (-1.1)	0.0-90.0 (-17.8-32.2)

**Note:** [ ] the minus sign is not displayed with three digit numbers; ( ) indicates Centigrade values.

*Menu 18. Soft load spts*

Screen	Display	Factory Set Point	Range
1	Time Left= xxmin		
2	SoftLoad= xx min	20	0-254
3	SoftLdMaxStg= x	7	1-8
4	LoadDelay= xxsec	15	0-254

*Menu 19. Compressor spt*

Screen	Display	Factory Set Point	Range
1	Lead/Lag=Auto	Auto	
	1->2->3		
	1->3->2		
	2->1->3		
	2->3->1		
	3->1->2		
2	InterStg= xxx sec	210	60-480
3	MinST-ST=xx min	15	5-40
4	MinSP-ST xx min	5	3-30

*Menu 20a. Head pres spt — values for R-22 refrigerant*

Screen	Display	Factory Set Point	Range
1	MinLift 25%=xxx	70 (483)	60-100 (414-690)
2	MinLift 50%=xxx	80 (552)	70-100 (483-690)
3	MinLift 100%=xxx	140 (966)	100-140 (690-966)
4	DeadBandMult= x.x	1.0	.8-1.3
5	StageUpErr= xxx	400 (2760)	300-990 (2070-6830)
6	StageDnErr = xxx	100 (690)	50-400 (340-2760)

**Note:** ( ) indicates Centigrade values.

*Menu 20b. Head pres spt — values for 134a refrigerant*

Screen	Display	Factory Set Point	Range
1	MinLift 25%=xxx	50 (345)	40-60 (276-414)
2	MinLift 50%=xxx	56 (386)	50-80 (345-552)
3	MinLift 100%=xxx	90 (621)	80-122 (552-841)
4	DeadBandMult= x.x	1.0	.8-1.3
5	StageUpErr= xxx	400 (2760)	300-990 (2070-6830)
6	StageDnErr = xxx	100 (690)	50-400 (340-2760)

**Note:** ( ) indicates Centigrade values.

*Menu 21. Demand limits*

Screen	Display	Factory Set Point	Range
1	Demand Lim= xstg	3	Not Changeable at this screen
2	DemandSg= xx.x ma	Actual Value	Indicates the Magnitude of the Demand Limit Signal

*Menu 22. Time/date*

Screen	Display	Factory Set Point	Range
1	Time= xx:xx:xx		Actual Time
2	Mon xx/xx/xx		Actual Day and Date

*Menu 23. Schedule*

Screen	Display	Factory Set Point	Range
1	Override= xx.xx hr	0.00 Hr	00:00-63.50
2	NMPSchedule= N/A	N/A	1-32
3	Sun 00:00-23:59	00:00-23:59	00:00-23:59
4	Mon 00:00-23:59	00:00-23:59	00:00-23:59
5	Tue 00:00-23:59	00:00-23:59	00:00-23:59
6	Wed 00:00-23:59	00:00-23:59	00:00-23:59
7	Thu 00:00-23:59	00:00-23:59	00:00-23:59
8	Fri 00:00-23:59	00:00-23:59	00:00-23:59
9	Sat 00:00-23:59	00:00-23:59	00:00-23:59
10	Hol 00:00-23:59	00:00-23:59	00:00-23:59

*Menu 24. Holiday date*

Screen	Display	Factory Set Point	Range
1	#1 Date = N/A 0	N/A 0	Jan-Dec 1-31
2	#1 Dur = 0 Day(s)	0	0-31
3	#2 Date = N/A 0	N/A 0	Jan-Dec 1-31
4	#2 Dur = 0 Day(s)	0	0-31
5	#3 Date = N/A 0	N/A 0	Jan-Dec 1-31
6	#3 Dur = 0 Day(s)	0	0-31
7	#4 Date = N/A 0	N/A 0	Jan-Dec 1-31
8	#4 Dur = 0 Day(s)	0	0-31
9	#5 Date = N/A 0	N/A 0	Jan-Dec 1-31
10	#5 Dur = 0 Day(s)	0	0-31
11	#6 Date = N/A 0	N/A 0	Jan-Dec 1-31
12	#6 Dur = 0 Day(s)	0	0-31
13	#7 Date = N/A 0	N/A 0	Jan-Dec 1-31
14	#7 Dur = 0 Day(s)	0	0-31
15	#8 Date = N/A 0	N/A 0	Jan-Dec 1-31
16	#8 Dur = 0 Day(s)	0	0-31
17	#9 Date = N/A 0	N/A 0	Jan-Dec 1-31
18	#9 Dur = 0 Day(s)	0	0-31
19	#10 Date = N/A 0	N/A 0	Jan-Dec 1-31
20	#10 Dur = 0 Day(s)	0	0-31
21	#11 Date = N/A 0	N/A 0	Jan-Dec 1-31
22	#11 Dur = 0 Day(s)	0	0-31
23	#12 Date = N/A 0	N/A 0	Jan-Dec 1-31
24	#12 Dur = 0 Day(s)	0	0-31
25	#13 Date = N/A 0	N/A 0	Jan-Dec 1-31
26	#13 Dur = 0 Day(s)	0	0-31
27	#14 Date = N/A 0	N/A 0	Jan-Dec 1-31
28	#14 Dur = 0 Day(s)	0	0-31



Menu 25. Service test

Screen	Display	Factory Set Point	Range
1	#0 Output 0=Off	Off	On-Off
2	#1 Output 1=Off	Off	On-Off
3	#2 EXV Pos#1=xxx		0-760
4	#3 EXV Pos#2=xxx		0-760
5	#4 EXV Pos#3=xxx		0-760
6	#5 Output 4=Off	Off	On-Off
7	#6 Output 5=Off	Off	On-Off
8	#7 Output 6=Off	Off	On-Off
9	#8 Output 7=Off	Off	On-Off
10	#9 Output 8=Off	Off	On-Off
11	#10 Output 9=Off	Off	On-Off
12	#11 Output 10=Off	Off	On-Off
13	#12 Output 11=Off	Off	On-Off
14	#13 Output 12=Off	Off	On-Off
15	#14 Output 13=Off	Off	On-Off
16	#15 Output 14=Off	Off	On-Off
17	#16 Output 15=Off	Off	On-Off
18	#17 Output 16=Off	Off	On-Off
19	#18 Output 17=Off	Off	On-Off
20	#19 Output 18=Off	Off	On-Off
21	#20 Output 19=Off	Off	On-Off
22	#21 Output 20=Off	Off	On-Off
23	#22 Output 21=Off	Off	On-Off
24	#23 Output 22=Off	Off	On-Off
25	#24 Output 23=Off	Off	On-Off
26	#25 Output 24=Off	Off	On-Off
27	#26 Output 25=Off	Off	On-Off
28	#27 Output 26=Off	Off	On-Off
29	#28 Output 27=Off	Off	On-Off
30	#29 DH1=00000000		Digital Input ( 0-Open ) ( 1-Closed )
31	#30 DH2=00000000		Digital Input ( 0-Open ) ( 1-Closed )
32	#31 DH3=00000000		Digital Input ( 0-Open ) ( 1-Closed )
33	#32 Al#5= x.xx Vdc		Actual Vdc Value

Menu 26a. Alarm spts — values for R-22 refrigerant

Screen	Display	Factory Set Point	Range
1	StpPumpDn =xxpsi (kPa)	34 (234)	2 - 54 (13-372)
2	FullPumpDown= No	No	No - yes
3	FreezStat= xxpsi (kPa)	54 (372)	20 - 60 (138-414)
4	FreezH2O= xx.x °F (°C)	36.0 (2.3)	0.0 - 40.0 (-17.5-4.5)
5	Hi Press = xxpsi (kPa)	380 (2622)	280 - 426 (1932-2939)

Note: ( ) indicates Centigrade values

Menu 26b. Alarm spts — values for 134a refrigerant

Screen	Display	Factory Set Point	Range
1	StpPumpDn =xxpsi (kPa)	14 (96)	2 - 22 (13-151)
2	FullPumpDown= No	No	No - yes
3	FreezStat= xxpsi (kPa)	26 (179)	4 - 26 (27-179)
4	FreezH2O= xx.x °F (°C)	36.0 (2.3)	0.0 - 40.0 (-17.5-4.5)
5	Hi Press = xxpsi (kPa)	276 (1904)	180 - 326 (1242-2249)

Note: ( ) indicates Centigrade values

Menu 27. Misc setup

Screen	Display	Factory Set Point	Range
1	Unit Type= ALS205		
	ALS220		
	ALS235		
	ALS250		
	ALS265		
	ALS280		
2	Units = English	English	English-Metric
3	SpeedTrol = No	No	No-Yes
4	Power = 60 hz	60	60-50
5	Port A Baud=xxxx	9600	9600-2400-1200
6	Pre-Alarm=Blink	Blink	Blink-Open-Closed
	Open		
	Closed		
7	Alarm=Closed	Closed	Closed-Blink(N/O)-Blink(N/C)
	Blink(N/O)		
	Blink(N/C)		
8	OAT Select=None	None	None-Lcl-Rmt
	Lcl		
	Rmt		
9	Amb Lockout= No	No	No-Yes
	Yes		
10	LvgEvpAdj= 0.0 °F(°C)		-0.8-0.8 (-0.4-0.5)
11	EntEvpAdj= 0.0 °F(°C)		-0.8-0.8 (-0.4-0.5)
12	#1EvpAdj= 0.0psi (kPa)		-2.0-2.0 (-13.8-13.8)
13	#2EvpAdj= 0.0psi (kPa)		-2.0-2.0 (-13.8-13.8)
14	#3EvpAdj= 0.0psi (kPa)		-2.0-2.0 (-13.8-13.8)
15	#1CndAdj= 0.0psi (kPa)		-2.0-2.0 (-13.8-13.8)
16	#2CndAdj= 0.0psi (kPa)		-2.0-2.0 (-13.8-13.8)
17	#3CndAdj= 0.0psi (kPa)		-2.0-2.0 (-13.8-13.8)
18	Refrigerant= R22		Not Changeable
19	IDENT = SC32U19A		Not Changeable

Menu 28. #1 curr alarm

Screen	Display
1	Current Alarm
2	@ 0:00 0/00/00
3	Evap = x.x psi (kPa)
4	Cond = x.x psi (kPa)
5	SuctLine=xxx.x °F(°C)
6	LiquisLn=xxx.x °F(°C)
7	Evap Lvg=xxx.x °F(°C)
8	OutsideA=xxx.x °F(°C)
9	Capacity= xxx%
10	Fan Stage = x

Menu 30. #3 curr alarm

Screen	Display
1	Current Alarm
2	@ 0:00 0/00/00
3	Evap = x.x psi (kPa)
4	Cond = x.x psi (kPa)
5	SuctLine=xxx.x °F(°C)
6	LiquisLn=xxx.x °F(°C)
7	Evap Lvg=xxx.x °F(°C)
8	OutsideA=xxx.x °F(°C)
9	Capacity= xxx%
10	Fan Stage = x

Menu 29. #2 curr alarm

Screen	Display
1	Current Alarm
2	@ 0:00 0/00/00
3	Evap = x.x psi (kPa)
4	Cond = x.x psi (kPa)
5	SuctLine=xxx.x °F(°C)
6	LiquisLn=xxx.x °F(°C)
7	Evap Lvg=xxx.x °F(°C)
8	OutsideA=xxx.x °F(°C)
9	Capacity= xxx%
10	Fan Stage = x

Menu 31. #1 prev alarm

Screen	Display
1	1 Current Alarm
2	1 x:xx x/xx/xx
3	2 Current Alarm
4	2 x:xx x/xx/xx
5	3 Current Alarm
6	3 x:xx x/xx/xx
7	4 Current Alarm
8	4 x:xx x/xx/xx
9	5 Current Alarm
10	5 x:xx x/xx/xx

*Menu 32. #2 prev alarm*

Screen	Display
1	1 Current Alarm
2	1 x:xx x/xx/xx
3	2 Current Alarm
4	2 x:xx x/xx/xx
5	3 Current Alarm
6	3 x:xx x/xx/xx
7	4 Current Alarm
8	4 x:xx x/xx/xx
9	5 Current Alarm
10	5 x:xx x/xx/xx

*Menu 33. #3 prev alarm*

Screen	Display
1	1 Current Alarm
2	1 x:xx x/xx/xx
3	2 Current Alarm
4	2 x:xx x/xx/xx
5	3 Current Alarm
6	3 x:xx x/xx/xx
7	4 Current Alarm
8	4 x:xx x/xx/xx
9	5 Current Alarm
10	5 x:xx x/xx/xx

**Menus for Four (4) Screw Compressors Units**

*Menu 1. Chiller status*

Screen	Display
1	OFF: Manual Mode
	System Sw
	Remote Comm
	Remote Sw
	Time Clock
	Alarm
	PumpDnSw's
	Starting
	WaitForLoad
	CoolStageDn
	CoolStageUp
	CoolStaging #
	Manual Cool
	2
3	Hold Stage min
4	Hi Loop Temp=

*Menu 3. Circ #2 status*

Screen	Display
1	OFF: SystemSw
	ManualMde
	Alarm
	PumpDwnSw
	CycleTime xx
	WaitFlooded
	waitFlodded xxx
	Ready
	PumpingDown
	Starting
	Pre-Purge
	Opened EXV
	LowAmbStart
	Cooling %Cap=xxx

*Menu 2. Circ #1 status*

Screen	Display
1	OFF: SystemSw
	ManualMde
	Alarm
	PumpDwnSw
	CycleTime xx
	WaitFlooded
	waitFlodded xxx
	Ready
	PumpingDown
	Starting
	Pre-Purge
	Opened EXV
	LowAmbStart
	Cooling %Cap=xxx

*Menu 4. Circ #3 status*

Screen	Display
1	OFF: SystemSw
	ManualMde
	Alarm
	PumpDwnSw
	CycleTime xx
	WaitFlooded
	waitFlodded xxx
	Ready
	PumpingDown
	Starting
	Pre-Purge
	Opened EXV
	LowAmbStart
	Cooling %Cap=xxx

*Menu 5. Circ #4 status*

Screen	Display
1	OFF: SystemSw
	ManualMde
	Alarm
	PumpDwnSw
	CycleTime xx
	WaitFlooded
	waitFlodded xxx
	Ready
	PumpingDown
	Starting
	Pre-Purge
	Opened EXV
	LowAmbStart
	Cooling %Cap=xxx

*Menu 6. Water temp's*

Screen	Display
1	Lvg Evap= xxx.x °F (°C)
	Short °F (°C)
	Open °F (°C)
2	Ent Evap= xxx.x °F (°C)
	Short °F (°C)
	Open °F (°C)
3	Ent Cond= xxx.x °F (°C)
	Short °F (°C)
	Open °F (°C)
4	Lvg Cond= xxx.x °F (°C)
	Short °F (°C)
	Open °F (°C)

*Menu 7. Circ #1 pres's*

Screen	Display
1	Evap= xxx.x psi(kPa) xx°F (°C)
	Evap 145 +psi(kPa) **°F (°C)
	Open N/A ** °F (°C)
	Short N/A **°F (°C)
2	Cond xxx.x psi (kPa) xxx°
	Cond 450+ psi (kPa) xxx°
	Open N/A ** °F (°C)
	Short N/A **°F (°C)
3	MinCondPr = 0#
4	MaxCondPr = 0#
5	EXV Position= xxx
6	Cond Fan Stage = x

*Menu 8. Circ #2 pres's*

Screen	Display
1	Evap= xxx.x psi(kPa) xx°F (°C)
	Evap 145 +psi(kPa) **°F (°C)
	Open N/A ** °F (°C)
	Short N/A **°F (°C)
2	Cond xxx.x psi (kPa) xxx°
	Cond 450+ psi (kPa) xxx°
	Open N/A ** °F (°C)
	Short N/A **°F (°C)
3	MinCondPr = 0#
4	MaxCondPr = 0#
5	EXV Position= xxx
6	Cond Fan Stage = x

*Menu 9. Circ #3 pres's*

Screen	Display
1	Evap= xxx.x psi(kPa) xx°F (°C)
	Evap 145 +psi(kPa) **°F (°C)
	Open N/A ** °F (°C)
	Short N/A **°F (°C)
2	Cond xxx.x psi (kPa) xxx°
	Cond 450+ psi (kPa) xxx°
	Open N/A ** °F (°C)
3	MinCondPr = 0#
4	MaxCondPr = 0#
5	EXV Position= xxx
6	Cond Fan Stage = x

*Menu 10. Circ #4 pres's*

Screen	Display
1	Evap= xxx.x psi(kPa) xx°F (°C)
	Evap 145 +psi(kPa) **°F (°C)
	Open N/A ** °F (°C)
	Short N/A **°F (°C)
2	Cond xxx.x psi (kPa) xxx°
	Cond 450+ psi (kPa) xxx°
	Open N/A ** °F (°C)
3	MinCondPr = 0#
4	MaxCondPr = 0#
5	EXV Position= xxx
6	Cond Fan Stage = x

*Menu 11. Circ #1 temp's*

Screen	Display
1	Satur Evap=xxx°F (°C)
	N/A **°F (°C)
2	SuctLine = xxx.x°F (°C)
	Open °F (°C)
3	Short°F (°C)
	Super Ht =xxx.x°F (°C)
4	N/A ** °F (°C)
	Satur Cond = xxx°F (°C)
5	N/A **°F (°C)
	Liquid Ln = xxx.x°F (°C)
6	N/A ** °F (°C)
	SubCoolg= xxx.x°F (°C)
7	N/A ** °F (°C)
	Dscharge=xxx.x°F (°C)
	Open °F (°C)
	Short °F (°C)

*Menu 12. Circ #2 temp's*

Screen	Display
1	Satur Evap=xxx°F (°C)
	N/A **°F (°C)
2	SuctLine = xxx.x°F (°C)
	Open °F (°C)
3	Short°F (°C)
	Super Ht =xxx.x°F (°C)
4	N/A ** °F (°C)
	Satur Cond = xxx°F (°C)
5	N/A **°F (°C)
	Liquid Ln = xxx.x°F (°C)
6	N/A ** °F (°C)
	SubCoolg= xxx.x°F (°C)
7	N/A ** °F (°C)
	Dscharge=xxx.x°F (°C)
	Open °F (°C)
	Short °F (°C)

*Menu 13. Circ #3 temp's*

Screen	Display
1	Satur Evap=xxx°F (°C)
	N/A **°F (°C)
2	SuctLine = xxx.x°F (°C)
	Open °F (°C)
	Short°F (°C)
3	Super Ht =xxx.x°F (°C)
	N/A ** °F (°C)
4	Satur Cond = xxx°F (°C)
	N/A **°F (°C)
5	Liquid Ln = xxx.x°F (°C)
	N/A ** °F (°C)
6	SubCoolg= xxx.x°F (°C)
	N/A ** °F (°C)
7	Dscharge=xxx.x°F (°C)
	Open °F (°C)
	Short °F (°C)

*Menu 14. Circ #4 temp's*

Screen	Display
1	Satur Evap=xxx°F (°C)
	N/A **°F (°C)
2	SuctLine = xxx.x°F (°C)
	Open °F (°C)
	Short°F (°C)
3	Super Ht =xxx.x°F (°C)
	N/A ** °F (°C)
4	Satur Cond = xxx°F (°C)
	N/A **°F (°C)
5	Liquid Ln = xxx.x°F (°C)
	N/A ** °F (°C)
6	SubCoolg= xxx.x°F (°C)
	N/A ** °F (°C)
7	Dscharge=xxx.x°F (°C)
	Open °F (°C)
	Short °F (°C)

*Menu 15. Chiller amps*

Screen	Display
1	#1&3 PctRLA=xxx%
	N/A %
2	#2&4 PctRLA=xxx%
	N/A %

*Menu 16. Comp run hours*

Screen	Display
1	#1Total=xxxxxx
2	#2Total=xxxxxx
3	#3Total=xxxxxx
4	#4Total=xxxxxx
5	#1 @ 25%=xxxxxx
6	#1 @ 50%=xxxxxx
7	#1 @ 75%=xxxxxx
8	#1 @100%=xxxxxx
9	#2 @ 25%=xxxxxx
10	#2 @ 50%=xxxxxx
11	#2 @ 75%=xxxxxx
12	#2 @100%=xxxxxx
13	#3 @ 25%=xxxxxx
14	#3 @ 50%=xxxxxx
15	#3 @ 75%=xxxxxx
16	#3 @100%=xxxxxx
17	#4 @ 25%=xxxxxx
18	#4 @ 50%=xxxxxx
19	#4 @ 75%=xxxxxx
20	#4 @100%=xxxxxx

*Menu 17. Compr starts*

Screen	Display
1	#1 Total=xxxxxx
2	#2 Total=xxxxxx
3	#3 Total=xxxxxx
4	#4 Total=xxxxxx

*Menu 18. Air temp*

Screen	Display
1	OutDoor = xxx.x°F(°C)

*Menu 19. Control mode*

Screen	Display	Factory Set Point	Range
1	Manual Unit Off	Manual Unit Off	
	Automatic		
	Manual Staging		
	Service Testing		
2	Manual Stage=xx	0	1-16
3	Circ 1 Mode=Auto	Auto	Auto-Off
4	Circ 2 Mode=Auto	Auto	Auto-Off
5	Circ 3 Mode=Auto	Auto	Auto-Off
6	Circ 4Mode=Auto	Auto	Auto-Off

*Menu 20a. Lvg evap spts — values for R-22 refrigerant*

Screen	Display	Factory Set Point	Range
1	Actv Spt=xxx.x °F (°C)		Not Changeable
2	Lvg Evap=xxx.x °F (°C)	44 (6.7)	10-80 (-12.2-26.7)
3	CntrlBand x.x °F (°C)	3.0 (1.6)	1.0-5.0 (0.5-2.7)
4	StartUpD-T= x.x °F (°C)	3.0 (1.6)	1.0-5.0 (0.5-2.7)
5	ShutDn D-T= x.x °F (°C)	1.5 (0.8)	0.0-3.0 (0.0-1.6)
6	MaxPullDn= x.x °F (°C)	0.5 (0.2)	0.1-1.0 (0.0-0.5)
7	ResetOpt=None	None	
	Return		
	4-40 Ma		
	Network		
	Ice		
8	ResetSig= xx.xma		Not Changeable
9	MaxChWRst=xx.x °F (°C)	10.0 (5.5)	0.0-45.0 (0.0-25.0)
10	ReturnSpt= xx.x °F (°C)	54.0 (12.3)	15.0-80.0 (-9.4-26.7)
11	OatBegRst= xx.x °F (°C)	75.0 (23.9)	0.0-90.0 ([-17.8]-32.2)
12	OatMaxRst= xx.x °F (°C)	60.0 (15.5)	0.0-90.0 ([-17.8]-32.2)
13	HiChWTmp= xxx.x °F (°C)	60.0 (15.5)	20.0-90.0 (-6.6-32.2)
14	Amb Lock= xxx.x °F (°C)	30.0 (-1.1)	0.0-90.0 (-17.8-32.2)

**Note:** [ ] the minus sign is not displayed with three digit numbers ( ) indicates Centigrade values.

*Menu 20b. Lvg evap spts — values for 134a refrigerant*

Screen	Display	Factory Set Point	Range
1	Actv Spt=xxx.x °F (°C)		Not Changeable
2	Lvg Evap=xxx.x °F (°C)	44 (6.7)	10-80 (-6.6-26.7)
3	CntrlBand x.x °F (°C)	3.0 (1.6)	1.0-5.0 (0.5-2.7)
4	StartUpD-T= x.x °F (°C)	3.0 (1.6)	1.0-5.0 (0.5-2.7)
5	ShutDn D-T= x.x °F (°C)	1.5 (0.8)	0.0-3.0 (0.0-1.6)
6	MaxPullDn= x.x °F (°C)	0.5 (0.2)	0.1-1.0 (0.0-0.5)
7	ResetOpt=None	None	
	Return		
	4-40 Ma		
	Network		
	Ice		
8	ResetSig= xx.xma		Not Changeable
9	MaxChWRst=xx.x °F (°C)	10.0 (5.5)	0.0-45.0 (0.0-25.0)
10	ReturnSpt= xx.x °F (°C)	54.0 (12.3)	15.0-80.0 (-9.4-26.7)
11	OaTBegRst= xx.x °F (°C)	75.0 (23.9)	0.0-90.0 (-3.9-32.2)
12	OatMaxRst= xx.x °F (°C)	60.0 (15.5)	0.0-90.0 ([-17.8]-32.2)
13	HiChWTmp= xxx.x °F (°C)	60.0 (15.5)	20.0-90.0 (-6.6-32.2)
14	Amb Lock= xxx.x °F (°C)	30.0 (-1.1)	0.0-90.0 (-17.8-32.2)

**Note:** [ ] the minus sign is not displayed with three digit numbers ( ) indicates Centigrade values.

*Menu 21. Soft load spts*

Screen	Display	Factory Set Point	Range
1	Time Left= xxmin		
2	SoftLoad= xx min	20	0-254
3	SoftLdMaxStg= x	7	1-8
4	LoadDelay= xxsec	15	0-254

*Menu 22. Compressor spt*

Screen	Display	Factory Set Point	Range
1	Lead/=Auto	Auto	
	1->2->3->4		
	1->3->2->4		
	2->1->4->3		
	2->4->1->3		
	3->4->1->2		
	3->1->4->2		
	4->3->2->1		
4->2->3->1			
2	InterStg= xxx sec	210	60-480
3	MinST-ST=xx min	15	5-40
4	MinSP-ST xx min	5	3-30

*Menu 23a. Head pres spt — values for R-22 refrigerant*

Screen	Display	Factory Set Point	Range
1	MinLift 25%=xxx	70 (483)	60-100 (414-690)
2	MinLift 50%=xxx	80 (552)	70-100 (483-690)
3	MinLift100%=xxx	140 (966)	100-140 (690-966)
4	DeadBandMult= x.x	1.0	.8-1.3
5	StageUpErr= xxx	400 (2760)	300-990 (2070-6830)
6	StageDnErr = xxx	100 (690)	50-400 (340-2760)

**Note:** ( ) indicates Centigrade values

*Menu 23b. Head pres spt — values for 134a refrigerant*

Screen	Display	Factory Set Point	Range
1	MinLift 25%=xxx	50 (345)	40-60 (276-414)
2	MinLift 50%=xxx	56 (386)	50-80 (345-552)
3	MinLift100%=xxx	90 (621)	80-122 (552-841)
4	DeadBandMult= x.x	1.0	.8-1.3
5	StageUpErr= xxx	400 (2760)	300-990 (2070-6830)
6	StageDnErr = xxx	100 (690)	50-400 (340-2760)

**Note:** ( ) indicates Centigrade values

*Menu 24. Demand limits*

Screen	Display	Factory Set Point	Range
1	Demand Lim= xstg	3	Not Changeable at this screen
2	DemandSg= xx.x ma	Actual Value	Indicates the Magnitude of the Demand Limit Signal

*Menu 25. Time/date*

Screen	Display	Factory Set Point	Range
1	Time= xx:xx:xx		Actual Time
2	Mon xx/xx/xx		Actual Day and Date

*Menu 26. Schedule*

Screen	Display	Factory Set Point	Range
1	Override= xx.xx hr	0.00 Hr	00:00-63.50
2	NMPSchedule= N/A	N/A	1-32
3	Sun 00:00-23:59	00:00-23:59	00:00-23:59
4	Mon 00:00-23:59	00:00-23:59	00:00-23:59
5	Tue 00:00-23:59	00:00-23:59	00:00-23:59
6	Wed 00:00-23:59	00:00-23:59	00:00-23:59
7	Thu 00:00-23:59	00:00-23:59	00:00-23:59
8	Fri 00:00-23:59	00:00-23:59	00:00-23:59
9	Sat 00:00-23:59	00:00-23:59	00:00-23:59
10	Hol 00:00-23:59	00:00-23:59	00:00-23:59

Menu 27. Holiday date

Screen	Display	Factory Set Point	Range
1	#1 Date = N/A 0	N/A 0	Jan - Dec 1 - 31
2	#1 Dur = 0 Day(s)	0	0 - 31
3	#2 Date = N/A 0	N/A 0	Jan - Dec 1 - 31
4	#2 Dur = 0 Day(s)	0	0 - 31
5	#3 Date = N/A 0	N/A 0	Jan - Dec 1 - 31
6	#3 Dur = 0 Day(s)	0	0 - 31
7	#4 Date = N/A 0	N/A 0	Jan - Dec 1 - 31
8	#4 Dur = 0 Day(s)	0	0 - 31
9	#5 Date = N/A 0	N/A 0	Jan - Dec 1 - 31
10	#5 Dur = 0 Day(s)	0	0 - 31
11	#6 Date = N/A 0	N/A 0	Jan - Dec 1 - 31
12	#6 Dur = 0 Day(s)	0	0 - 31
13	#7 Date = N/A 0	N/A 0	Jan - Dec 1 - 31
14	#7 Dur = 0 Day(s)	0	0 - 31
15	#8 Date = N/A 0	N/A 0	Jan - Dec 1 - 31
16	#8 Dur = 0 Day(s)	0	0 - 31
17	#9 Date = N/A 0	N/A 0	Jan - Dec 1 - 31
18	#9 Dur = 0 Day(s)	0	0 - 31
19	#10 Date = N/A 0	N/A 0	Jan - Dec 1 - 31
20	#10 Dur = 0 Day(s)	0	0 - 31
21	#11 Date = N/A 0	N/A 0	Jan - Dec 1 - 31
22	#11 Dur = 0 Day(s)	0	0 - 31
23	#12 Date = N/A 0	N/A 0	Jan - Dec 1 - 31
24	#12 Dur = 0 Day(s)	0	0 - 31
25	#13 Date = N/A 0	N/A 0	Jan - Dec 1 - 31
26	#13 Dur = 0 Day(s)	0	0 - 31
27	#14 Date = N/A 0	N/A 0	Jan - Dec 1 - 31
28	#14 Dur = 0 Day(s)	0	0 - 31



Menu 28. Service test

Screen	Display	Factory Set Point	Range
1	#0 Output 0=Off	Off	On-Off
2	#1 Output 1=Off	Off	On-Off
3	#2 EXV Pos#1=xxx		0-760
4	#3 EXV Pos#2=xxx		0-760
5	#4 EXV Pos#3=xxx		0-760
6	#5 EXV Pos#4=xxx		0-760
7	#6 Output 4=Off	Off	On-Off
8	#7 Output 5=Off	Off	On-Off
9	#8 Output 6=Off	Off	On-Off
10	#9 Output 7=Off	Off	On-Off
11	#10 Output 8=Off	Off	On-Off
12	#11 Output 9=Off	Off	On-Off
13	#12 Output 10=Off	Off	On-Off
14	#13 Output 11=Off	Off	On-Off
15	#14 Output 12=Off	Off	On-Off
16	#15 Output 13=Off	Off	On-Off
17	#16 Output 14=Off	Off	On-Off
18	#17 Output 15=Off	Off	On-Off
19	#18 Output 16=Off	Off	On-Off
20	#19 Output 17=Off	Off	On-Off
21	#20 Output 18=Off	Off	On-Off
22	#21 Output 19=Off	Off	On-Off
23	#22 Output 20=Off	Off	On-Off
24	#23 Output 21=Off	Off	On-Off
25	#24 Output 22=Off	Off	On-Off
26	#25 Output 23=Off	Off	On-Off
27	#26 Output 24=Off	Off	On-Off
28	#27 Output 25=Off	Off	On-Off
29	#28 Output 26=Off	Off	On-Off
30	#29 Output 27=Off	Off	On-Off
31	#30 Output 28=Off	Off	On-Off
32	#31 Output 29=Off	Off	On-Off
33	#32 Output 31=Off	Off	On-Off
34	#33 Output 32=Off	Off	On-Off
35	#34 Output 33=Off	Off	On-Off
36	#35 Output 34=Off	Off	On-Off
37	#36 Output 35=Off	Off	On-Off
38	#37 Output 36=Off	Off	On-Off
39	#38 Output 37=Off	Off	On-Off
40	#39 Output 38=Off	Off	On-Off
41	#40 DH1=00000000		Digital Input ( 0-Open ) ( 1-Closed )
42	#41 DH2=00000000		Digital Input ( 0-Open ) ( 1-Closed )
43	#42 DH3=00000000		Digital Input ( 0-Open ) ( 1-Closed )
44	#43 DH4=00000000		Digital Input ( 0-Open ) ( 1-Closed )
45	#32 Al#5= x.xx Vdc		Actual Vdc Value

Menu 29a. Alarm spts – values for R-22 refrigerant

Screen	Display	Factory Set Point	Range
1	StpPumpDn =xxpsi (kPa)	34 (234)	2-54 (13-372)
2	FullPumpDown= No	No	No-yes
3	FreezStat= xxpsi (kPa)	54 (372)	20-60 (138-414)
4	FreezH2O= xx.x °F (°C)	36.0 (2.3)	0.0-40.0 (-17.5-4.5)
5	Hi Press = xxpsi (kPa)	380 (2622)	280-426 (1932-2939)

Note: ( ) indicates Centigrade values

Menu 29b. Alarm spts – values for 134a refrigerant

Screen	Display	Factory Set Point	Range
1	StpPumpDn =xxpsi (kPa)	14 (96)	2-22 (13-151)
2	FullPumpDown= No	No	No-yes
3	FreezStat= xxpsi (kPa)	26 (179)	4-26 (27-179)
4	FreezH2O= xx.x °F (°C)	36.0 (2.3)	0.0 - 40.0 (-17.5-4.5)
5	Hi Press = xxpsi (kPa)	276 (1904)	180 - 326 (1242-2249)

Note: ( ) indicates Centigrade values

Menu 30. Misc setup

Screen	Display	Factory Set Point	Range
1	Unit Type = ALS300		
	ALS315		
	ALS330		
	ALS340		
	ALS360		
	ALS370		
2	Units = English	English	English-Metric
3	SpeedTrol = No	No	No-Yes
4	Power = 60 hz	60	60-50
5	Port A Baud=xxxx	9600	9600-2400-1200
6	Pre-Alarm=Blink	Blink	Blink-Open-Closed
	Open		
	Closed		
7	Alarm=Closed	Closed	Closed-Blink(N/O)-Blink(N/C)
	Blink(N/O)		
	Blink(N/C)		
8	OAT Select=None	None	None-Lcl-Rmt
	Lcl		
	Rmt		
9	Amb Lockout= No	No	No-Yes
	Yes		
10	LvgEvpAdj= 0.0 °F(°C)		-0.8-0.8 (-0.4-0.5)
11	EntEvpAdj= 0.0 °F(°C)		-0.8-0.8 (-0.4-0.5)
12	#1EvpAdj= 0.0psi (kPa)		-2.0-2.0 (-13.8-13.8)
13	#2EvpAdj= 0.0psi (kPa)		-2.0-2.0 (-13.8-13.8)
14	#3EvpAdj= 0.0psi (kPa)		-2.0-2.0 (-13.8-13.8)
15	#4EvpAdj=0.0psi (kPa)		-2.0-2.0 (-13.8-13.8)
16	#1CndAdj= 0.0psi (kPa)		-2.0-2.0 (-13.8-13.8)
17	#2CndAdj= 0.0psi (kPa)		-2.0-2.0 (-13.8-13.8)
18	#3CndAdj= 0.0psi (kPa)		-2.0-2.0 (-13.8-13.8)
19	#4CndAdj=0.0psi (kPa)		-2.0-2.0 (-13.8-13.8)
20	Refrigerant= R22		Not Changeable
21	IDENT = SC4XX19A		Not Changeable

Menu 31. #1 curr alarm

Screen	Display
1	Current Alarm
2	@ 0:00 0/00/00
3	Evap = x.x psi (kPa)
4	Cond = x.x psi (kPa)
5	SuctLine=xxx.x °F(°C)
6	LiquisLn=xxx.x °F(°C)
7	Evap Lvg=xxx.x °F(°C)
8	OutsideA=xxx.x °F(°C)
9	Capacity= xxx%
10	Fan Stage = x

Menu 33. #3 curr alarm

Screen	Display
1	Current Alarm
2	@ 0:00 0/00/00
3	Evap = x.x psi (kPa)
4	Cond = x.x psi (kPa)
5	SuctLine=xxx.x °F(°C)
6	LiquisLn=xxx.x °F(°C)
7	Evap Lvg=xxx.x °F(°C)
8	OutsideA=xxx.x °F(°C)
9	Capacity= xxx%
10	Fan Stage = x

Menu 32. #2 curr alarm

Screen	Display
1	Current Alarm
2	@ 0:00 0/00/00
3	Evap = x.x psi (kPa)
4	Cond = x.x psi (kPa)
5	SuctLine=xxx.x °F(°C)
6	LiquisLn=xxx.x °F(°C)
7	Evap Lvg=xxx.x °F(°C)
8	OutsideA=xxx.x °F(°C)
9	Capacity= xxx%
10	Fan Stage = x

Menu 34. #4 curr alarm

Screen	Display
1	Current Alarm
2	@ 0:00 0/00/00
3	Evap = x.x psi (kPa)
4	Cond = x.x psi (kPa)
5	SuctLine=xxx.x °F(°C)
6	LiquisLn=xxx.x °F(°C)
7	Evap Lvg=xxx.x °F(°C)
8	OutsideA=xxx.x °F(°C)
9	Capacity= xxx%
10	Fan Stage = x

*Menu 35. #1 prev alarm*

Screen	Display
1	1 Current Alarm
2	1 x:xx x/xx/xx
3	2 Current Alarm
4	2 x:xx x/xx/xx
5	3 Current Alarm
6	3 x:xx x/xx/xx
7	4 Current Alarm
8	4 x:xx x/xx/xx
9	5 Current Alarm
10	5 x:xx x/xx/xx

*Menu 36. #2 prev alarm*

Screen	Display
1	1 Current Alarm
2	1 x:xx x/xx/xx
3	2 Current Alarm
4	2 x:xx x/xx/xx
5	3 Current Alarm
6	3 x:xx x/xx/xx
7	4 Current Alarm
8	4 x:xx x/xx/xx
9	5 Current Alarm
10	5 x:xx x/xx/xx

*Menu 37. #3 prev alarm*

Screen	Display
1	1 Current Alarm
2	1 x:xx x/xx/xx
3	2 Current Alarm
4	2 x:xx x/xx/xx
5	3 Current Alarm
6	3 x:xx x/xx/xx
7	4 Current Alarm
8	4 x:xx x/xx/xx
9	5 Current Alarm
10	5 x:xx x/xx/xx

*Menu 38. #4 prev alarm*

Screen	Display
1	1 Current Alarm
2	1 x:xx x/xx/xx
3	2 Current Alarm
4	2 x:xx x/xx/xx
5	3 Current Alarm
6	3 x:xx x/xx/xx
7	4 Current Alarm
8	4 x:xx x/xx/xx
9	5 Current Alarm
10	5 x:xx x/xx/xx

# Schematics and Drawings

## ALS PFS Wiring Diagrams

Table 15.

Unit	Control Cabinet Layout	Wiring Legend	Unit Control	Stage Output	MicroTech Schematic	Field Wiring
ALS 125A - 204A	717449-01	704352C-01	716995D-01	716996D-01	716997D-01	719740C-01
PFS 140A - 200A	719836-01	719833C-01	716998D-01	716999D-01	718099D-01	719835C-01
ALS 205A - 280A	717460-01	704352C-01	718507D-01	718508D-01	718509D-01	719740C-01
ALS 300A - 380A	719869-01	—	718640D-01	718641D-01	718642F-01	719740C-01

### Control Cabinet Layout – ALS 125A-204A

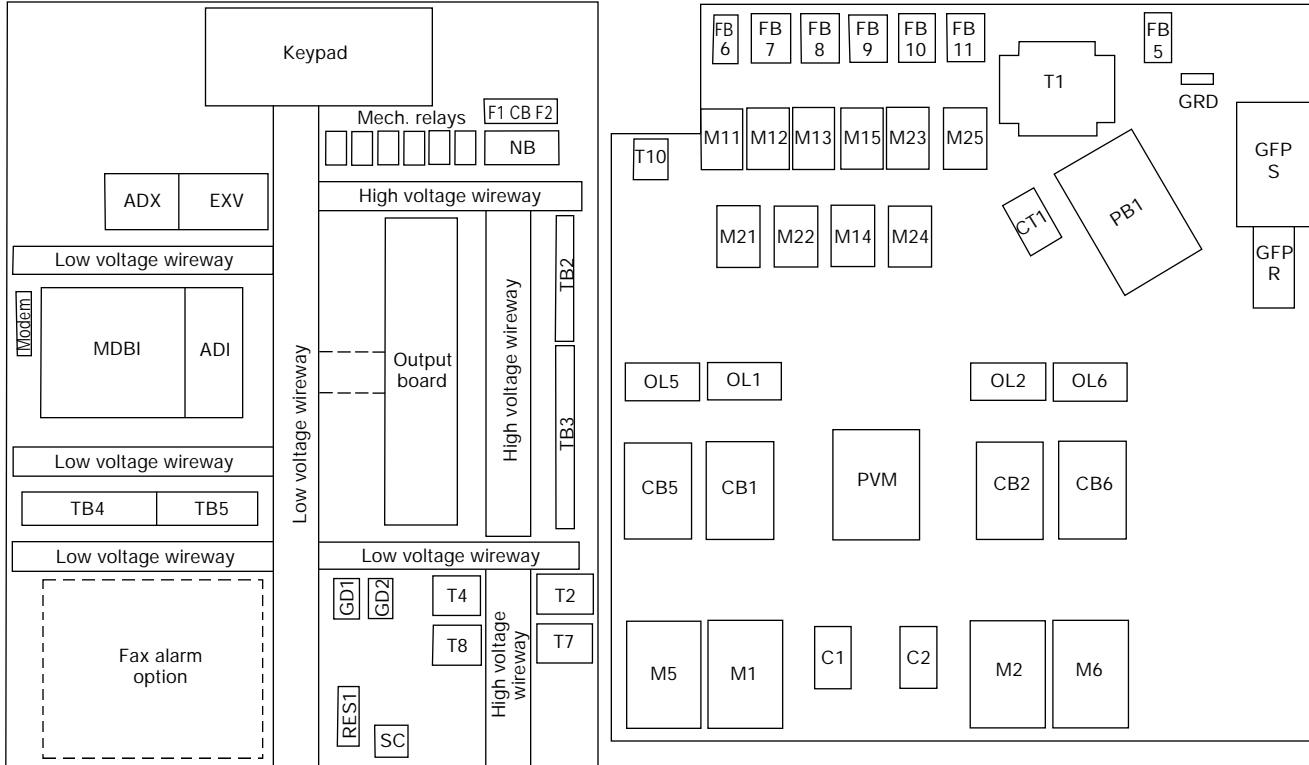





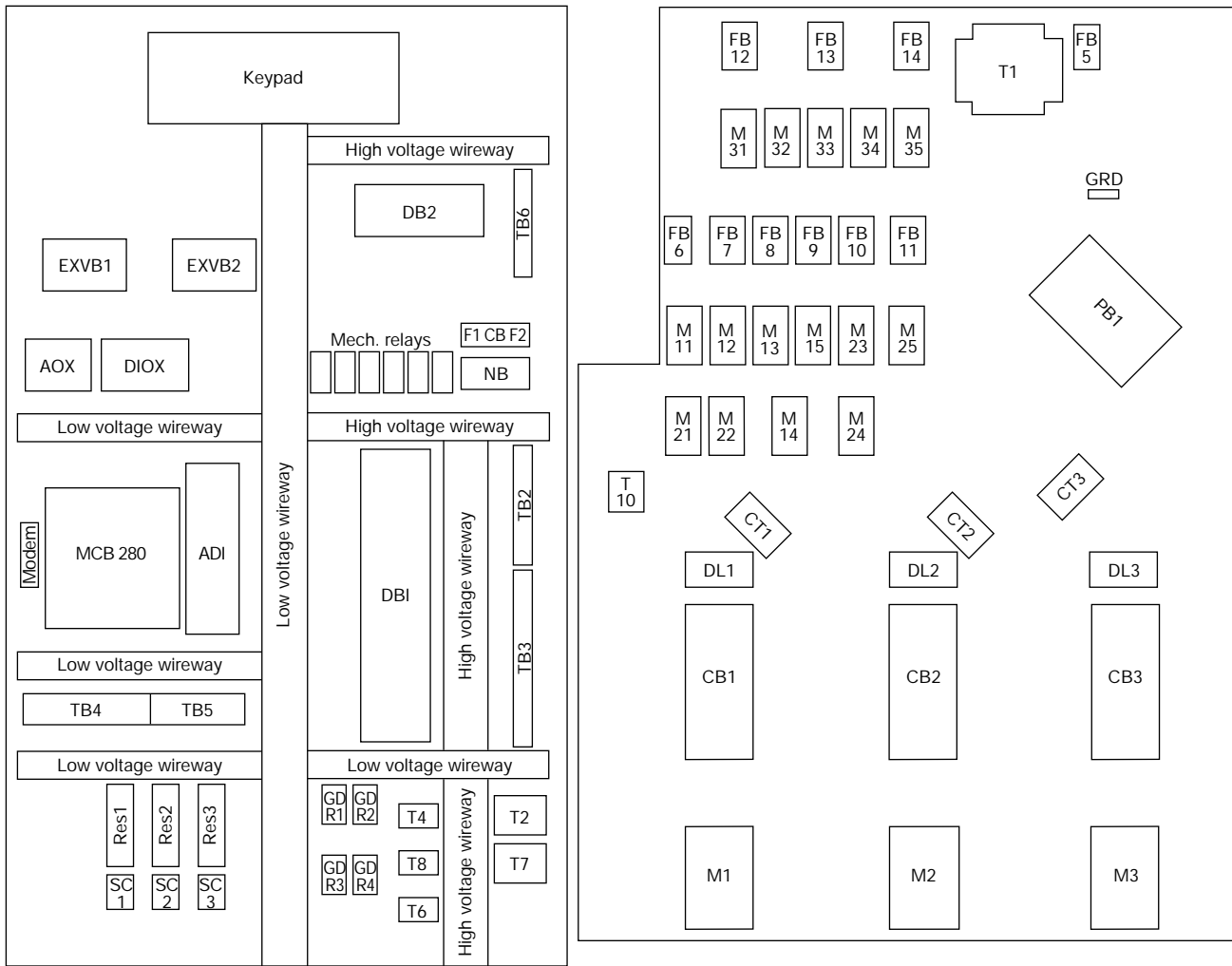









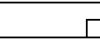

# Control Cabinet Layout – ALS 300A-380A



# Wiring legend – 0704352C-01

ALS Wiring Legend					
Label	Description	Standard Location	Label	Description	Standard Location
AB	ALARM BELL	BACK OR SIDE OF CTRL BOX	PSI-PS3	PUMPDOWN SWITCHES	CTRL BOX, SWITCH PANEL
ADI	ANALOG DIGITAL INPUT BOARD	CTRL BOX, CTRL PANEL	PVMI-PVM3	PHASE VOLTAGE MONITOR	CTRL BOX, POWER PANEL
AOX	ANALOG OUTPUT BOARD	CTRL BOX, CTRL PANEL	RES1,RES2	RESISTOR, CURRENT TRANSFORMER	CTRL BOX, POWER PANEL
CI-C3	SURGE CAPACITOR, COMPRESSOR	CTRL BOX, POWER PANEL	SI	SWITCH, MANUAL START/STOP	CTRL BOX, KEYPAD PANEL
CI,C2I	CAPACITOR, SPEEDTROL	INSIDE SPEEDTROL BOX	SCII,SC21,SC31	SPEED CONTROL	INSIDE SPEEDTROL BOX
CBI-CB7	CIRCUIT BREAKER (POWER)	CTRL BOX, POWER PANEL	SIG.CONV(SC)	SIGNAL CONVERTER	CTRL BOX, CTRL PANEL
CB9	CIRCUIT BREAKER (MICROTECH)	CTRL BOX, CTRL PANEL	SV1,SV2,SV7	SOLENOID VALVE, LIQ. LINES	ON LIQUID LINES
CBIO	CIRCUIT BREAKER (FAX ALARM)	CTRL BOX, CTRL PANEL	SV3,SV4,SV8	SOLENOID VALVE, LIQ. INJECTION	ON COMPR LIQ. INJ. LINE
CHW1	CHILLED WATER INTERLOCK	FIELD INSTALLED	SV5,SV6,SV9	SOLENOID VALVE, HG BYPASS	ON LINE TO HOT GAS VALVE
COMPR 1-3	COMPRESSORS1-3	ON BASE RAIL	T1	TRANSFORMER, MAIN CONTROL	CTRL BOX, POWER PANEL
CSII-CS33	COMPRESSOR SOLENOID	ON COMPRESSOR	T2, T5, T7	TRANSFORMER, 120 TO 24V CONTROL	CTRL BOX, CTRL PANEL
CTI,CT2	CURRENT TRANSFORMER	CTRL BOX, POWER PANEL	T3	TRANSFORMER, 575 TO 208-230V SPEEDTROL	CTRL BOX, CTRL PANEL
DS1,DS2	DISCONNECT SWITCH, MAIN	CTRL BOX, POWER PANEL	T4,T6	TRANSFORMER, 24 TO 18V CONTROL	CTRL BOX, CTRL PANEL
EXV (BRD)	ELECTRONIC EXPANSION VALVE BOARD	CTRL BOX, CTRL PANEL	TIO	TRANSFORMER, 208-240 TO 24V OR 460 TO 24V -SPEEDTROL	CTRL BOX, CTRL PANEL
F1	FUSE, CONTROL CIRCUIT	CTRL BOX, SWITCH PANEL	TB2	TERMINAL BLOCK, 120V FIELD	CTRL BOX, CTRL PANEL
F2	FUSE, COOLER HEATER	CTRL BOX, SWITCH PANEL	TB3	TERMINAL BLOCK, 120V	CTRL BOX, CTRL PANEL
FB5	FUSEBLOCK, CONTROL POWER	CTRL BOX, POWER PANEL	TB4-TB5	TERMINAL BLOCK, CONTROL 24V OR LESS	CTRL BOX, CTRL PANEL
FB6-FBI5	FUSEBLOCKS, FAN MOTORS	CTRL BOX, POWER PANEL	TBIO	TERMINAL BLOCK, FAX ALARM	CTRL BOX, CTRL PANEL
GDI-GD3	GUARDISTOR RELAY	CTRL BOX, CTRL PANEL	TD5-TD7	TIME DELAY, COMPR. REDUCED INRUSH	CTRL BOX, CTRL PANEL
GFP	GROUND FAULT PROTECTOR	CTRL BOX, POWER PANEL			
GRD,GND	GROUND	CTRL BOX, POWER PANEL			
HGR1-HGR2	HOT GAS RELAY	CTRL BOX, POWER PANEL			
HTRI-HTR3	COMPRESSOR HEATER	ON COMPRESSORS			
HTR5	HEATER, EVAPORATOR	WRAPPED AROUND EVAP.			
JI-JI3	JUMPERS (LEAD)	CTRLBOX, CTRLPANEL			
JB5	JUNCTION BOX, EVAP. HEATER	NEAR EVAP, ON BASE RAIL			
KEYPAD	KEYPAD SWITCH & DISPLAY	CTRL BOX, KEYPAD PANEL			
LPSI-LPS3	LIQUID PRESENCE SENSOR	ON COMPRESSOR			
MI-M7	CONTACTORS, COMPRESSOR	CTRLBOX, POWERPANEL			
MII-M37	CONTACTOR, FAN MOTORS	CTRL BOX, POWER PANEL			
MCB250	MICROTECH CONTROL BOARD-250	CTRL BOX, CTRL PANEL			
MHPRI-MHPR3	MECH. HIGH PRESSURE RELAY	CONTROL BOX, CTRL PANEL			
MJ	MECHANICAL JUMPER	CTRL BOX, CTRL PANEL			
MODEMI	MODEM, MICROTECH	CTRL BOX, CTRL PANEL			
MODEM2	MODEM, FAX	CTRL BOX, CTRL PANEL			
MPRI-MPR3	MOTOR PROTECTOR RELAY	CONTROL BOX, CTRL PANEL			
MTRII-MTR37	MOTORS, CONDENSER FANS	CONDENSER SECTION			
NB	NEUTRAL BLOCK	CTRL BOX, CTRL PANEL			
OB	OUTPUT BOARD, MICROTECH	CTRL BOX, CTRL PANEL			
OLI-OL7	OVERLOADS	CTRL BOX, POWER PANEL			
OSI-OS3	OIL SAFETY SWITCH	CTRL BOX, CTRL PANEL			
PBI-PB3	POWER BLOCK, MAIN	CTRL BOX, POWER PANEL			

## WIRING SYMBOLS

	POWER WIRING, FACTORY INSTALLED		CABLE-TWISTED, SHIELDED AND JACKETED PAIR
	POWER WIRING, FACTORY INSTALLED		OPTION BLOCK
	POWER WIRING, FACTORY INSTALLED		THERMISTOR
	CONTROL BOX TERMINAL, FIELD CONN. USAGE		DIODE
	CONTROL BOX TERMINAL, FACTORY USAGE		CAPACITOR
	UNIDENTIFIED COMPONENT TERMINAL		VARIATOR
	IDENTIFIED COMPONENT TERMINAL		
	WIRE NUT		
	MANUAL RESET, CONTROL		
	AUTOMATIC RESET, CONTROL		

# PFS Unit Control - 0716998D-01

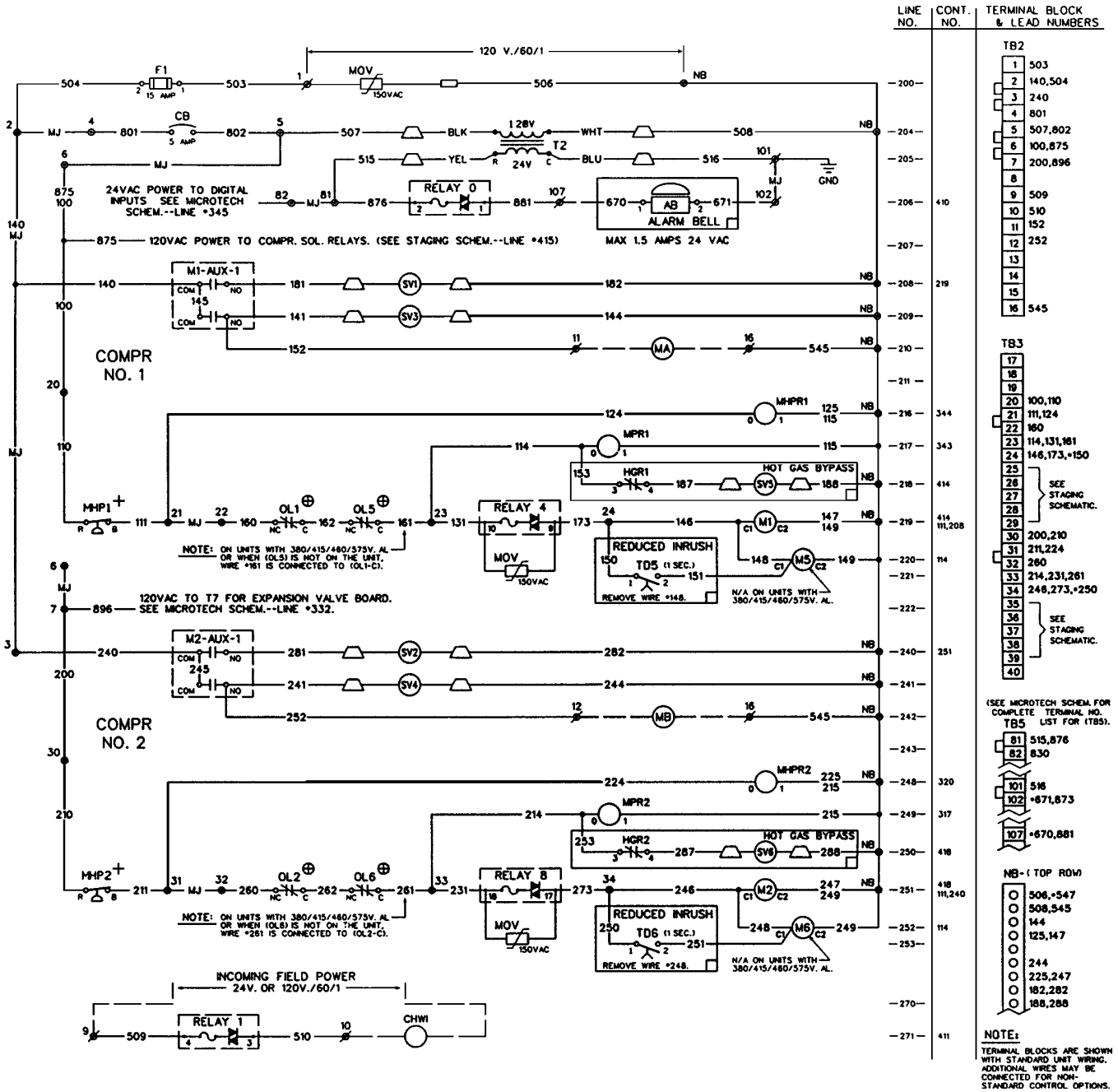

(SEE MICROTECH SCHEM FOR COMPLETE TERMINAL NO. LIST FOR (TBS).)

**TB2**  
 1 503  
 2 140,504  
 3 240  
 4 801  
 5 507,802  
 6 100,875  
 7 200,896  
 8  
 9 509  
 10 510  
 11 152  
 12 252  
 13  
 14  
 15  
 16 545

**TB3**  
 17  
 18  
 19  
 20 100,110  
 21 111,124  
 22 180  
 23 114,131,181  
 24 146,173,150  
 25  
 26 } SEE STAGING SCHEMATIC.  
 27  
 28  
 29 200,210  
 30 211,224  
 31 280  
 32 214,231,261  
 33 246,273,250  
 34  
 35  
 36 } SEE STAGING SCHEMATIC.  
 37  
 38  
 39  
 40

**TB5**  
 81 515,876  
 82 830  
 101 516  
 102 \*671,873  
 107 \*670,881

**NB - (TOP ROW)**  
 ○ 506,547  
 ○ 508,545  
 ○ 144  
 ○ 125,147  
 ○ 244  
 ○ 225,247  
 ○ 182,282  
 ○ 188,288

**NOTE:**  
 TERMINAL BLOCKS ARE SHOWN WITH STANDARD UNIT WIRING. ADDITIONAL WIRES MAY BE CONNECTED FOR NON-STANDARD CONTROL OPTIONS.



# PFS 8-Stage Output - 071699D-01

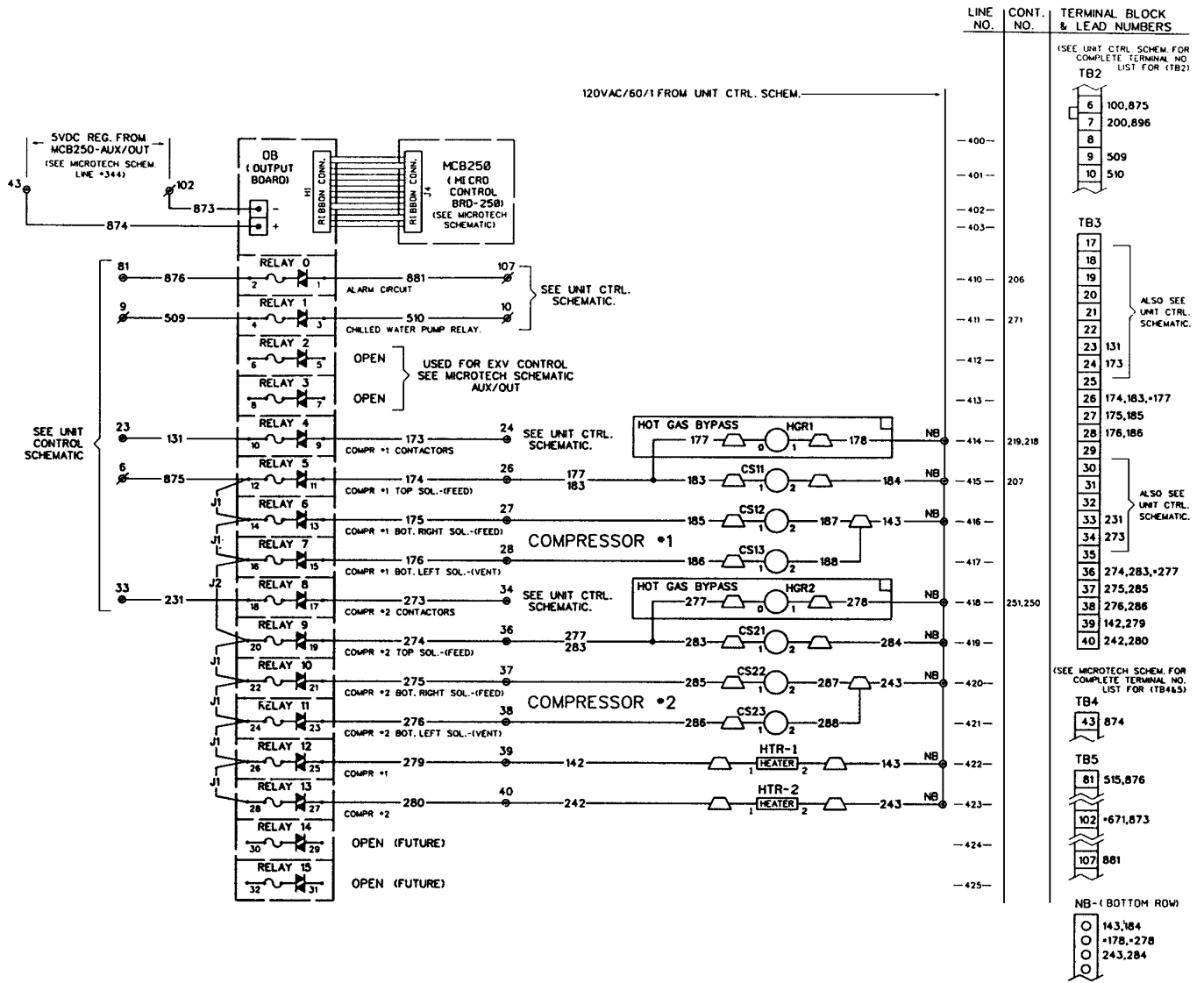

**NOTE:**  
 TERMINAL BLOCKS ARE SHOWN WITH STANDARD UNIT WIRING. ADDITIONAL WIRES MAY BE CONNECTED FOR NON-STANDARD CONTROL OPTIONS.

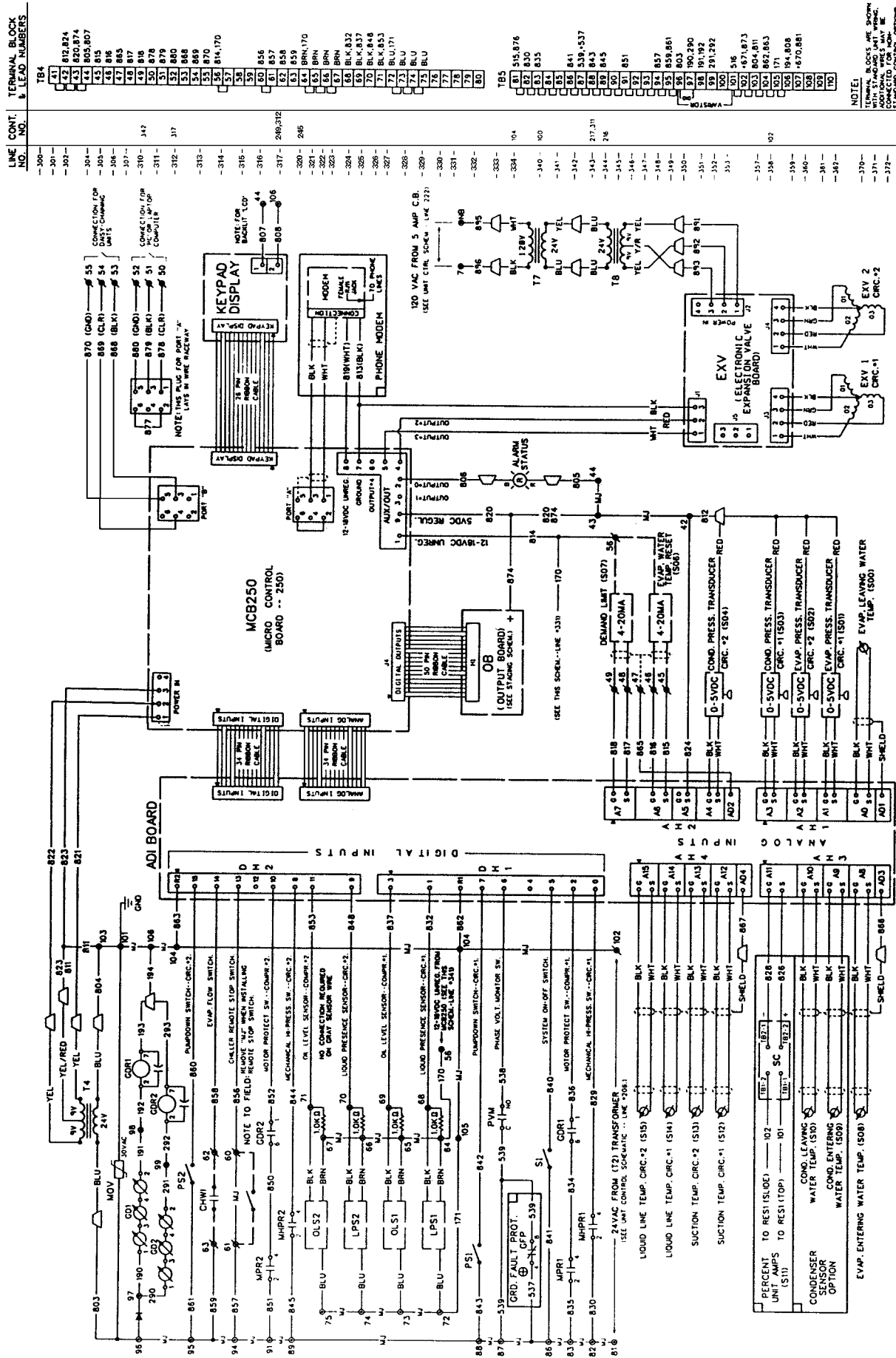

# ALS Unit Control - 0716995D-01

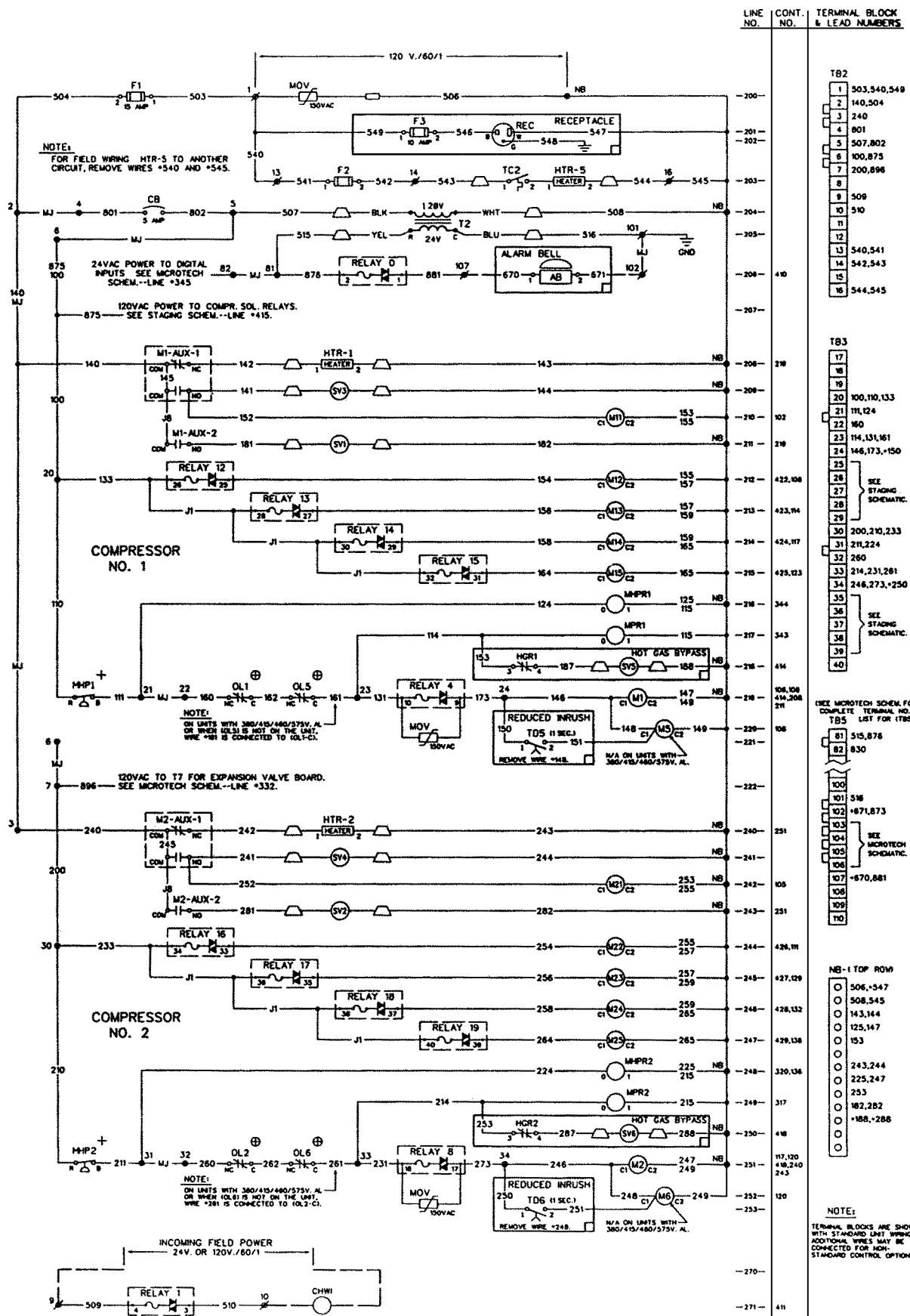

LINE NO.	CONT. NO.	TERMINAL BLOCK & LEAD NUMBERS
200		TB2
201		1 503,540,549
202		2 140,504
203		3 240
204		4 801
205		5 507,802
206		6 100,875
207		7 200,896
208		8
209		9 509
210		10 510
211		11
212		12
213		13 540,541
214		14 542,543
215		15
216		16 544,545
217		TB3
218		17
219		18
220		19
221		20 100,110,133
222		21 111,124
223		22 160
224		23 114,131,161
225		24 146,173,150
226		25
227		26 } SEE STAGING SCHEMATIC.
228		27
229		28
230		29 } SEE STAGING SCHEMATIC.
231		30 200,210,233
232		31 211,224
233		32 260
234		33 214,231,261
235		34 246,273,250
236		35
237		36 } SEE STAGING SCHEMATIC.
238		37
239		38
240		39
241		40
242		SEE MICROTECH SCHEM FOR COMPLETE UNIT WIRING. TB5 LIST FOR TB5.
243		81 515,876
244		82 830
245		100
246		101 516
247		102 #871,873
248		103
249		104 } SEE MICROTECH SCHEMATIC.
250		105
251		106
252		107 #670,881
253		108
254		109
255		110
256		NB-1 TOP ROW
257		○ 506,547
258		○ 508,545
259		○ 143,144
260		○ 125,147
261		○ 153
262		○ 243,244
263		○ 225,247
264		○ 253
265		○ 182,282
266		○ 188,288
267		○
268		○
269		○
270		117,120
271		418,240
272		243
273		120
274		252
275		253
276		270
277		411

# ALS 8-Stage Output - 0716996D-01

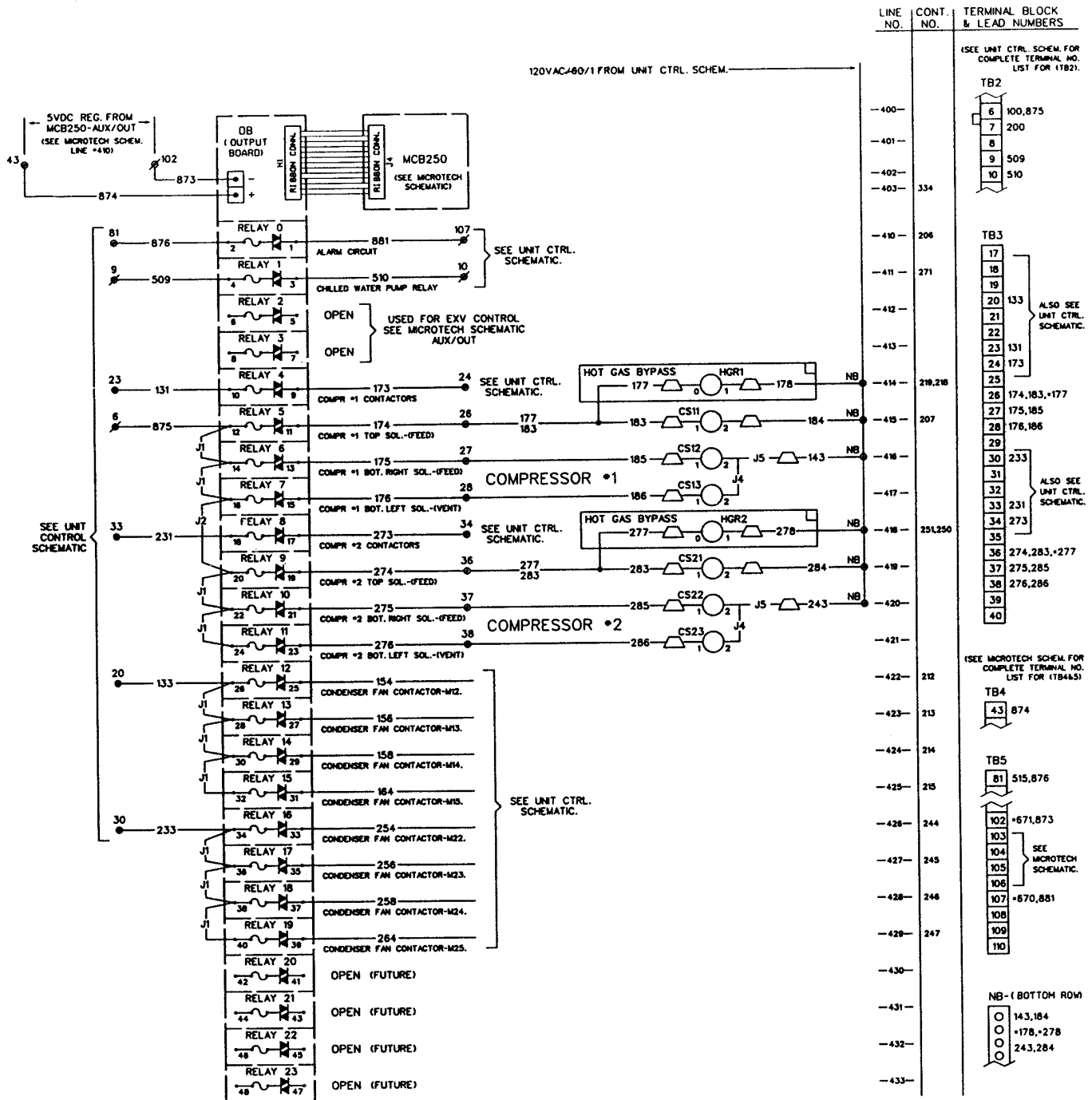

**NOTE:**  
 TERMINAL BLOCKS ARE SHOWN WITH STANDARD WIRING. ADDITIONAL WIRES MAY BE CONNECTED FOR NON-STANDARD CONTROL OPTIONS.

# ALS MicroTech - 2 Compressor Unit - 716997D-01

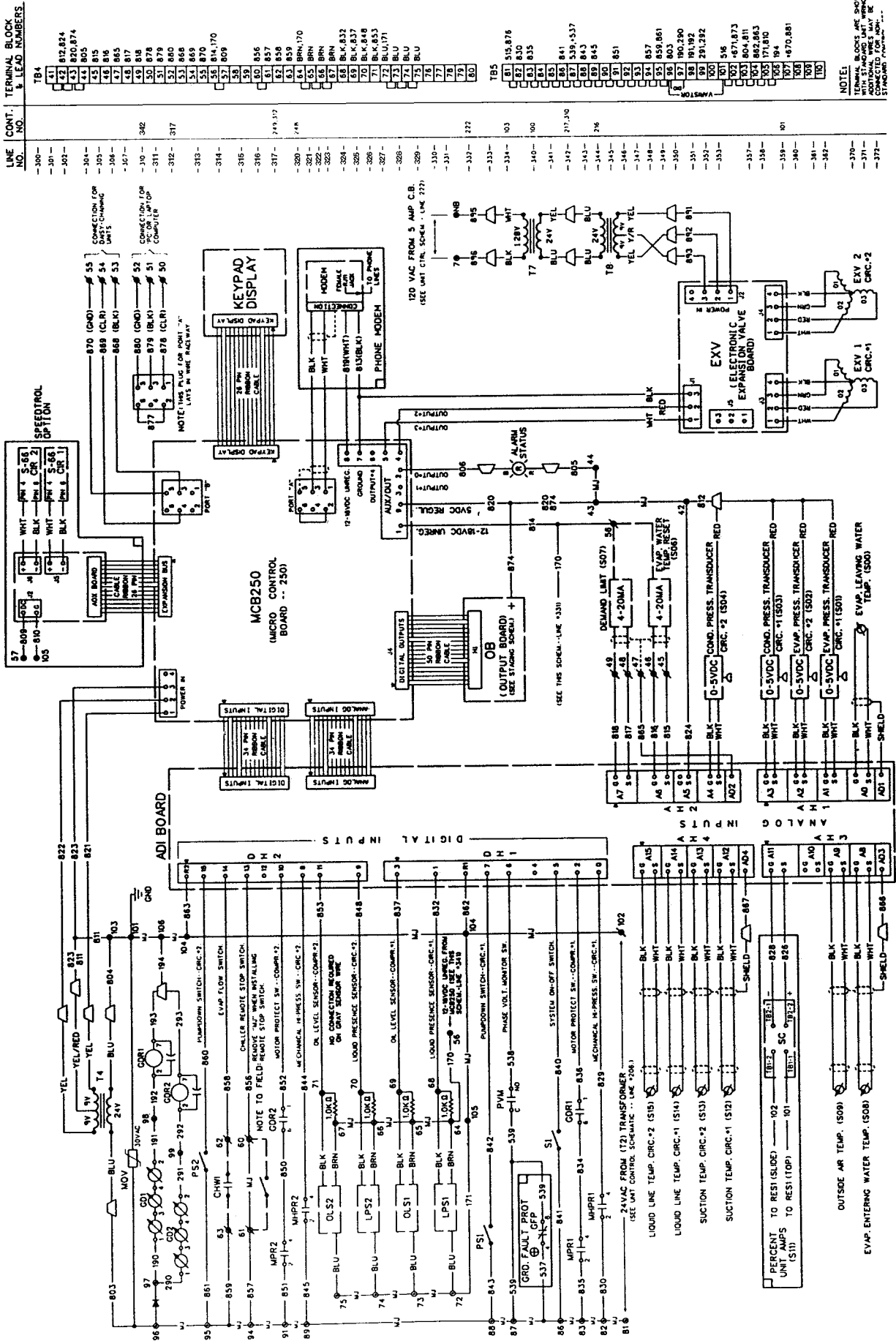

# ALS Field Wiring – 0719740C-01

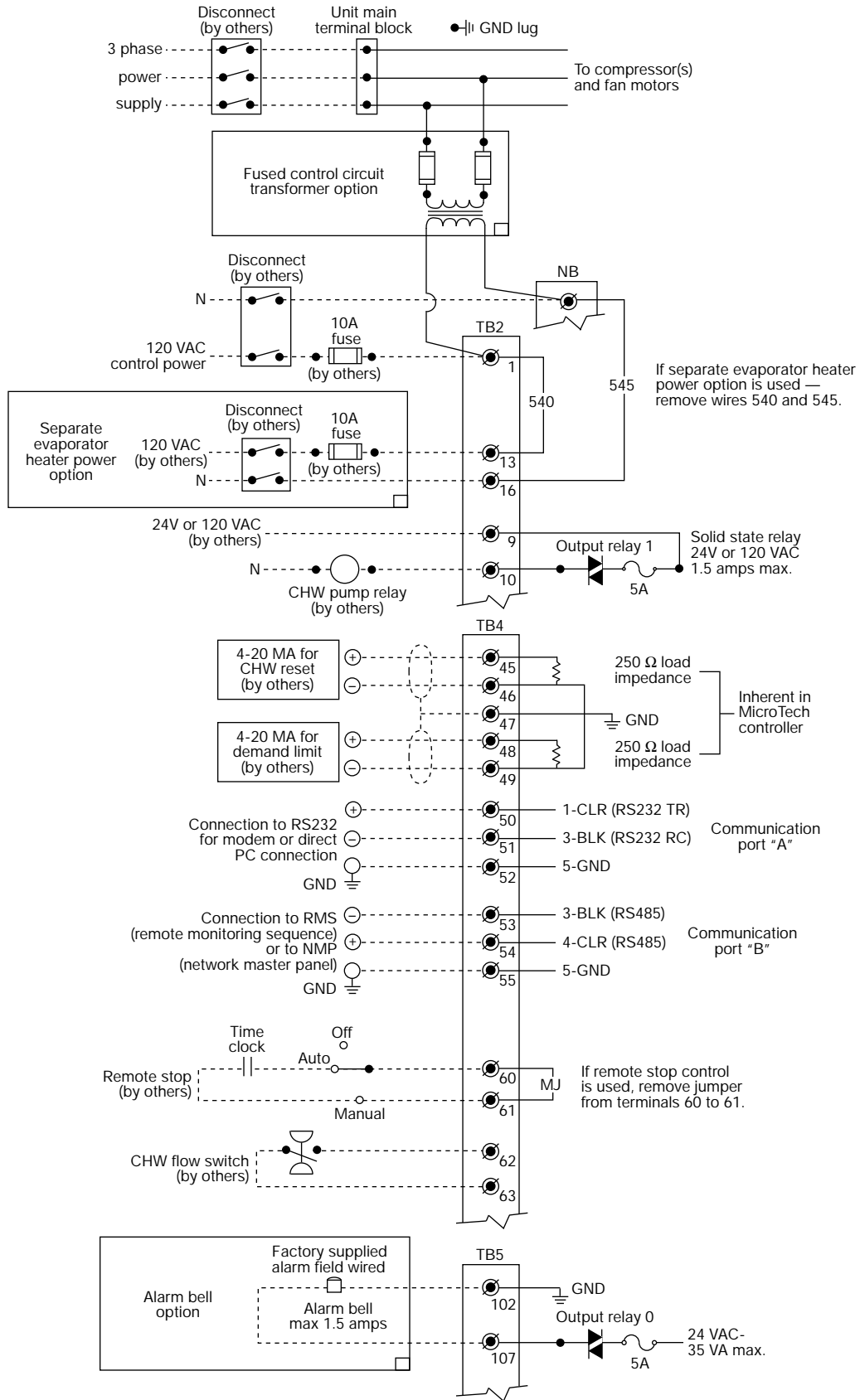

# PFS Field Wiring – 0719835C-01

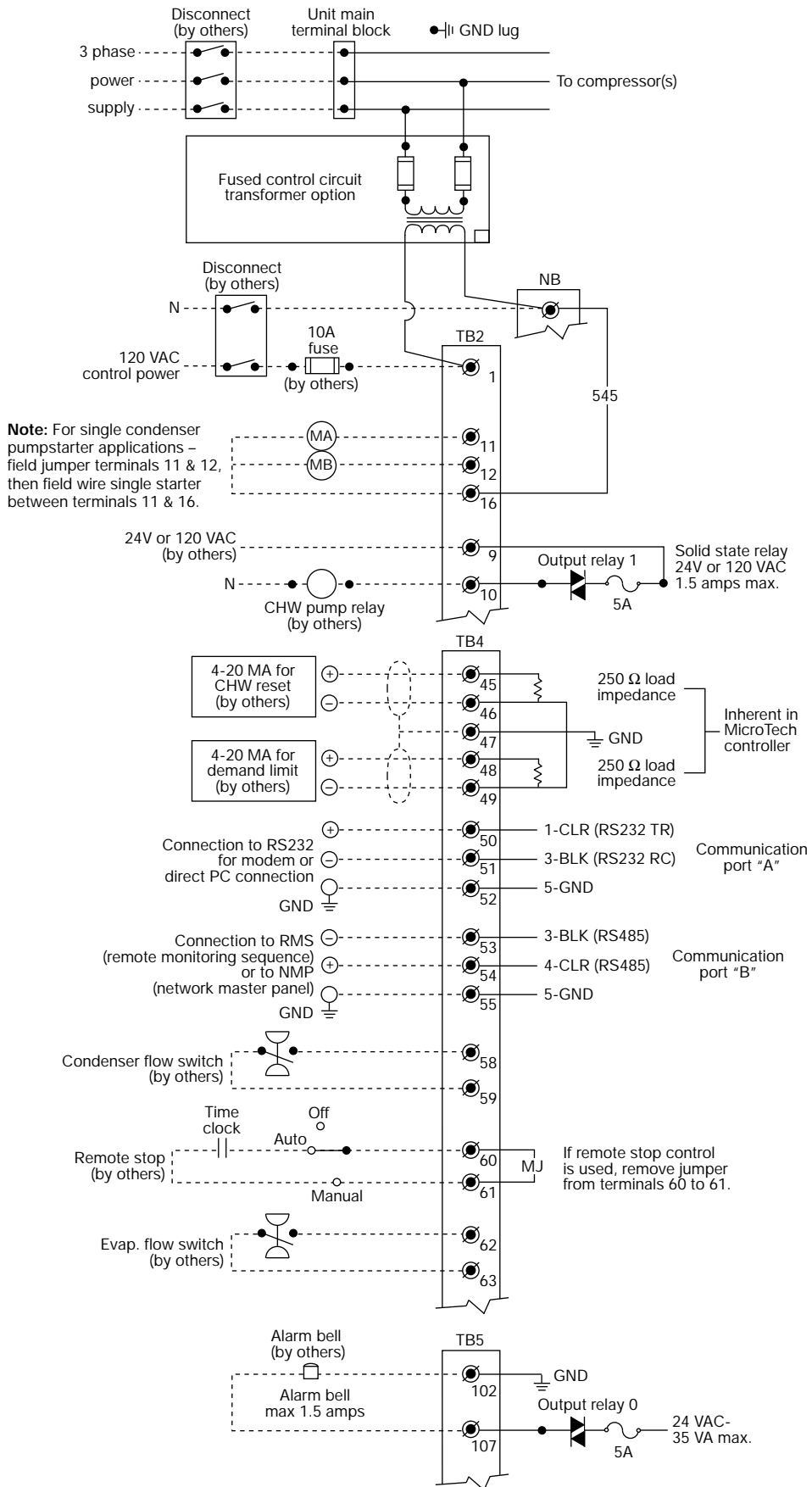



13600 Industrial Park Boulevard, P.O. Box 1551, Minneapolis, MN 55440 USA (612) 553-5330