

Model number nomenclature



30XA A 400 6 T - 0 - N M 3

30XA A 200 6 F - 0 - - - - L

30XA – AquaForce® Air-Cooled Chiller

Design Series

Unit Sizes

080 140 240 350
090 160 260 **400**
100 180 280 450
110 200 300 500
120 220 325

Voltage

1 – 575-3-60
2 – 380-3-60
4 – 230-3-60
6 – 460-3-60
7 – 200-3-60

Condenser Coil/Ambient/Low Sound Options

- – Aluminum Fin/Copper Tube, High Ambient Temperature
0 – Copper Fin/Copper Tube, High Ambient Temperature
1 – Aluminum Pre-Coat Fin/Copper Tube, High Ambient Temperature
2 – Aluminum E-Coat Fin/Copper Tube, High Ambient Temperature
3 – Copper E-Coat Fin/Copper Tube, High Ambient Temperature
4 – Novation® Heat Exchanger (MCHX), High Ambient Temperature
5 – MCHX E-Coat, High Ambient Temperature
6 – Aluminum Fin/Copper Tube, High Ambient Temperature, Low Sound
7 – Copper Fin/Copper Tube, High Ambient Temperature, Low Sound
8 – Aluminum Pre-Coat Fin/Copper Tube, High Ambient Temperature, Low Sound
9 – Aluminum E-Coat Fin/Copper Tube, High Ambient Temperature, Low Sound
B – Copper E-Coat Fin/Copper Tube, High Ambient Temperature, Low Sound
C – MCHX, High Ambient Temperature, Low Sound
D – MCHX E-Coat, High Ambient Temperature, Low Sound
F – Aluminum Fin/Copper Tube, Standard Ambient Temperature, Low Sound
G – Copper Fin/Copper Tube, Standard Ambient Temperature, Low Sound
H – Aluminum Pre-Coat Fin/Copper Tube, Standard Ambient Temperature, Low Sound
J – Aluminum E-Coated Fin/Copper Tube, Standard Ambient Temperature, Low Sound
K – Copper E-Coat Fin/Copper Tube, Standard Ambient Temperature, Low Sound
L – MCHX, Standard Ambient Temperature, Low Sound
M – MCHX E-Coat, Standard Ambient Temperature, Low Sound
N – Aluminum Fin/Copper Tube, Standard Ambient Temperature
P – Copper Fin/Copper Tube, Standard Ambient Temperature
Q – Aluminum Pre-Coat Fin/Copper Tube, Standard Ambient Temperature
R – Aluminum E-Coat Fin/Copper Tube, Standard Ambient Temperature
S – Copper E-Coat Fin/Copper Tube, Standard Ambient Temperature
T – MCHX, Standard Ambient Temperature
V – MCHX E-Coat, Standard Ambient Temperature

Hydronic Pump Package Options

- – None
1 – Single Pump, 5 HP
2 – Single Pump, 7.5 HP
3 – Single Pump, 10 HP
4 – Single Pump, 15 HP
7 – Dual Pump, 5 HP
8 – Dual Pump, 7.5 HP
B – Dual Pump, 10 HP
C – Dual Pump, 15 HP

Cooler/Brine Options

0 – Integral Cooler with Heater
3 – Integral Cooler with Heater, Minus One Pass
5 – Integral Cooler with Heater, Plus One Pass
7 – Integral Cooler with Heater, Full End Screen
H – Integral Cooler with Heater, Plus One Pass, Brine
K – Integral Cooler with Heater, Minus One Pass, Full End Screen
M – Integral Cooler with Heater, Plus One Pass, Full End Screen
V – Integral Cooler with Heater, Plus One Pass, Brine, Full End Screen

Packaging/Security Options

0 – Coil Face Shipping Protection (CFSP), Skid
1 – CFSP, Skid, Top Crate, Bag
3 – CFSP, Coil Trim Panels
4 – CFSP, Skid, Coil Trim Panels
5 – CFSP, Skid, Top Crate, Bag, Coil Trim Panels
7 – CFSP, Coil Trim Panels, Upper and Lower Grilles
8 – CFSP, Skid, Coil Trim Panels, Upper and Lower Grilles
9 – CFSP, Skid, Top Crate, Bag, Coil Trim Panels, Upper and Lower Grilles
C – CFSP, Trim Panels, Upper and Lower Grilles, Upper Hail Guards
D – CFSP, Skid, Coil Trim Panels, Upper and Lower Grilles, Upper Hail Guards
F – CFSP, Skid, Top Crate, Bag, Trim Panels, Upper and Lower Grilles, Upper Hail Guards
L – CFSP

Controls/Communication Options

- – Navigator™ Display
0 – Navigator Display, EMM
1 – Navigator Display, Service Option
2 – Navigator Display, EMM, Service Option
3 – Touch Pilot™ Display
4 – Touch Pilot Display, EMM
5 – Touch Pilot Display, Service Option
6 – Touch Pilot Display, EMM, Service Option
7 – Navigator Display, BACnet Translator
8 – Navigator Display, BACnet Translator, EMM
9 – Navigator Display, BACnet Translator, Service Option
B – Navigator Display, BACnet Translator, EMM, Service Option
C – Touch Pilot Display; BACnet Translator
D – Touch Pilot Display, BACnet Translator, EMM
F – Touch Pilot Display, BACnet Translator, Service Option
G – Touch Pilot Display, BACnet Translator, EMM, Service Option
H – Navigator Display, LON Translator
J – Navigator Display, LON Translator, EMM
K – Navigator Display, LON Translator, Service Option
L – Navigator Display, LON Translator, EMM, Service Option
M – Touch Pilot Display, LON Translator
N – Touch Pilot Display, LON Translator, EMM
P – Touch Pilot Display, LON Translator, Service Option
Q – Touch Pilot Display; LON Translator, EMM, Service Option

Electrical Options

- – Single Point Power, XL, Terminal Block, No Control Transformer
0 – Single Point Power, Wye-Delta, Terminal Block, No Control Transformer
3 – Dual Point Power, XL, Terminal Block, No Control Transformer
4 – Dual Point Power, Wye-Delta, Terminal Block, No Control Transformer
7 – Single Point Power, XL, Disconnect, No Control Transformer
8 – Single Point Power, Wye-Delta, Disconnect, No Control Transformer
C – Dual Point Power, XL, Disconnect, No Control Transformer
D – Dual Point Power, Wye-Delta, Disconnect, No Control Transformer
H – Single Point Power, XL, Terminal Block, Control Transformer
J – Single Point Power, Wye-Delta, Terminal Block, Control Transformer
M – Dual Point Power, XL, Terminal Block, Control Transformer
N – Dual Point Power, Wye-Delta, Terminal Block, Control Transformer
R – Single Point Power, XL, Disconnect, Control Transformer
S – Single Point Power, Wye-Delta, Disconnect, Control Transformer
W – Dual Point Power, XL, Disconnect, Control Transformer
X – Dual Point Power, Wye-Delta, Disconnect, Control Transformer

Refrigeration Circuit Options

- – None
0 – Suction Line Insulation
1 – Suction Service Valves
2 – Low Ambient Temperature Head Pressure Control
3 – Suction Line Insulation, Suction Service Valves
4 – Suction Line Insulation, Low Ambient Temperature Head Pressure Control
5 – Suction Service Valves, Low Ambient Temperature Head Pressure Control
6 – Suction Line Insulation, Suction Service Valves, Low Ambient Temperature Head Pressure Control
7 – Minimum Load Control
8 – Suction Line Insulation, Minimum Load Control
9 – Suction Service Valves, Minimum Load Control
B – Low Ambient Temperature Head Pressure Control, Minimum Load Control
C – Suction Line Insulation, Suction Service Valves, Minimum Load Control
D – Suction Line Insulation, Low Ambient Temperature Head Pressure Control, Minimum Load Control
F – Suction Service Valves, Low Ambient Temperature Head Pressure Control, Minimum Load Control
G – Suction Line Insulation, Suction Service Valves, Low Ambient Temperature Head Pressure Control, Minimum Load Control

LEGEND

CFSP – Coil Face Shipping Protection
EMM – Energy Management Module
LON – Local Operating Network
XL – Across-the-Line Starter

Quality Assurance

Certified to ISO 9001:2000

30XA400 SINGLE POINT

NOTES:

1. Unit must have clearances as follows:
 Top — Do not restrict
 Sides and Ends — 6 ft (1.8 m) from solid surface.
2. Temperature relief devices are located on liquid line and economizer assemblies and have 1/4-in. flare connection.
3. 3/8-in. NPT vents and drains located in each cooler head at each end of cooler.
4. Drawing depicts unit with single point power and standard one-pass cooler. Refer to the Packaged Chiller Builder program for other configurations.
5. Actual cooler consists of two separate coolers piped in series at the factory. Piping may be split for rigging.
6. Dimensions are shown in inches. Dimensions in [] are in millimeters.

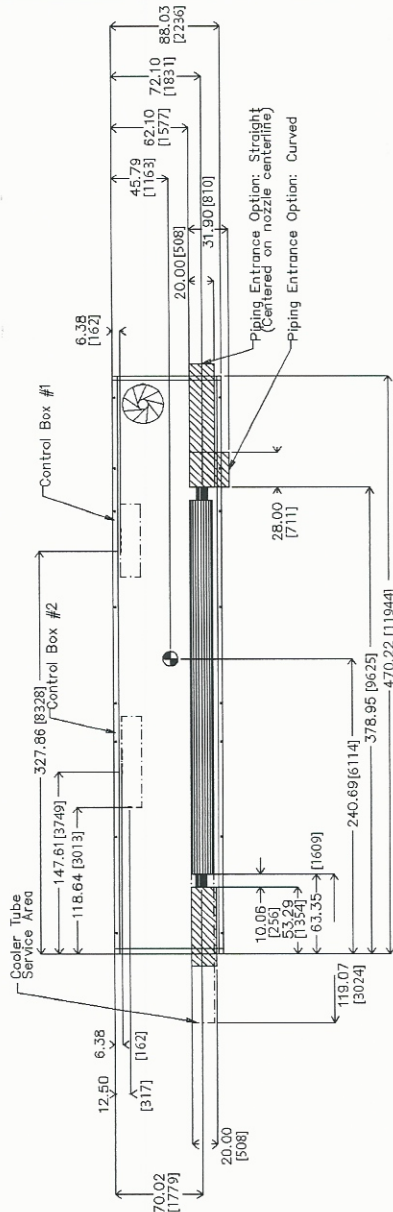

TOP VIEW

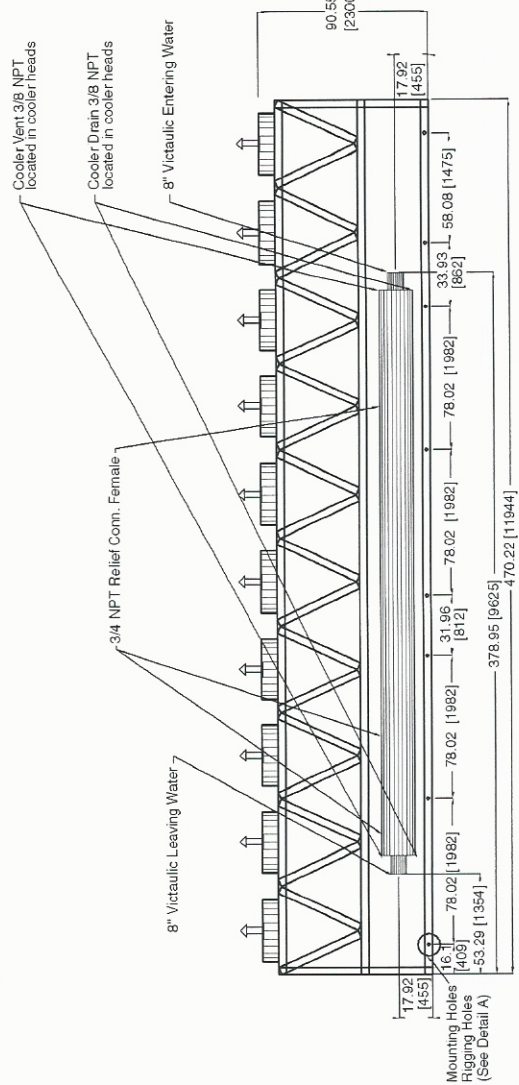

FRONT VIEW

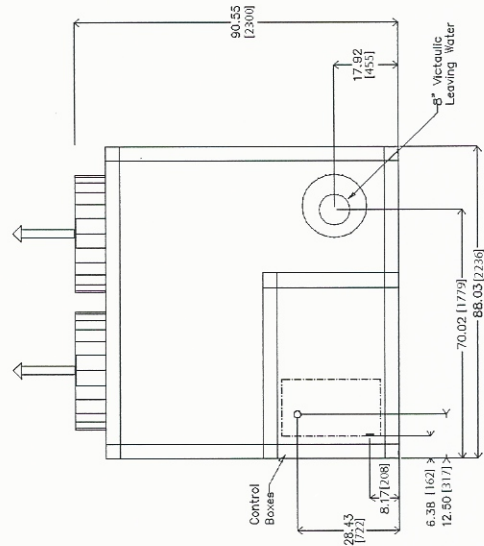

LEFT END VIEW

Dimensions (cont)

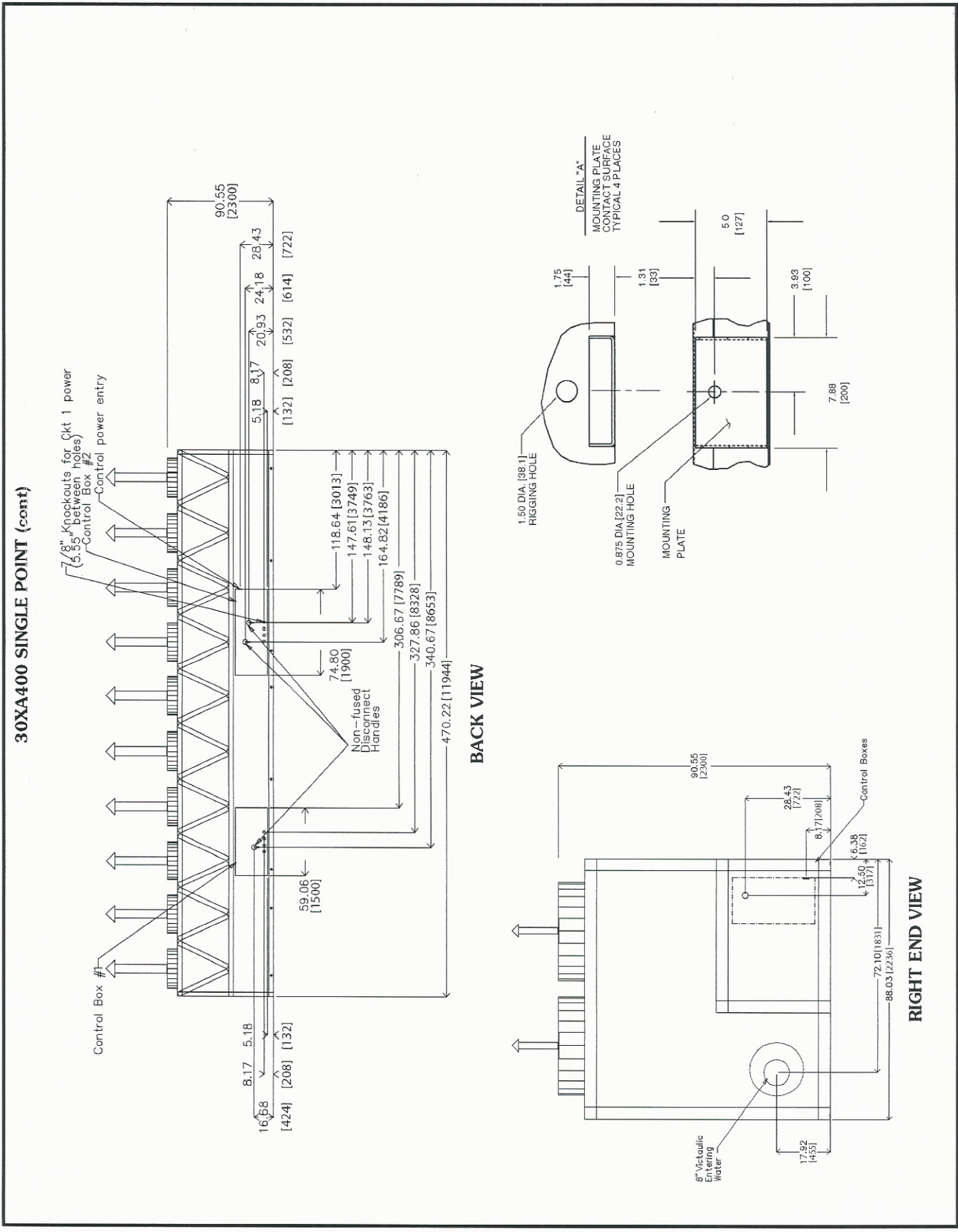

Physical data



30XA080-500 — ENGLISH

UNIT 30XA	080	090	100	110	120	140	160	180	200	220
OPERATING WEIGHT (lb)*										
Al-Cu Condenser Coils	7,674	9,959	10,186	10,326	10,471	12,760	13,003	13,590	13,712	14,727
Cu-Cu Condenser Coils	8,398	10,924	11,151	11,291	11,436	13,966	14,209	15,037	15,159	16,295
MCHX Condenser Coils	7,234	9,382	9,603	9,738	9,877	12,023	12,255	12,899	12,959	13,748
REFRIGERANT TYPE	R-134a, EXV Controlled System									
Refrigerant Charge (lb) Ckt A/Ckt B/Ckt C	110/110/—	110/110/—	120/120/—	135/120/—	135/135/—	202/121/—	225/159/—	205/205/—	225/225/—	270/225/—
Refrigerant Charge (lb) Ckt A/Ckt B/Ckt C (MCHX)	98/98/—	94/94/—	96/96/—	100/96/—	100/100/—	136/96/—	135/100/—	141/111/—	161/161/—	170/161/—
COMPRESSORS	Semi-Hermetic Twin Rotary Screws									
Quantity	2	2	2	2	2	2	2	2	2	2
Speed (rpm)	2	2	2	2	3500	2	2	2	2	2
(Qty) Compressor Model Number Ckt A	(1) 06TS-137†	(1) 06TS-137	(1) 06TS-155	(1) 06TS-186	(1) 06TS-186	(1) 06TT-266	(1) 06TT-301	(1) 06TT-266	(1) 06TT-301	(1) 06TT-356
(Qty) Compressor Model Number Ckt B	(1) 06TS-137†	(1) 06TS-137	(1) 06TS-155	(1) 06TS-186	(1) 06TS-186	(1) 06TS-155	(1) 06TS-186	(1) 06TT-266	(1) 06TT-301	(1) 06TT-301
(Qty) Compressor Model Number Ckt C	N/A	N/A	N/A	N/A	N/A	N/A	N/A	N/A	N/A	N/A
Oil Charge (gal), Ckt A/Ckt B/Ckt C	5.5/5.5/—	5.5/5.5/—	5.5/5.5/—	5.5/5.5/—	5.5/5.5/—	6.25/6.25/—	6.25/6.25/—	6.25/6.25/—	6.25/6.25/—	6.75/6.25/—
Minimum Capacity Step (%)	15	15	15	14	15	11	11	15	15	14
Standard	9	9	9	8	10	7	8	10	10	10
Optional	—	—	—	—	—	—	—	—	—	—
COOLER	Flooded, Shell and Tube Type									
Net Fluid Volume (gal.)	16.5	18.5	18.5	20.0	23.0	25.5	27.5	31.5	34.0	37.0
Maximum Refrigerant Pressure (psig)	220	220	220	220	220	220	220	220	220	220
Maximum Water Side Pressure Without Pumps (psig)	300	300	300	300	300	300	300	300	300	300
Maximum Water Side Pressure With Pumps (psig)	—	150	150	150	150	150	150	—	—	—
WATER CONNECTIONS										
Drain (NPT, in.)	3/8	3/8	3/8	3/8	3/8	3/8	3/8	3/8	3/8	3/8
Standard, Inlet and Outlet, Victaulic (in.)	5	5	5	5	5	5	5	6	6	6
Number of Passes	2	2	2	2	2	2	2	2	2	2
Minus 1 Pass, Inlet and Outlet, Victaulic (in.)	5	5	5	5	5	5	5	8	8	8
Number of Passes	1	1	1	1	1	1	1	1	1	1
Plus 1 Pass, Inlet and Outlet, Victaulic (in.)	4	4	4	4	4	5	5	6	6	6
Number of Passes	3	3	3	3	3	3	3	3	3	3
CONDENSER FANS	Shrouded Axial Type, Vertical Discharge									
Fan Speed (rpm) Standard/High Ambient**	850/—	850/—	850/—	850/—	850/—	850/1140	850/1140	850/1140	850/1140	850/1140
No. Blades...Diameter (in.)	9...30	9...30	9...30	9...30	9...30	9...30	9...30	9...30	9...30	9...30
No. Fans (Ckt A/Ckt B/Ckt C)	3/3/—	4/4/—	4/4/—	4/4/—	4/4/—	6/4/—	6/4/—	6/6/—	6/6/—	7/6/—
Total Airflow (cfm) 850 rpm	55,800	74,400	74,400	74,400	74,400	93,000	93,000	111,500	111,500	120,900
Total Airflow (cfm) 1140 rpm	—	—	—	—	—	124,000	124,000	148,800	148,800	161,200
CONDENSER COILS										
No. Coils (Ckt A/Ckt B/Ckt C)	3/3/—	4/4/—	4/4/—	4/4/—	4/4/—	6/4/—	6/4/—	6/6/—	6/6/—	7/6/—
Total Face Area (sq ft)	141	188	188	188	188	234	234	281	281	305
HYDRONIC MODULE (Optional)	Pump(s) with pressure/temperature taps and combination valve. Single or Dual, 3600 rpm									
Pump	N/A	—	—	—	—	—	—	N/A	—	—
CHASSIS DIMENSIONS (ft-in.)										
Length	11-10	—	15-9	—	—	19-8	—	23-7	—	27-6
Width	—	—	—	—	—	7-4 3/4	—	—	—	—
Height	—	—	—	—	—	7-6 7/16	—	—	—	—

UNIT 30XA	240	260	280	300	325	350	400	450	500	
OPERATING WEIGHT (lb)*										
Al-Cu Condenser Coils	14,887	16,853	17,022	17,362	18,834	19,040	24,578	26,500	26,894	
Cu-Cu Condenser Coils	16,455	18,662	18,931	19,222	21,005	21,211	26,990	29,254	29,547	
MCHX Condenser Coils	13,897	15,720	15,878	16,141	17,467	17,659	23,038	24,301	25,187	
REFRIGERANT TYPE	R-134a, EXV Controlled System									
Refrigerant Charge (lb) Ckt A/Ckt B/Ckt C	270/270/—	375/220/—	375/270/—	415/270/—	415/270/—	415/375/—	270/270/375	415/205/415	415/270/415	
Refrigerant Charge (lb) Ckt A/Ckt B/Ckt C (MCHX)	170/168/—	247/165/—	240/170/—	245/170/—	240/240/—	245/240/—	170/170/215	236/170/227	243/177/227	
COMPRESSORS	Semi-Hermetic Twin Rotary Screws									
Quantity	2	2	2	2	2	2	3	3	3	
Speed (rpm)	2	2	2	2	3500	2	2	2	2	
(Qty) Compressor Model Number Ckt A	(1) 06TT-356	(1) 06TU-483	(1) 06TU-483	(1) 06TU-554	(1) 06TU-483	(1) 06TU-554	(1) 06TT-356	(1) 06TU-554	(1) 06TU-554	
(Qty) Compressor Model Number Ckt B	(1) 06TT-356	(1) 06TT-301	(1) 06TT-356	(1) 06TT-356	(1) 06TU-483	(1) 06TU-483	(1) 06TT-356	(1) 06TT-266	(1) 06TT-356	
(Qty) Compressor Model Number Ckt C	N/A	N/A	N/A	N/A	N/A	N/A	(1) 06TU-483	(1) 06TU-554	(1) 06TU-554	
Oil Charge (gal), Ckt A/Ckt B/Ckt C	6.75/6.75/—	7.5/6.75/—	7.5/6.75/—	7.5/6.75/—	7.5/7.5/—	7.5/7.5/—	6.75/6.75/7.5	7.5/6.25/7.5	7.5/6.75/7.5	
Minimum Capacity Step (%)	15	11	13	12	15	15	9	6	7	
Standard	10	8	9	7	10	10	6	4	5	
Optional	—	—	—	—	—	—	—	—	—	
COOLER	Flooded, Shell and Tube Type									
Net Fluid Volume (gal.)	39.0	42.0	44.0	48.5	50.5	53.4	68.0	75.0	83.0	
Maximum Refrigerant Pressure (psig)	220	220	220	220	220	220	220	220	220	
Maximum Water Side Pressure Without Pumps (psig)	300	300	300	300	300	300	300	300	300	
Maximum Water Side Pressure With Pumps (psig)	—	—	—	—	—	—	—	—	—	
WATER CONNECTIONS										
Drain (NPT, in.)	3/8	3/8	3/8	3/8	3/8	3/8	3/8	3/8	3/8	
Standard, Inlet and Outlet, Victaulic (in.)	6	8	8	8	8	8	8	8	8	
Number of Passes	2	2	2	2	2	2	1	1	1	
Minus 1 Pass, Inlet and Outlet, Victaulic (in.)	8	8	8	8	8	8	—	—	—	
Number of Passes	1	1	1	1	1	1	—	—	—	
Plus 1 Pass, Inlet and Outlet, Victaulic (in.)	6	8	8	8	8	8	—	—	—	
Number of Passes	3	3	3	3	3	3	—	—	—	
CONDENSER FANS	Shrouded Axial Type, Vertical Discharge									
Fan Speed (rpm) Standard/High Ambient**	850/1140	850/1140	850/1140	850/1140	850/1140	850/1140	850/1140	850/1140	850/1140	
No. Blades...Diameter (in.)	9...30	9...30	9...30	9...30	9...30	9...30	9...30	9...30	9...30	
No. Fans (Ckt A/Ckt B/Ckt C)	7/6/—	9/6/—	9/7/—	10/6/—	9/9/—	9/9/—	6/6/8	8/6/8	8/6/8	
Total Airflow (cfm) 850 rpm	120,900	139,500	148,800	148,800	167,400	167,400	186,000	204,600	204,600	
Total Airflow (cfm) 1140 rpm	161,200	186,000	198,400	198,400	223,200	223,200	248,000	272,800	272,800	
CONDENSER COILS										
No. Coils (Ckt A/Ckt B/Ckt C)	7/6/—	9/6/—	9/7/—	10/6/—	9/9/—	9/9/—	6/6/8	8/6/8	8/6/8	
Total Face Area (sq ft)	305	352	375	375	422	422	469	516	516	
HYDRONIC MODULE (Optional)	Pump									
Pump	—	—	—	—	—	N/A	—	—	—	
CHASSIS DIMENSIONS (ft-in.)										
Length	27-6	—	31-5	—	—	35-4	—	39-3	—	
Width	—	—	—	—	—	7-4 3/4	—	—	—	
Height	—	—	—	—	—	7-6 7/16	—	—	—	

LEGEND

- Cu — Copper
- Al — Aluminum
- EXV — Electronic Expansion Valve
- MCHX — Microchannel Heat Exchanger
- N/A — Not Applicable

*Operating weight includes 2 pumps on models 30XA090-160. No pumps are available on 30XA080 or 30XA180-500. All weights include coil trim panels. See pages 8-19 for mounting weights for units without pumps and units with single pump packages.
 †30XA080 unit does not have an economizer.
 **The high ambient temperature option is not available on 30XA090-120 units.