



# ESWA™

172 Ton  
2012

## CLOSED CIRCUIT COOLER

Model #: ESWA-77-35J-Z  
Serial #: 12-470283



Now Available! Optional  
**TITAN COIL**  
Featuring  
**304L SST**  
Elliptical Tube Construction  
and a  
**5 YEAR COIL Warranty!**



FEATURING EVAPCO'S EXCLUSIVE

### Sensi-COIL™

TECHNOLOGY

L: 11' 0"  
W: 8' 6"  
H: 15' 9"

Operating Weight: 13,480 lbs  
Shipping Weight: 9,640 lbs

# ESWA Engineering Data & Dimensions

## ESWA Models 77-35H to 77-46K

**Note:** The coil connections increase to 6" BFW when the flow rate exceeds 450 gpm. This required option is referred to as the High Flow coil configuration.

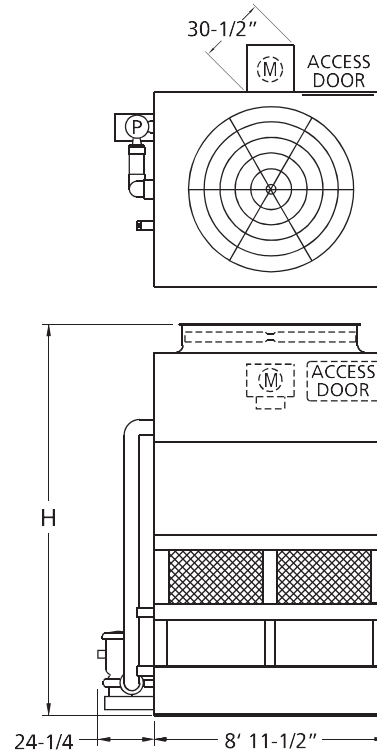
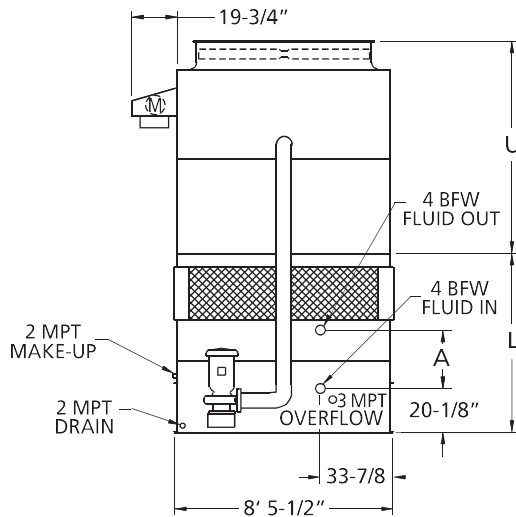

Model Number <sup>1</sup>	Weights (lbs.)			Fans		Spray Pump		Coil Volume (gallons)	Remote Sump <sup>4</sup>			Dimensions <sup>5</sup>			
	Shipping	Heaviest Section <sup>2</sup>	Operating	HP	CFM	HP	GPM		Gallons Required <sup>3</sup>	Conn. Size	Operating Weight (lbs.)	Lower L	Upper U	Coil A	Height H
ESWA 77-35H	9,500	6,370	13,340	7.5	39,500	5	650	174	250	8"	11,930	7' 6-3/8"	8' 2-1/8"	34-1/2"	15' 8-1/2"
ESWA 77-35I	9,510	6,370	13,350	10	43,400	5	650	174	250	8"	11,940	7' 6-3/8"	8' 2-1/8"	34-1/2"	15' 8-1/2"
<b>ESWA 77-35J</b>	9,640	6,370	13,480	15	49,600	5	650	174	250	8"	12,070	7' 6-3/8"	8' 2-1/8"	34-1/2"	15' 8-1/2"
ESWA 77-35K	9,700	6,370	13,540	20	54,800	5	650	174	250	8"	12,130	7' 6-3/8"	8' 2-1/8"	34-1/2"	15' 8-1/2"
ESWA 77-36H	10,280	7,150	14,390	7.5	39,500	5	650	206	250	8"	12,980	8' 1-7/8"	8' 2-1/8"	42"	16' 4"
ESWA 77-36I	10,290	7,150	14,400	10	43,400	5	650	206	250	8"	12,990	8' 1-7/8"	8' 2-1/8"	42"	16' 4"
ESWA 77-36J	10,420	7,150	14,530	15	49,600	5	650	206	250	8"	13,120	8' 1-7/8"	8' 2-1/8"	42"	16' 4"
ESWA 77-36K	10,480	7,150	14,590	20	54,800	5	650	206	250	8"	13,180	8' 1-7/8"	8' 2-1/8"	42"	16' 4"
ESWA 77-43I	8,310	4,850	11,600	10	42,800	5	650	109	250	8"	10,190	6' 3-3/8"	9' 2-1/8"	19-1/2"	15' 5-1/2"
ESWA 77-43J	8,440	4,850	11,730	15	48,900	5	650	109	250	8"	10,320	6' 3-3/8"	9' 2-1/8"	19-1/2"	15' 5-1/2"
ESWA 77-43K	8,500	4,850	11,790	20	53,500	5	650	109	250	8"	10,380	6' 3-3/8"	9' 2-1/8"	19-1/2"	15' 5-1/2"
ESWA 77-44I	9,040	5,580	12,610	10	42,800	5	650	141	250	8"	11,200	6' 10-7/8"	9' 2-1/8"	27"	16' 1"
ESWA 77-44J	9,170	5,580	12,740	15	48,900	5	650	141	250	8"	11,330	6' 10-7/8"	9' 2-1/8"	27"	16' 1"
ESWA 77-44K	9,230	5,580	12,800	20	53,500	5	650	141	250	8"	11,390	6' 10-7/8"	9' 2-1/8"	27"	16' 1"
ESWA 77-45I	9,830	6,370	13,670	10	42,800	5	650	174	250	8"	12,260	7' 6-3/8"	9' 2-1/8"	34-1/2"	16' 8-1/2"
ESWA 77-45J	9,960	6,370	13,800	15	48,900	5	650	174	250	8"	12,390	7' 6-3/8"	9' 2-1/8"	34-1/2"	16' 8-1/2"
ESWA 77-45K	10,020	6,370	13,860	20	53,500	5	650	174	250	8"	12,450	7' 6-3/8"	9' 2-1/8"	34-1/2"	16' 8-1/2"
ESWA 77-46I	10,620	7,160	14,730	10	42,800	5	650	206	250	8"	13,310	8' 1-7/8"	9' 2-1/8"	42"	17' 4"
ESWA 77-46J	10,750	7,160	14,860	15	48,900	5	650	206	250	8"	13,440	8' 1-7/8"	9' 2-1/8"	42"	17' 4"
ESWA 77-46K	10,810	7,160	14,920	20	53,500	5	650	206	250	8"	13,500	8' 1-7/8"	9' 2-1/8"	42"	17' 4"

- Model numbers will end in "-Z" for units with Series Flow piping configuration. Series Flow will require factory internal crossover piping. Model numbers will include "C" for units with stainless steel coil(s), "R" for units with low sound fan(s) and "S" for units with an option that negates CTI Certification.
- Heaviest section is the lower section.
- Gallons shown includes water in suspension in unit and piping. Allow for additional water in bottom of remote sump to cover pump suction and strainer during operation (12" would normally be sufficient).
- When a remote sump arrangement is selected, the spray pump, suction strainer and associated piping are omitted; the unit is provided with an oversized outlet to facilitate drainage to the remote sump.
- Unit dimensions may vary slightly from catalog. See factory certified prints for exact dimensions. Coil connections are 4 inch bevel for weld (BFW). Other connection types such as grooved for mechanical coupling or flanged are also available as options.