



Model #: AGZ090DHHNN-ER10
Serial #: STNU130300033



Model AGZ-D (Rev 0A)
Air-Cooled Scroll-Compressor Chillers
25 to 190 Tons • R-410A • 60Hz/50Hz

Catalog 618

Packaged Chillers and Units with Remote Evaporators

L: 11' 3"
W: 7' 4"
H: 8' 5"

Shipping Weight: 5,365
Operating Weight: 5,420



Features and Benefits

Chiller Nomenclature

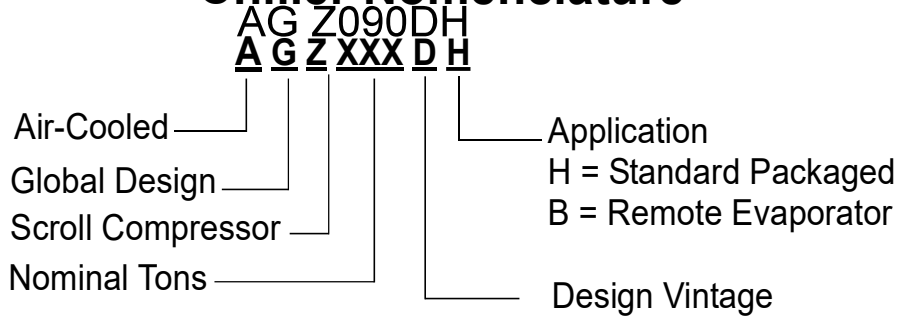

Unit Design Features

Daikin AGZ air-cooled chillers are a product of our commitment to offer quiet, reliable, energy efficient equipment, incorporating high quality compressors, and innovative packaging.

Construction

AGZ chillers are factory-assembled and mounted on a heavy-gauge steel base. The base rails, supports and cabinetry are powder-coat painted for long life. The base distributes the unit weight for roof loading. Their small footprint allows smaller mounting pads or support structures and is a plus for retrofit or replacement applications.

Compressors

Reliable hermetic scroll compressors with cast iron scrolls and three Teflon® impregnated bearings are used on the AGZ-D chillers to promote longevity.

Each model has four to six steps of capacity modulation depending on model size. One to six compressors can run, depending on the load of the system, resulting in excellent part-load efficiency and reduced annual operating costs.

Compressor Communications

The communication module installed in the 20 to 40 ton compressor electrical box provides advanced diagnostics, protection, and communications that enhance compressor performance and reliability.

Features include motor temperature protection, scroll temperature protection, missing phase protection, reverse phase protection, low control circuit voltage protection, short cycling detection and alert, modbus communication to system controller, operational and fault history storage, and LED status display.

Evaporator

Models AGZ-025 through AGZ-130

The evaporator is a compact, high efficiency, dual circuit, brazed plate-to-plate type heat exchanger consisting of parallel stainless steel plates. These heat exchangers provide excellent heat exchange efficiency in a compact footprint and are especially attractive for smaller capacity units.

The water side working pressure is 653 psig (4502 kPa). Evaporators are designed and constructed according to, and listed by, Underwriters Laboratories (UL).

Models AGZ-140 through AGZ-190

The evaporator is direct-expansion, U-tube type with water flowing in the baffled shell side and refrigerant flowing through the tubes. Two independent refrigerant circuits within the evaporator serve the unit's dual refrigerant circuits. The water side working pressure is 152 psig (1048 kPa). Each evaporator is designed, constructed, inspected, and stamped according to the requirements of the ASME Boiler and Pressure Vessel Code. Double thickness insulation is available as an option.

Remote Evaporator (Option)

Units with the optional remote evaporator will have the evaporator shipped separately for field mounting and piping to the outdoor unit.

Condenser Coils

Condenser coils have internally enhanced seamless copper tubes arranged in a staggered row pattern. The coils are mechanically expanded into Daikin lanced and rippled aluminum fins with full fin collars. A variety of optional coil material and coatings are available so that the unit can be constructed to meet almost any environment. Options include copper fins, black fin and ElectroFin® coating; see [page 97](#) for description of options.

Figure 1: The fan deck is canted inward and directs discharge air toward the center of the unit, reducing the tendency to spill over the sides and into the coil, reducing capacity. This feature, combined with the coil design allows closer unit spacing than most competitors. The result is a smaller installation footprint and reduced first cost. The external condenser coils are fitted with a standard wire mesh guards to protect the coil from damage. Optional louvers create an attractive appearance that can eliminate the need for screening walls.

AGZ130D with Optional Full Louver Package



Dimensions - Packaged

Figure 31: AGZ075DH - 100DH (Packaged)

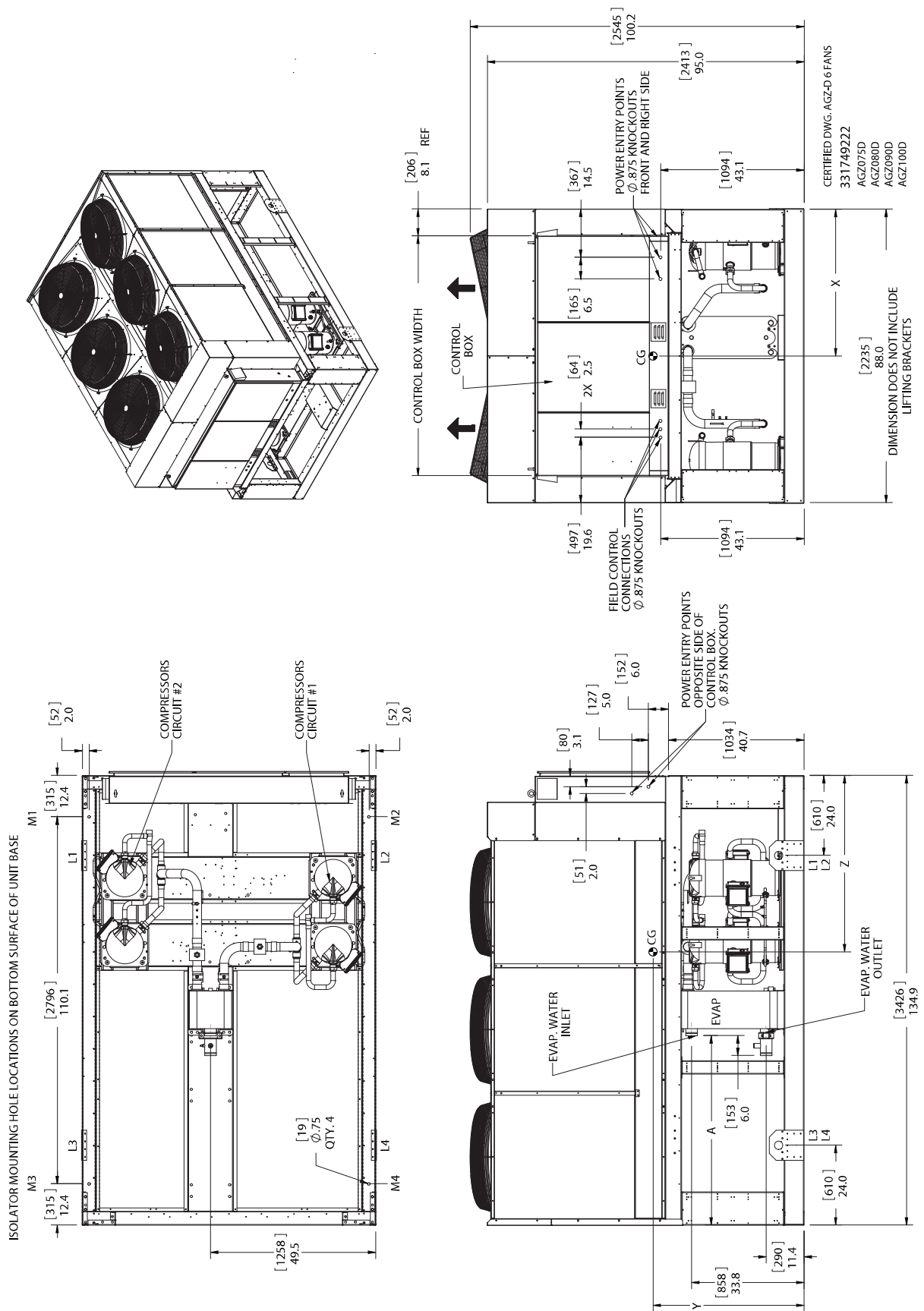

Physical Data - Packaged Units

Table 39: Physical Data - AGZ075D - AGZ100D

PHYSICAL DATA	AGZ-DH (Packaged Chiller) Model Number							
	75		80		90		100	
BASIC DATA	Ckt.1	Ckt.2	Ckt.1	Ckt.2	Ckt.1	Ckt.2	Ckt.1	Ckt.2
Unit Capacity @ AHRI Conditions (See Note 1), Tons (kW)	73 (257)		81 (285)		89 (314)		100 (351)	
Number Of Refrigerant Circuits	2		2		2		2	
Unit Operating Charge, R-410A, lbs (kg)	75 (34)	75 (34)	80 (36)	80 (36)	86 (39)	86 (39)	88 (40)	88 (40)
Cabinet Dimensions, L x W x H, in. (mm)	134.9 x 88.0 x 100.4 (3426 x 2235 x 2550)		134.9 x 88.0 x 100.4 (3426 x 2235 x 2550)		134.9 x 88.0 x 100.4 (3426 x 2235 x 2550)		134.9 x 88.0 x 100.4 (3426 x 2235 x 2550)	
Unit Operating Weight, lbs (kg)	5350 (2427)		5385 (2443)		5420 (2459)		5675 (2574)	
Unit Shipping Weight, lbs (kg)	5305 (2406)		5335 (2420)		5365 (2434)		5610 (2545)	
Add'l Weight for Copper Finned Coils, lbs (kg)	801 (363)		801 (363)		950 (431)		950 (431)	
Add'l Weight for Optional Louvers - Upper, lbs (kg)	237 (108)		237 (108)		237 (108)		237 (108)	
Add'l Weight for Optional Louvers - Lower, lbs (kg)	187 (85)		187 (85)		187 (85)		187 (85)	
COMPRESSORS								
Type	Tandem Scrolls		Tandem Scrolls		Tandem Scrolls		Tandem Scrolls	
Nominal tonnage of each Compressor	20	20	20	25	25	25	25/30	25/30
Number Of Compressors per Circuit	2	2	2	2	2	2	2	2
Oil Charge Per Compressor, oz (g)	135 (3827)	135 (3827)	135 (3827)	145 (4111)	145 (4111)	145 (4111)	145/213 (4111/6038)	145/213 (4111/6038)
CAPACITY REDUCTION STEPS - PERCENT OF COMPRESSOR DISPLACEMENT								
Staging, 4 Stages, Circuit #1 in Lead	0-25-50-75-100		0-22-50-72-100		0-25-50-75-100		0-22-50-72-100	
Staging, 4 Stages, Circuit #2 in Lead	0-25-50-75-100		0-28-50-78-100		0-25-50-75-100		0-22-50-72-100	
CONDENSERS - HIGH EFFICIENCY FIN AND TUBE TYPE WITH INTEGRAL SUBCOOLING								
Coil Face Area, ft ²	66.2	66.2	66.2	66.2	78.8	78.8	78.8	78.8
Coil Face Area, (m ²)	6.1	6.1	6.1	6.1	7.3	7.3	7.3	7.3
Finned Height x Finned Length, in. (mm)	42 x113.4 (1069x2880)	42 x113.4 (1069x2880)	42 x113.4 (1069x2880)	42 x113.4 (1069x2880)	50 x113.4 (1270x2880)	50 x113.4 (1270x2880)	50 x113.4 (1270x2880)	50 x113.4 (1270x2880)
Fins Per Inch x Row s Deep	16 x 3	16 x 3	16 x 3	16 x 3	16 x 3	16 x 3	16 x 3	16 x 3
Pumpdown Capacity, 90% Full lbs (kg)	111 (50)	111 (50)	111 (50)	111 (50)	130 (59)	130 (59)	130 (59)	130 (59)
CONDENSER FANS - DIRECT DRIVE PROPELLER TYPE								
Number Of Fans - Fan Diameter, in. (mm)	6 – 30 (762)		6 – 30 (762)		6 – 30 (762)		6 – 30 (762)	
Number Of Motors - HP (kW)	6 – 2.0 (1.5)		6 – 2.0 (1.5)		6 – 2.0 (1.5)		6 – 2.0 (1.5)	
Fan And Motor RPM, 60Hz	1140		1140		1140		1140	
60 Hz Fan Tip Speed, FPM (m/sec)	8950 (45)		8950 (45)		8950 (45)		8950 (45)	
60 Hz Total Unit Airflow, CFM (l/sec)	61,200 (28,888)		61,200 (28,888)		65,178 (30,765)		65,178 (30,765)	
EVAPORATOR – BRAZED PLATE-TO-PLATE								
Number of Evaporators	1		1		1		1	
Number of Refrigerant Circuits	2		2		2		2	
Water Volume, Gallons, (l)	5.47 (20.7)		6.18 (23.4)		6.66 (25.2)		7.85 (29.7)	
Max. Water Pressure, psig (kPa)	653 (4502)		653 (4502)		653 (4502)		653 (4502)	
Max. Refrigerant Working Pressure, psig (kPa)	653 (4502)		653 (4502)		653 (4502)		653 (4502)	
Water Inlet/Outlet Victaulic Conn. in. (mm)	3 (80)		3 (80)		3 (80)		3 (80)	
Drain - NPT int, in. (mm) (Note 3)	Field Piping		Field Piping		Field Piping		Field Piping	
Vent - NPT int, in. (mm) (Note 3)	Field Piping		Field Piping		Field Piping		Field Piping	

Note 1: Nominal capacity based on 95° F ambient air and 54° F/44° F water range.

Note 2: For all 380V/60 & 575V/60 models, HP = 2.0.

Note 3: Water connection shown is nominal pipe size.

Note 4: Brazed plate evaporators do not have drain or vent connections integral to the heat exchanger. The connections must be installed in the field inlet and outlet piping as shown in Piping Section beginning on of IM 1100, available on www.DaikinApplied.com.