

Model #: WME0500S
Serial #: STNU090700168

DAIKIN McQUAY®



Catalog 604-3

Magnitude™ Magnetic Bearing Centrifugal Chiller

Model WME

400 to 700 tons (1400 to 2461 kW)

3/60/460

HFC-134a

L: 14' 3"
W: 6' 5"
H: 8' 1"

Shipping Weight: 18,216

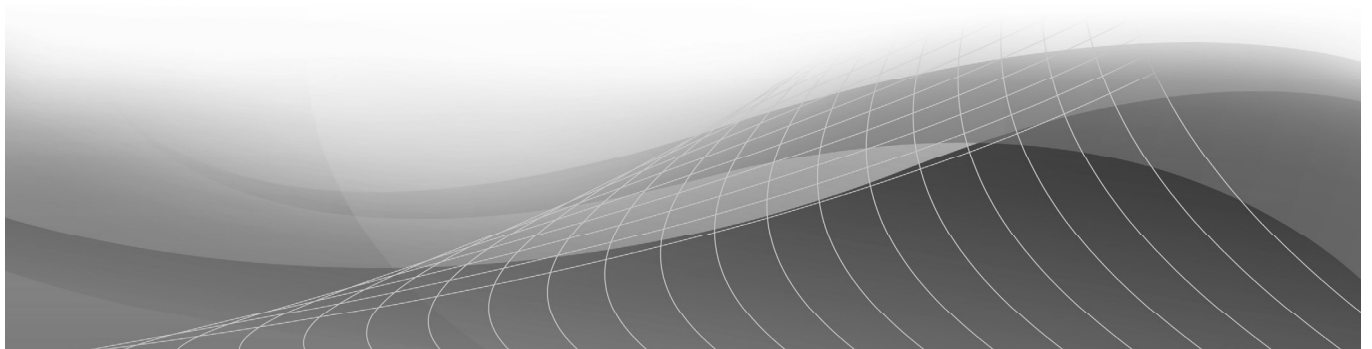
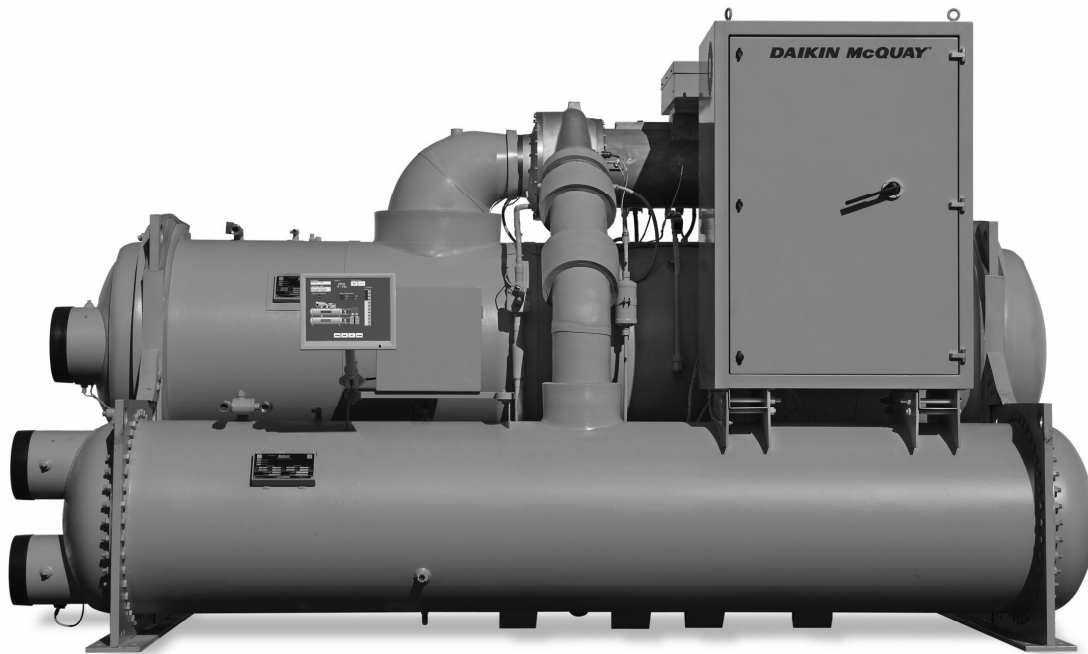

Chiller Identification

Figure 3: Magnitude Code String Chiller Identification

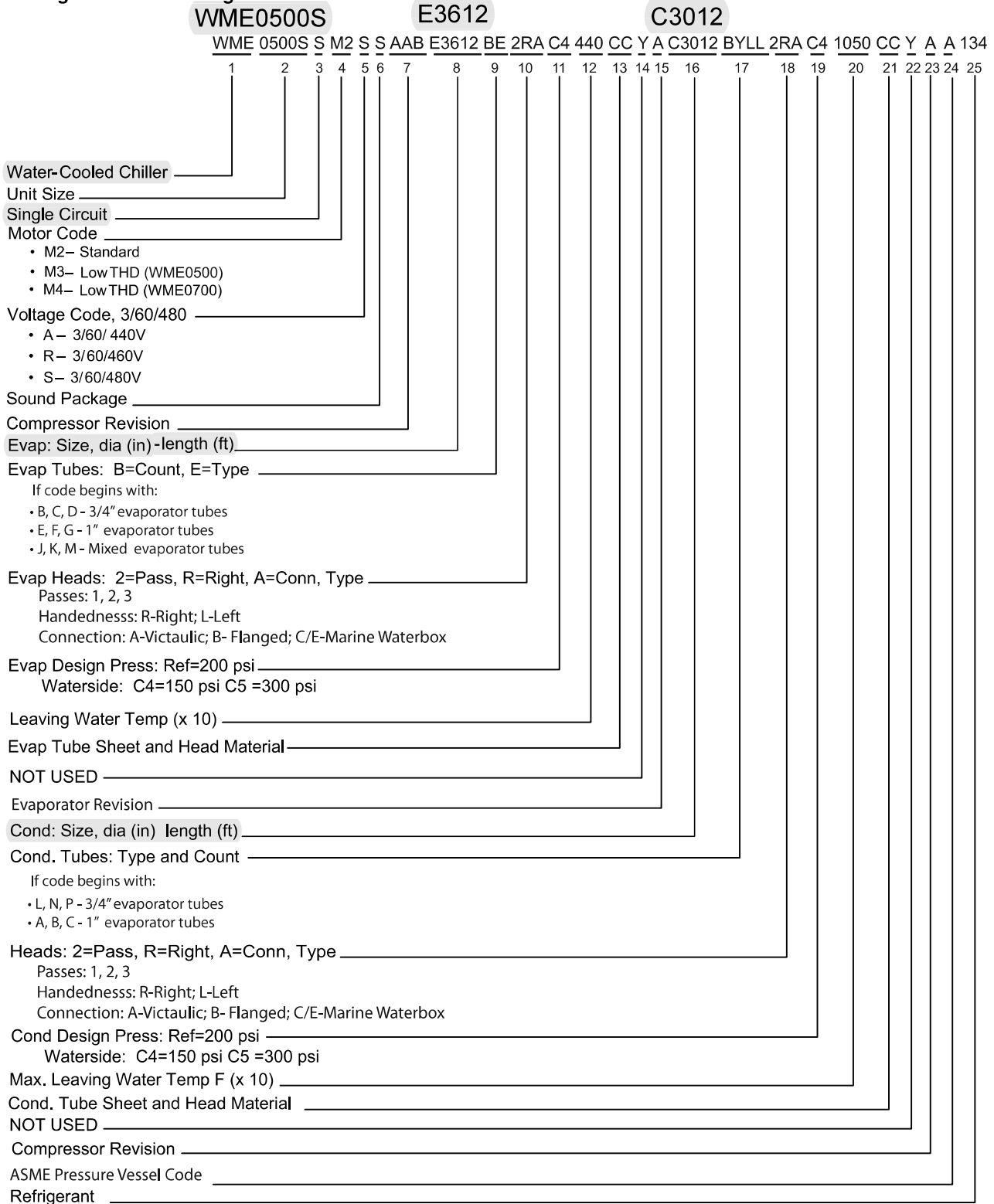

Dimension Drawings

**Figure 8: WME0500 - E3612/C3012 - 2-pass - M2 Motor (50Hz 380/400/415V - 60Hz 380/575V)
 WWME0500 - E3012/C2612 - 2-pass - M2 motor (50Hz 380/400/460V) with Factory-mounted Harmonic Filter
 WME0500 - E3612/C3012 - 2-pass - M3 Low THD Motor (50Hz 380/400/415V - 60Hz 380/440/460/480/575V)**
 (See page 12 for drawing notes.)

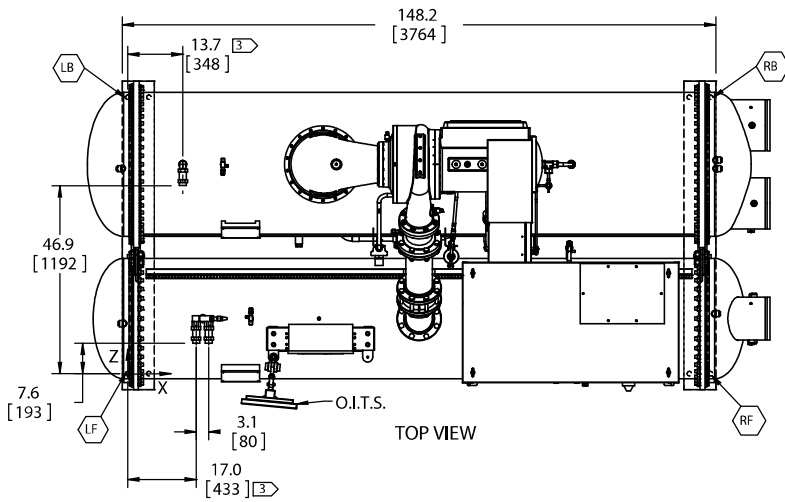

WME0500 M2: 380V (50Hz), 400V (50Hz),
 415V (50Hz), 380V (60Hz),
 575V (60Hz).

WME0500 M3: 380V (50Hz), 400V (50Hz),
 415V (50Hz), 380V (60Hz),
 440V (60Hz), 460V (60Hz),
 480V (60Hz), 575V (60Hz).

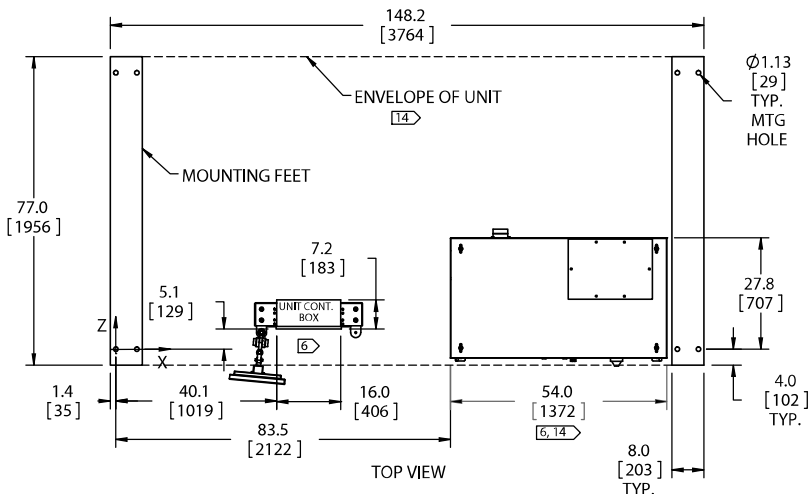
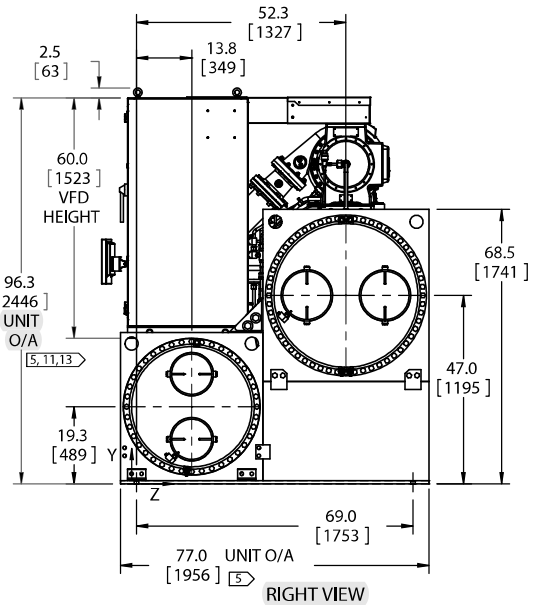
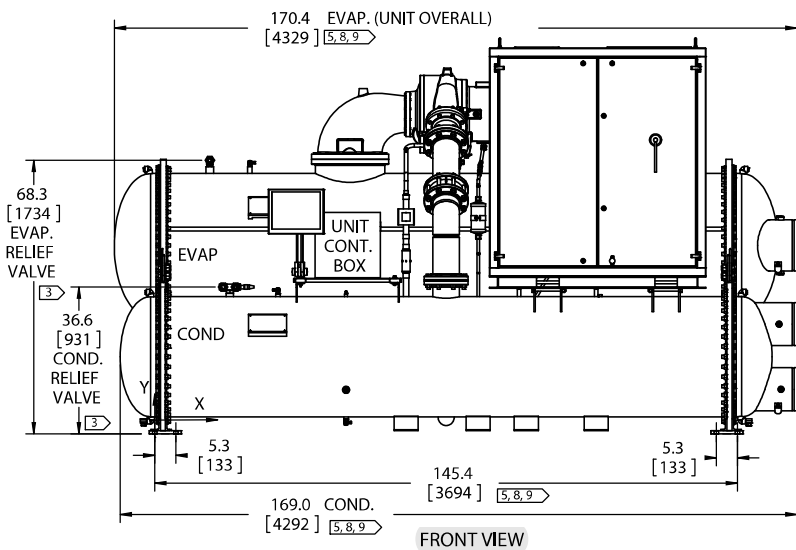

This information is accurate at time of printing. McQuay reserves the right to change design, specification and product data without notice. Purchaser must determine that the equipment is fit and sufficient for the job specifications. No change to this data may be made unless approved in writing by McQuay. McQuay's Limited Product Warranty applies to all McQuay equipment.

ALL DIMENSIONS ARE IN DECIMAL INCHES AND [MILLIMETERS]

333904601 00
 DRAWING NUMBER REV.

Lifting and Mounting Weights

Figure 21: Corner Identification

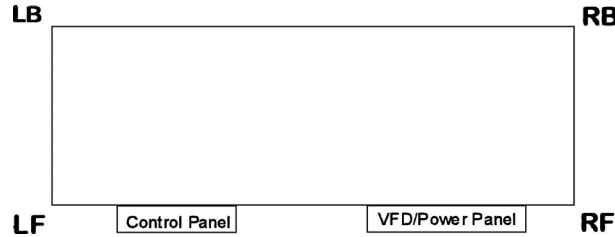

NOTES:

- 1 The block shown above is the mounting footprint, not the entire unit footprint.
- 2 Lifting holes in the top of the tube sheets are 3.25-inch (83 mm) diameter.
- 3 Mounting holes in the feet are 1.125-inch diameter.
- 4 Weights are based on standard configuration; actual weight may vary depending on options. Consult Certified Drawing

Table 10: Lifting and Mounting Weights and Centes of Gravity

WM E Model	Vessel Models	Motor Code	Lifting (Shipping) Weight, lbs (kg)					Center of Gravity in. (mm)		
			LB	LF	RB	RF	Total	X	Y	Z
500	E3012/C2612	M2	2682 (1217)	3380 (1533)	3263 (1480)	4113 (1866)	13438 (6095)	79.8 (2028)	35.1 (891)	25.7 (652)
500	E3012/C2612	M3	2652 (1203)	3667 (1663)	3472 (1575)	4801 (2178)	14592 (6619)	82.5 (2094)	36.6 (929)	24.3 (618)
500	E3012/C3012	M2	2953 (1339)	3769 (1710)	3546 (1609)	4527 (2053)	14795 (6711)	79.4 (2016)	34.7 (881)	27.7 (703)
500	E3012/C3012	M3	2948 (1337)	4031 (1829)	3789 (1719)	5182 (2350)	15950 (7235)	81.8 (2078)	36.4 (924)	26.6 (676)
500	E3612/C3012	M2	3537 (1604)	4314 (1957)	4149 (1882)	5060 (2295)	17060 (7738)	80.7 (2050)	38.1 (969)	29.9 (760)
500	E3612/C3012	M3	3519 (1596)	4591 (2082)	4385 (1989)	5721 (2595)	18216 (8263)	80.7 (2050)	38.1 (969)	29.9 (760)
700	E3612/C3012	M4	3635 (1649)	4598 (2086)	4543 (2061)	5746 (2606)	18522 (8401)	80.8 (2052)	39.4 (1000)	30.5 (774)
700	E3612/C3612	M4	4102 (1861)	5370 (2436)	4995 (2266)	6539 (2966)	21006 (9528)	79.9 (2028)	40.2 (1022)	32.5 (825)
WM E Model	Vessel Models	Motor Code	Mounting (Operating) Weight, lbs (kg)					Center of Gravity in. (mm)		
			LB	LF	RB	RF	Total	X	Y	Z
500	E3012/C2612	M2	3263 (1480)	3896 (1767)	3902 (1770)	4660 (2114)	15721 (7131)	79.2 (2012)	34.8 (883)	26.4 (671)
500	E3012/C2612	M3	3228 (1464)	4189 (1900)	4117 (1867)	5343 (2424)	16877 (7655)	81.5 (2071)	36.1 (916)	25.2 (641)
500	E3012/C3012	M2	3612 (1638)	4446 (2017)	4272 (1938)	5257 (2385)	17587 (7977)	78.8 (2001)	34.2 (868)	28.2 (717)
500	E3012/C3012	M3	3604 (1635)	4712 (2137)	4518 (2049)	5908 (2680)	18742 (8501)	80.9 (2055)	35.6 (905)	27.3 (693)
500	E3612/C3012	M2	4437 (2013)	5077 (2303)	5132 (2328)	5872 (2663)	20518 (9307)	78.0 (1981)	36.7 (933)	32.2 (817)
500	E3612/C3012	M3	4412 (2001)	5359 (2431)	5374 (2438)	6527 (2961)	21672 (9830)	79.9 (2028)	37.9 (962)	31.2 (791)
700	E3612/C3012	M4	4529 (2054)	5366 (2434)	5532 (2509)	6553 (2972)	21980 (9970)	80.0 (2031)	38.9 (989)	31.6 (802)
700	E3612/C3612	M4	5150 (2336)	6461 (2931)	6130 (2781)	7691 (3489)	25432 (11536)	79.0 (2007)	39.7 (1008)	33.3 (845)