

Model#: RTAA1254XH01A3D0BF
Serial#: U96M08881

1996
125 Ton



RLC-DS-2
June 1999

Series R[®]
Rotary Liquid Chiller

70 to 400 Tons
Air-Cooled

L: 19' 2"
W: 7' 5"
H: 7' 4"

Shipping Weight: 8,360
Operating Weight: 8,743

RLC-DS-2

Built For the Industrial and Commercial Markets

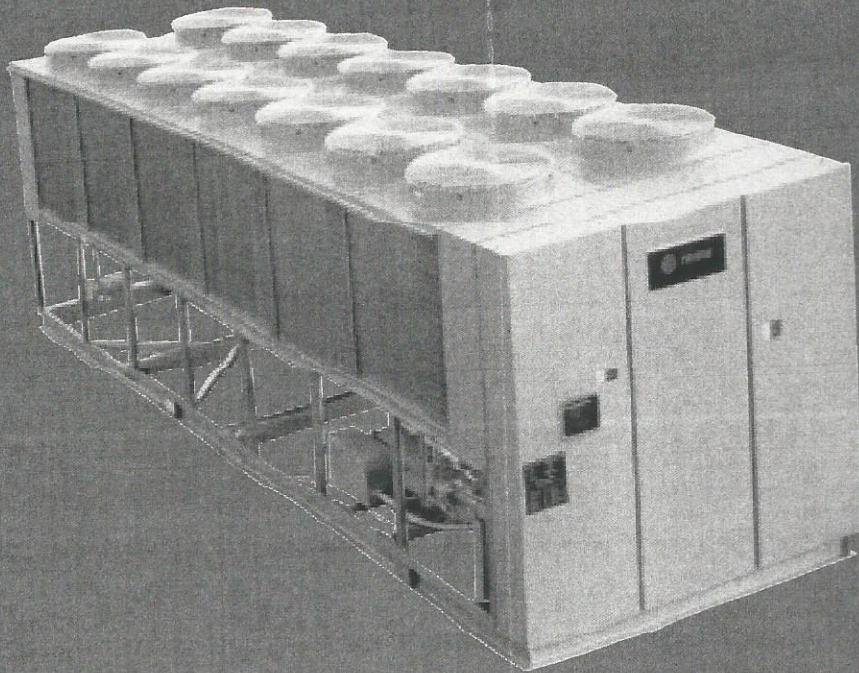



Model Number Description

Model Nomenclature Digit Number

1 2 3 4 5 6 7 8 9 10 11 12 13 14 15 16 17
R T A A 1 2 5 4 X H 0 1 A 3 D 0 B F

70-125 Tons

Digits 1,2 — Unit Model
 RT = Rotary Chiller

Digit 3 — Unit Type
 A = Air Cooled

Digit 4 — Development Sequence
 A = First Sequence

Digit 5, 6 & 7 — Nominal Capacity
 070 = 70 tons
 080 = 80 tons
 090 = 90 tons
 100 = 100 tons
 110 = 110 tons
 125 = 125 tons

Digit 8 — Unit Voltage
 A = 200/60/3
 C = 230/60/3
 D = 380/60/3
 4 = 460/60/3
 5 = 575/60/3
 S = Special

130-400 Tons

Digits 1,2 — Unit Model
 RT = Rotary Chiller

Digit 3 — Unit Type
 A = Air Cooled

Digit 4 — Development Sequence
 A = First Sequence

Digit 5, 6 & 7 — Nominal Capacity
 130 = 130 tons 240 = 240 tons
 140 = 140 tons 270 = 270 tons
 155 = 155 tons 300 = 300 tons
 170 = 170 tons 340 = 340 tons
 185 = 185 tons 370 = 370 tons
 200 = 200 tons 400 = 400 tons
 215 = 215 tons

Digit 8 — Unit Voltage
 G = 200-230/60/3 Dual Voltage
 K = 380-415/50/3 Dual Voltage
 4 = 460/60/3
 5 = 575/60/3
 S = Special
 D = 380/60/3

Digit 9 — Compressor Starter Type
 Y = Y-Delta Closed Transition
 X = X-Line (Across the Line)
 S = Special

Digit 10, 11 — Design Sequence
 ** = Factory Input

Digit 12 — Evaporator Leaving Temperature
 1 = Standard 40 to 65 F
 2 = Low 0 to 39 F
 3 = Ice-Making 20 to 65 F
 S = Special

Digit 13 — Condenser Coil Fin Material
 A = Aluminum
 S = Special

Digit 14 — Agency Listing
 0 = No Agency Listing
 1 = C/UL Listing

Digit 15 — Control Interface
 C = Deluxe without Communication
 D = Deluxe with Communication

Digit 16 — Chilled Water Reset
 0 = No Chilled Water Reset
 1 = Based on Return Water Temperature
 2 = Based on Outside Air Temperature

Digit 17 — Miscellaneous Factory Installed Options
 A = Architectural Louvered Panels
 B = Control Power Transformer
 D = Low Ambient Lockout Sensor
 F = Mech. Disconnect Switch
 G = Low Ambient Operation
 K = Coil Protection
 M = Access Guard
 P = Circuit Breaker (Single Point Power)
 Z = Circuit Breaker (Dual Point Power)

Field Installed Options
 Q = Spring Isolators
 N = Neoprene Isolators
 R = Remote Display Panel
 3 = 5 Year Compressor Warranty
 8 = Architectural Louvered Panels
 9 = Coil Protection
 0 = Access Guard
 J = Remote Evaporator
 H = Sound Attenuator

Digit 9 — Compressor Starter Type
 Y = Y-Delta Closed Transition
 X = X-Line (Across the Line)
 S = Special

Digit 10, 11 — Design Sequence
 ** = Factory Input

Digit 12 — Evaporator Leaving Temperature
 1 = Standard 40 to 65 F
 2 = Low 0 to 39 F
 3 = Ice-Making 20 to 65 F
 S = Special

Digit 13 — Condenser Coil Fin Material
 A = Aluminum
 S = Special

Digit 14 — Agency Listing
 0 = No Agency Listing
 1 = C/UL Listing

Digit 15 — Control Interface
 C = Deluxe without Communication
 D = Deluxe with Communication

Digit 16 — Chilled Water Reset
 0 = No Chilled Water Reset
 1 = Based on Return Water Temperature
 2 = Based on Outside Air Temperature

Digit 17 — Miscellaneous Factory Installed Options
 A = Architectural Louvered Panels
 B = Control Power Transformer
 C = Domestic Water Heater
 D = Low Ambient Lockout Sensor
 F = Mech. Disconnect Switch
 G = Low Ambient Operation
 K = Coil Protection
 M = Access Guard
 P = Circuit Breaker (Single Point Power)
 Z = Circuit Breaker (Dual Point Power)

Field Installed Options
 2 = Remote Display Panel
 5 = 5 Year Compressor Warranty
 N = Neoprene Isolators
 6 = Spring Isolators
 7 = Architectural Louvered Panels
 J = Remote Evaporator
 8 = Coil Protection
 9 = Access Guard
 H = Sound Attenuator

Figure D-1 — R AA 70-125 Unit Dimensions

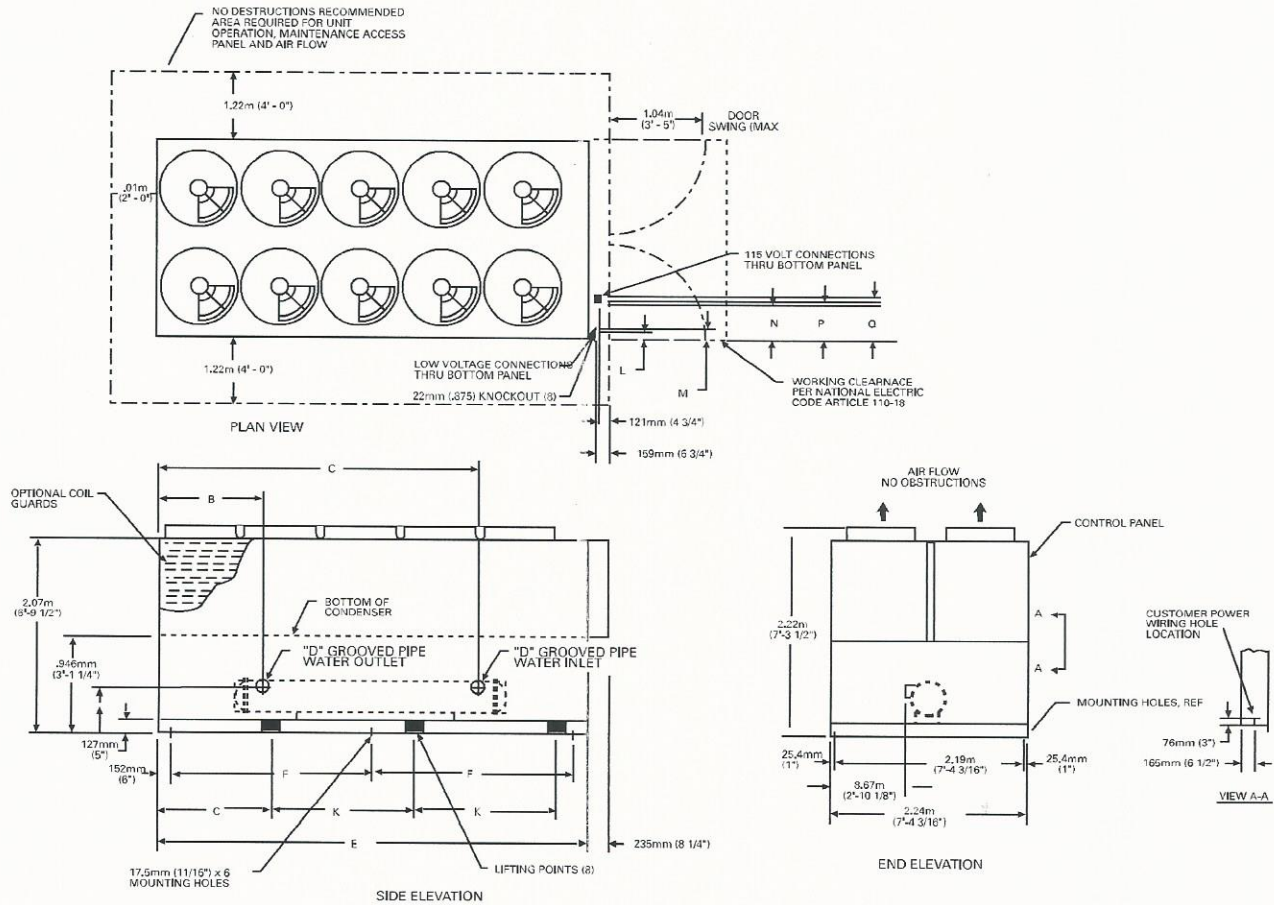

UNIT SIZE	A	B	C	D	E	F	G	K
70-100	.492m (1'-7 3/8")	1.213m (3'-11 3/4")	2.851m (9'-4 1/4")	102mm (4")	4.940m (16'-2 1/2")	2.317m (7'-7 1/4")	1.549m (5'-1")	1.626m (5'-4")
110-125	.479m (1'-6 7/8")	1.032m (3'-4 5/8")	3.499m (11'-5 3/4")	152mm (6")	5.626m (18'-5 1/2")	2.661m (8'-8 3/4")	1.511m (4'-11 1/2")	1.930m (6'-4")

UNIT SIZE	NO. OF FANS PER UNIT					
	70	80	90	100	110	125
NO. FANS						
STD UNIT	8	8	9	10	10	10

PANEL TYPE	115 VOLT & LOW VOLTAGE CONNECTIONS				
	L	M	N	P	Q
X-LINE					
CONTROL	.889m (2'-11")	.927m (3'-0 1/2")	1.206m (3'-11 1/2")	1.245m (4'-1")	1.283m (4'-2 1/2")
PANEL					
WYE DELTA					
CONTROL	76mm (3")	114mm (4 1/2")	.39m (1'-3 1/2")	.43m (1'-5")	.47m (1'-8 1/2")
PANEL					



Weights

Table W-5 — Weights

Unit Size	Units	Isolator Location										Operating Weight	Shipping Weight
		1	2	3	4	5	6	7	8	9	10		
RTAA 70	lbs.	1582	1608	1212	1232	842	856	—	—	—	—	7332	7000
	kg	718	729	550	559	382	388	—	—	—	—	3326	3175
RTAA 80	lbs.	1587	1613	1218	1237	848	862	—	—	—	—	7365	7049
	kg	720	732	552	561	385	391	—	—	—	—	3341	3197
RTAA 90	lbs.	1639	1596	1271	1237	903	879	—	—	—	—	7525	7234
	kg	743	724	577	561	410	399	—	—	—	—	3413	3281
RTAA 100	lbs.	1640	1668	1281	1303	922	937	—	—	—	—	7751	7483
	kg	744	757	581	591	418	425	—	—	—	—	3516	3394
RTAA 110	lbs.	1933	1885	1480	1443	1027	1001	—	—	—	—	8769	8326
	kg	877	855	671	655	466	454	—	—	—	—	3978	3777
RTAA 125	lbs.	1871	1902	1445	1469	1019	1036	—	—	—	—	8742	8360
	kg	849	863	655	666	462	470	—	—	—	—	3965	3792
RTAA 130	lbs.	1982	1729	1657	1446	1332	1163	1007	879	—	—	11195	10792
	kg	899	784	752	656	604	528	457	399	—	—	5078	4895
RTAA 140	lbs.	1989	1737	1664	1453	1339	1169	1013	885	—	—	11249	10867
	kg	902	788	755	659	607	530	459	401	—	—	5103	4929
RTAA 155	lbs.	2109	1748	1797	1489	1484	1230	1172	971	—	—	12000	11392
	kg	957	793	815	675	673	558	532	440	—	—	5443	5167
RTAA 170	lbs.	2143	1735	1843	1492	1543	1249	1242	1006	—	—	12253	11675
	kg	972	787	836	677	700	567	563	456	—	—	5558	5296
RTAA 185	lbs.	2144	1824	1852	1575	1560	1327	1268	1078	—	—	12628	12085
	kg	973	827	840	714	708	602	575	489	—	—	5728	5482
RTAA 200	lbs.	2117	1844	1842	1606	1568	1368	1293	1130	—	—	12768	12261
	kg	960	836	836	728	711	621	587	513	—	—	5792	5562
RTAA 215	lbs.	2162	1997	1957	1808	1752	1618	1546	1428	—	—	14268	13472
	kg	981	906	888	820	795	734	701	648	—	—	6472	6111
RTAA 240	lbs.	2038	2011	1995	1969	1953	1928	1911	1886	1869	1845	19405	18147
	kg	924	912	905	893	886	875	867	855	848	837	8902	8231
RTAA 270	lbs.	2163	2042	2113	1995	2063	1947	2013	1900	1963	1853	20052	18858
	kg	981	926	958	905	936	883	913	862	890	841	9096	8554
RTAA 300	lbs.	2148	2121	2099	2072	2049	2023	2000	1975	1951	1926	20364	19240
	kg	974	962	952	940	929	918	907	896	885	874	9237	8727
RTAA 340	lbs.	2789	2604	2611	2438	2433	2272	2248	2099	2077	1939	23510	22475
	kg	1265	1181	1184	1106	1104	1031	1020	952	942	880	10664	10195
RTAA 370	lbs.	2913	2624	2720	2449	2526	2275	2325	2094	2139	1926	23991	23026
	kg	1321	1190	1234	1111	1146	1032	1055	950	970	874	10882	10445
RTAA 400	lbs.	2936	2741	2737	2555	2537	2369	2330	2175	2139	1997	24516	23621
	kg	1332	1243	1242	1159	1151	1075	1057	987	970	906	11120	10714

- Notes:
1. Operating weight includes refrigerant and water.
 2. Shipping weight includes refrigerant.
 3. 70-125 ton units have 6 isolator locations. 130-215 ton units have 8 isolator locations. 240-400 ton units have 10 isolator locations.
 4. All weights \pm 3%.

70-125 TON

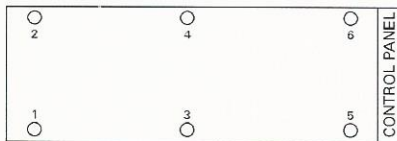

130-215 TON

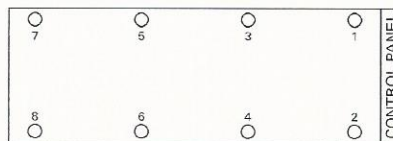

240-400 TON

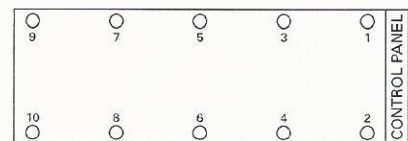



General Data

Table G-1 — General Data RTAA — 70-125 Ton

Size		70	80	90	100	110	125
Compressor							
Quantity		2	2	2	2	2	2
Nominal Size (1)	(Tons)	35/35	40/40	50/40	50/50	60/50	60/60
Evaporator							
Water Storage	(Gallons)	39.8	37.3	34.4	32.1	53.4	45.8
	(Liters)	150.6	143.1	130.2	121.5	202.11	173.4
Min. Flow	(GPM)	84	96	108	120	132	150
	(L/Sec)	5.3	6.1	6.8	7.6	8.3	9.5
Max. Flow	(GPM)	252	288	324	360	396	450
	(L/Sec)	15.9	18.2	20.4	22.7	25.0	28.4
Condenser							
Qty of Coils		4	4	4	4	4	4
Coil Length	(In)	156/156	156/156	168/156	168/168	204/168	204/204
Coil Height	(In)	42	42	42	42	42	42
Fins/Ft.		192	192	192	192	192	192
Number of Rows		2	2	2	2	2	2
Condenser Fans							
Quantity (1)		4/4	4/4	5/4	5/5	5/5	5/5
Diameter	(In)	30	30	30	30	30	30
Total Airflow	(CFM)	71750	71750	77640	83530	87505	91480
Nominal RPM		850	850	850	850	850	850
Tip Speed	(Ft/Min)	6675	6675	6675	6675	6675	6675
Motor HP (Ea)		1.0	1.0	1.0	1.0	1.0	1.0
Min Starting/Oper Ambient (2)							
Std Unit	(Deg F)	25	25	25	25	25	25
Low Ambient	(Deg F)	-10	-10	-10	-10	-10	-10
General Unit							
Refrigerant		HCFC-22	HCFC-22	HCFC-22	HCFC-22	HCFC-22	HCFC-22
No. of Independent Refrigerant Circuits		2	2	2	2	2	2
% Min. Load (3)		15	15	15	15	15	15
Refrigerant Charge (1)	(Lb)	58/58	61/61	73/61	73/73	98/73	98/98
	(Kg)	26/26	28/28	34/28	34/34	44/34	44/44
Oil Charge (1)	(Gallons)	2.5/2.5	2.5/2.5	3/2.5	3/3	3/3	3/3
	(Liters)	10.6/10.6	10.6/10.6	12.7/10.6	12.7/10.6	12.7/12.7	12.7/12.7

Table G-2 — General Data RTAA — 130-215 Ton

Size		130	140	155	170	185	200	215
Compressor								
Quantity		2	2	2	2	2	2	2
Nominal Size (1)	(Tons)	70/70	70/70	85/70	100/70	100/85	100/100	100/100
Evaporator								
Water Storage	(Gallons)	49	46	73	69	62	61	100
	(Liters)	184	175	277	261	234	231	378.5
Min. Flow	(GPM)	156	156	186	186	222	222	258
	(L/Sec)	9.8	9.8	11.7	11.7	14.0	14.0	16.27
Max. Flow	(GPM)	504	504	612	612	720	720	774
	(L/Sec)	31.8	31.8	38.6	38.6	45.4	45.4	48.82
Condenser								
Qty of Coils		4	4	4	4	4	4	4
Coil Length	(In)	214/214	214/214	240/214	240/214	240/240	240/240	240/240
Coil Height	(In)	42	42	42	42	42	42	42
Fins/Ft.		156	156	156	156	156	156	156
Number of Rows		3	3	3	3	3	3	3
Condenser Fans								
Quantity (1)		5/5	5/5	6/5	7/5	7/6	7/7	7/7
Diameter	(In)	30	30	30	30	30	30	30
Total Airflow	(CFM)	105,860	105,860	114,610	120,160	128,910	134,460	134,460
Nominal RPM		1140	1140	1140	1140	1140	1140	1140
Tip Speed	(Ft/Min)	8954	8954	8954	8954	8954	8954	8954
Motor HP (Ea)		1.5	1.5	1.5	1.5	1.5	1.5	1.5
Min Starting/Oper Ambient (2)								
Std Unit	(Deg F)	15	15	15	15	15	15	15
Low Ambient	(Deg F)	0	0	0	0	0	0	0
General Unit								
Refrigerant		HCFC-22	HCFC-22	HCFC-22	HCFC-22	HCFC-22	HCFC-22	HCFC-22
No. of Independent Refrigerant Circuits		2	2	2	2	2	2	2
% Min. Load (3)		10	10	10	10	10	10	10
Refrigerant Charge (1)	(Lb)	130/130	130/130	165/130	170/130	170/165	170/170	190/190
	(Kg)	59/59	59/59	75/59	77/59	77/75	77/77	86/86
Oil Charge (1)	(Gallons)	7/7	7/7	8/7	8/7	8/8	8/8	8/8
	(Liters)	27/27	27/27	30/27	30/27	30/30	30/30	30/30

Notes:

1. Data containing information on two circuits shown as follows: ckt1/ckt2
2. Minimum start-up/operating ambient based on a 5 mph wind across the condenser.
3. Percent minimum load is for total machine at 50 F ambient and 44 F LWT, not each individual circuit.