

Model number nomenclature



30RB E 070 6 4 - L 2 - - C
 30RB F 190 6 - 8 0 - - - L

30RB – Air-Cooled AquaSnap® Chiller

Design Series

Nominal Sizes

060	110	170	275	360*
070	120	190	300	390*
080	130	210	315*	
090	150	225	330*	
100	160	250	345*	

Voltage

1 – 575-3-60	5 – 208/230-3-60
2 – 380-3-60	6 – 460-3-60

Condenser Coil Options

- – Aluminum Fin/Copper Tube
- 0 – Copper Fin/Copper Tube
- 1 – Aluminum Pre-Coat Fin/Copper Tube
- 2 – Aluminum E-Coat Fin/Copper Tube
- 3 – Copper E-Coat Fin/Copper Tube
- 4 – Microchannel (MCHX)
- 5 – E-Coat, Microchannel (MCHX)

Hydronics Option

- – No Pump Installed
- 0 – Single Pump, 3 HP
- 1 – Single Pump, 5 HP
- 2 – Single Pump, 7.5 HP
- 3 – Single Pump, 10 HP
- 4 – Single Pump, 15 HP
- 6 – Dual Pump, 3 HP
- 7 – Dual Pump, 5 HP
- 8 – Dual Pump, 7.5 HP, Low Head
- 9 – Dual Pump, 7.5 HP, High Head
- B – Dual Pump, 10 HP
- C – Dual Pump, 15 HP
- F – Single Pump, 3 HP with VFD
- G – Single Pump, 5 HP with VFD
- H – Single Pump, 7.5 HP with VFD
- J – Single Pump, 10 HP with VFD
- K – Single Pump, 15 HP with VFD
- M – Dual Pump, 3 HP with VFD
- N – Dual Pump, 5 HP with VFD
- P – Dual Pump, 7.5 HP, Low Head with VFD
- T – Dual Pump, 7.5 HP, High Head with VFD
- Q – Dual Pump, 10 HP with VFD
- R – Dual Pump, 15 HP with VFD
- Z – Special order designation

**SEE NEXT PAGE
 FOR REMAINDER
 OF MODEL NUMBER
 NOMENCLATURE**

Cooler Options

- – Integral Cooler, CRN (Canada)
- 0 – Integral Cooler, Cooler Heater, CRN (Canada)
- 4 – Integral Cooler, Microchannel (MCHX), CRN (Canada)
- 5 – Integral Cooler, Cooler Heater, Microchannel (MCHX), CRN (Canada)
- G – Integral Cooler, no CRN
- H – Integral Cooler, Cooler Heater, no CRN
- K – Integral Cooler, Microchannel (MCHX), no CRN
- L – Integral Cooler, Cooler Heater, Microchannel (MCHX), no CRN
- R – Integral Cooler, Microchannel (MCHX), Heat Recovery, no CRN
- S – Integral Cooler, Cooler Heater, Microchannel (MCHX), Heat Recovery, no CRN
- T – Integral Cooler, Microchannel (MCHX), Heat Recovery, CRN (Canada)
- V – Integral Cooler, Cooler Heater, Microchannel (MCHX), Heat Recovery, CRN (Canada)

LEGEND

- CRN – Canadian Registration Number
- EMM – Energy Management Module
- GFI-CO – Ground Fault Interrupting Convenience Outlet
- LON – Local Operating Network
- SCCR – Short Circuit Current Rating
- VFD – Variable Frequency Device
- XL – Across-the-Line Start

*Refer to the Unit Sizes and Modular Combinations table below.
 NOTE: A "Z" in position 11 indicates a special order machine. Digits following do not correspond to tables.

Quality Assurance

Certified to ISO 9001

UNIT SIZES AND MODULAR COMBINATIONS

UNIT SIZE	NOMINAL TONS	NOMINAL kW	MODULE A	MODULE B
060	60	210	—	—
070	70	245	—	—
080	80	280	—	—
090	90	315	—	—
100	100	350	—	—
110	110	385	—	—
120	120	421	—	—
130	130	456	—	—
150	150	526	—	—
160	160	562	—	—
170	170	597	—	—

UNIT SIZE	NOMINAL TONS	NOMINAL kW	MODULE A	MODULE B
190	190	667	—	—
210	210	737	—	—
225	225	791	—	—
250	250	879	—	—
275	275	967	—	—
300	300	1055	—	—
315	315	1107	160	160
330	330	1160	170	160
345	345	1213	170	170
360	360	1266	190	170
390	390	1370	190	190

30RB E 070 6 4 - L 2 - - C

30RB F 190 6 - 8 0 - - - L

**SEE PREVIOUS PAGE
FOR REMAINDER
OF MODEL NUMBER
NOMENCLATURE**

Refrigeration Circuit Options

- - No Suction Line Insulation

- 0 - Suction Insulation
- 1 - Suction Service Valves
- 2 - Low Ambient Head Pressure Control Operation
- 3 - Suction Insulation, Suction Service Valves
- 4 - Suction Insulation, Low Ambient Head Pressure Control Operation
- 5 - Suction Service Valves, Low Ambient Head Pressure Control Operation
- 6 - Suction Insulation, Service Valves, Low Ambient Head Pressure Control Operation
- 7 - Minimum Load Control
- 8 - Suction Insulation, Minimum Load Control Operation
- 9 - Suction Service Valves, Minimum Load Control Operation
- B - Low Ambient Operation, Minimum Load Control Operation
- C - Suction Insulation, Suction Service Valves, Minimum Load Control Operation
- D - Suction Insulation, Low Ambient Head Pressure Control Operation, Minimum Load Control Operation
- F - Suction Service Valves, Low Ambient Head Pressure Control Operation, Minimum Load Control Operation
- G - Suction Insulation, Suction Service Valves, Low Ambient Head Pressure Control, Operation, Minimum Load Control Operation
- H - Suction Service Valves, High-Efficiency Variable Condenser Fans
- J - Suction Insulation, Suction Service Valve, High-Efficiency Variable Condenser Fans
- K - High-Efficiency Variable Condenser Fans
- L - Suction Insulation, High-Efficiency Variable Condenser Fans
- M - Suction Service Valves, High-Efficiency Variable Condenser Fans, Minimum Load Control Operation
- N - Suction Insulation, Suction Service Valve, High-Efficiency Variable Condenser Fans, Minimum Load Control Operation
- P - High-Efficiency Variable Condenser Fans, Minimum Load Control Operation
- Q - Suction Insulation, High-Efficiency Variable Condenser Fans, Minimum Load Control Operation

Packaging/Security Options

- L - No Packaging
- 0 - Skid
- 1 - Skid, Top Crate, Bag
- 3 - Coil Trim Panels
- 4 - Skid, Coil Trim Panels
- 5 - Skid, Top Crate, Bag, Coil Trim Panels
- 7 - Coil Trim Panels, Upper and Lower Grilles
- 8 - Skid, Coil Trim Panels, Upper and Lower Grilles
- 9 - Skid, Top Crate, Bag, Coil Trim Panels, Upper and Lower Grilles
- C - Trim Panels, Upper and Lower Grilles, Upper Hail Guards**
- D - Skid, Trim Panels, Upper and Lower Grilles, Upper Hail Guards
- F - Skid, Top Crate, Bag, Trim Panels, Upper and Lower Grilles, Upper Hail Guards
- H - Skid, Full End Covers
- J - Skid, Top Crate, Bag, Full End Covers
- K - Full End Covers

Controls/Communication Options

- - None

- 0 - EMM
- 1 - Remote Service Port, GFI-CO
- 2 - EMM, Remote Service Port, GFI-CO
- 3 - BACnet Communication
- 4 - BACnet Communication, EMM
- 5 - BACnet Communication, Remote Service Port, GFI-CO
- 6 - BACnet Communication, EMM, Remote Service Port, GFI-CO
- 7 - BACnet/Modbus Translator
- 8 - BACnet/Modbus Translator, EMM
- 9 - BACnet/Modbus Translator, Remote Service Port, GFI-CO
- E - BACnet/Modbus Translator, EMM, Remote Service Port, GFI-CO
- H - LON Translator
- J - LON Translator, EMM
- K - LON Translator, Remote Service Port, GFI-CO
- L - LON Translator, EMM, Remote Service Port, GFI-CO

Electrical/Low Sound/High SCCR Options

- - Single Point Power Connections, XL, Terminal Block
- 0 - Single Point Power Connections, XL, Terminal Block, High SCCR
- 3 - Dual Point Power Connections, XL, Terminal Block
- 4 - Dual Point Power Connections, XL, Terminal Block, High SCCR
- 7 - Single Point Power Connections, XL, Non-Fused Disconnect
- 8 - Single Point Power Connections, XL, Non-Fused Disconnect, High SCCR
- C - Dual Point Power Connections, XL, Non-Fused Disconnect
- D - Dual Point Power Connections, XL, Non-Fused Disconnect, High SCCR
- G - Single Point Power Connections, XL, Terminal Block, Cmpr Blankets
- H - Single Point Power Connections, XL, Terminal Block, Cmpr Blankets, High SCCR
- J - Dual Point Power Connections, XL, Terminal Block, Cmpr Blankets
- K - Dual Point Power Connections, XL, Terminal Block, Cmpr Blankets, High SCCR
- L - Single Point Power Connections, XL, Non-Fused Disconnect, Cmpr Blankets
- M - Single Point Power Connections, XL, Non-Fused Disconnect, Cmpr Blankets, High SCCR
- N - Dual Point Power Connections, XL, Non-Fused Disconnect, Cmpr Blankets
- P - Dual Point Power Connections, XL, Non-Fused Disconnect, Cmpr Blankets, High SCCR
- Q - Single Point Power Connections, XL, Terminal Block, Cmpr Blankets, Cmpr Enclosures
- R - Single Point Power Connections, XL, Terminal Block, Cmpr Blankets, Cmpr Enclosures, High SCCR
- S - Dual Point Power Connections, XL, Terminal Block, Cmpr Blankets, Cmpr Enclosures
- T - Dual Point Power Connections, XL, Terminal Block, Cmpr Blankets, Cmpr Enclosures, High SCCR
- V - Single Point Power Connections, XL, Non-Fused Disconnect, Cmpr Blankets, Cmpr Enclosures
- W - Single Point Power Connections, XL, Non-Fused Disconnect, Cmpr Blankets, Cmpr Enclosures, High SCCR
- X - Dual Point Power Connections, XL, Non-Fused Disconnect, Cmpr Blankets, Cmpr Enclosures
- Y - Dual Point Power Connections, XL, Non-Fused Disconnect, Cmpr Blankets, Cmpr Enclosures, High SCCR

LEGEND

- CRN - Canadian Registration Number
- EMM - Energy Management Module
- GFI-CO - Ground Fault Interrupting Convenience Outlet
- LON - Local Operating Network
- SCCR - Short Circuit Current Rating
- VFD - Variable Frequency Device
- XL - Across-the-Line Start

*Refer to the Unit Sizes and Modular Combinations table on page 4.
NOTE: A "Z" in position 11 indicates a special order machine. Digits following do not correspond to tables.

Dimensions



30RB060, 070 AIR-COOLED CHILLER

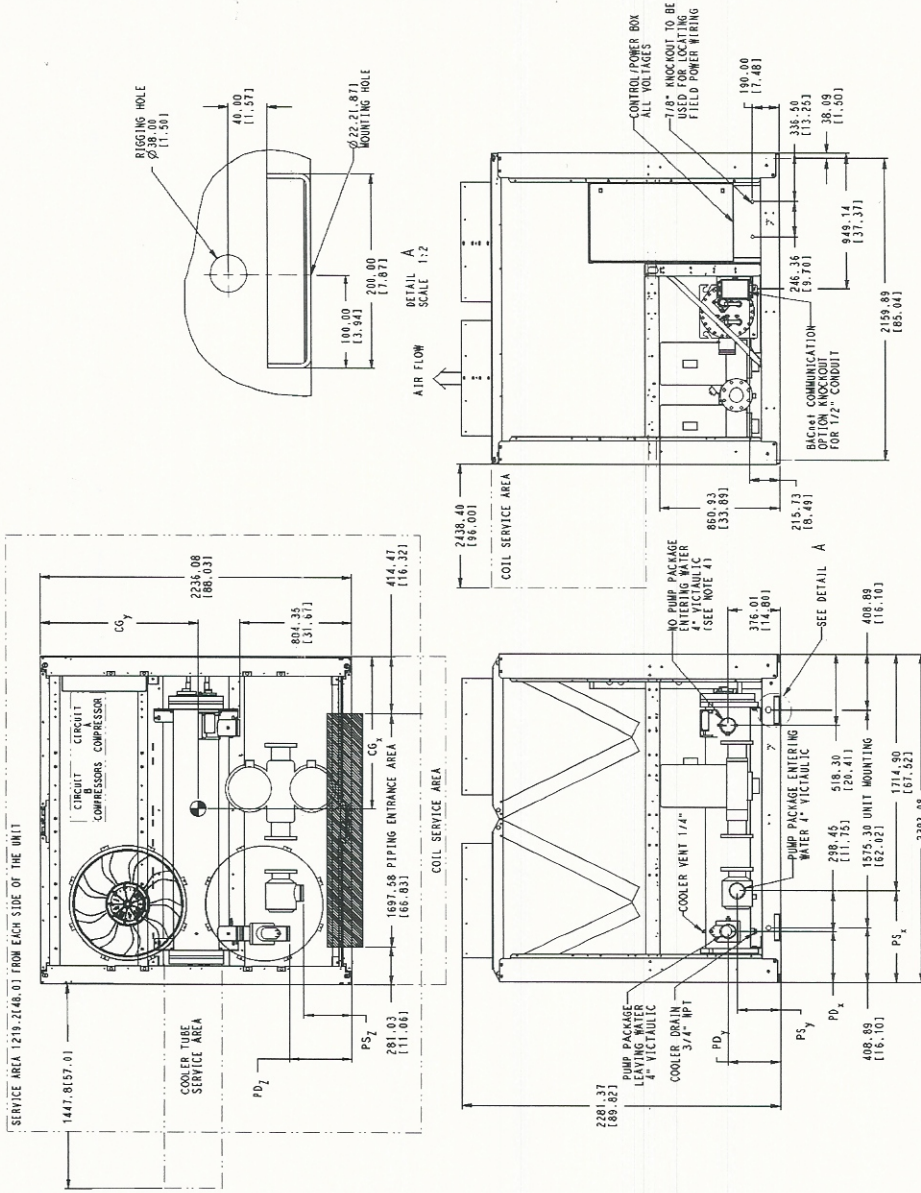

- NOTES:**
- Unit must have clearances as follows:
Top — Do not restrict.
Sides and End — 6' (1.8 m) from solid surface for air flow.
Side — 8' (2.4 m) required for coil service area.
All pumps have drains located at the bottom of volute for draining.
 - Temperature relief devices located on suction line, liquid line and filter drier of each circuit and have 1/4" flare connection.
 - Units without a pump package have the same leaving water connection, Y and Z dimensions (entering water) and Pump Discharge X dimensions as units with a pump package.
 - Dimensions are in mm [inches].

Model	Max. Weight		Max. Height		Max. Depth		Max. Width		Max. Length		Max. Volume	
	kg	lb	m	ft	m	ft	m	ft	m	ft	m ³	ft ³
30RB-060	4111	9069	4944	10733	3465	7545	2088	4586	1164	2552	103.3	2282
30RB-070	4317	9500	5150	11313	3878	8522	2181	4799	1193	2608	109.5	2417

MCHX — Microchannel Condenser Coil

Physical data



30RB060-300 — ENGLISH

UNIT 30RB	060	070	080	090	100	110	120	130	150
OPERATING WEIGHT (lb)*									
Al-Cu Condenser Coil	4,111	4,317	4,600	5,932	6,155	6,519	7,690	8,045	9,174
Cu-Cu Condenser Coil	4,593	4,799	5,082	6,656	6,879	7,243	8,534	9,010	10,139
MCHX Condenser Coil	3,783	3,978	4,267	5,449	5,663	6,027	7,119	7,402	8,517
REFRIGERANT TYPE									
Refrigerant Charge (lb)	R-410A, EXV Controlled System								
Std Coil, Ckt A/Ckt B/Ckt C	89.5/40.5/— 40/20/—	112/40.5/— 40/20/—	68.5/68.5/— 33/33/—	94/76/— 40/40/—	94/96/— 40/42/—	94/106/— 40/53/—	94/133/— 43/57/—	133/106/— 54/43/—	133/133/— 56/62/—
MCHX Coil, Ckt A/Ckt B/Ckt C									
COMPRESSORS									
Quantity	3	3	4	4	4	5	5	6	6
Speed (rpm)	Scroll, Hermetic 3500								
(Qty) Compressor Model Number Ckt A	(2) SH240	(2) SH295	(2) SH240	(2) SH295	(2) SH295	(2) SH295	(2) SH295	(3) SH295	(3) SH295
(Qty) Compressor Model Number Ckt B	(1) SH240	(1) SH240	(2) SH240	(2) SH240	(2) SH295	(3) SH240	(3) SH295	(3) SH240	(3) SH295
(Qty) Compressor Model Number Ckt C	N/A	N/A	N/A	N/A	N/A	N/A	N/A	N/A	N/A
Oil Charge (Pt, Ckt A/Ckt B/Ckt C)	26.2/13.1/—	29.2/13.1/—	26.2/26.2/—	29.2/26.2/—	29.2/29.2/—	29.2/39.4/—	29.2/43.8/—	43.8/39.4/—	43.8/43.8/—
No. Capacity Steps									
Standard	3	3	4	4	4	5	5	6	6
Optional (Maximum)	4	4	5	5	5	6	6	7	7
Minimum Capacity Step (%)									
Standard	33	29	25	22	25	18	20	15	17
Optional	22	19	16	14	18	12	14	10	12
Capacity (%)									
Ckt A	67	71	50	56	50	45	40	56	50
Ckt B	33	29	50	44	50	55	60	44	50
Ckt C	N/A	N/A	N/A	N/A	N/A	N/A	N/A	N/A	N/A
COOLER									
Weight (empty, lb)	715	715	856	856	856	970	970	970	1518
Net Fluid Volume (gal)	28.2	28.2	31.3	31.3	31.3	45.8	45.8	45.8	73.5
Maximum Refrigerant Pressure (psig)	445	445	445	445	445	445	445	445	445
Maximum Water-Side Pressure without Pumps (psig)	300	300	300	300	300	300	300	300	300
Maximum Water-Side Pressure with Pumps (psig)	150	150	150	150	150	150	150	150	150
COOLER WATER CONNECTIONS (in.)									
Inlet and Outlet, Victaulic	4	4	4	4	4	6	6	6	6
Drain (NPT)	3/4	3/4	3/4	3/4	3/4	3/4	3/4	3/4	3/4
CONDENSER FANS									
Shrouded Axial Type, Vertical Discharge									
Standard Low Noise Type									
Fan Speed (rpm) Standard	1140	1140	1140	1140	1140	1140	1140	1140	1140
No. Blades...Diameter (in.)	9...30	9...30	9...30	9...30	9...30	9...30	9...30	9...30	9...30
No. Fans (Ckt A/Ckt B/Ckt C)	3/1/—	3/1/—	2/2/—	3/3/—	3/3/—	3/3/—	3/4/—	4/4/—	4/4/—
Total Airflow (cfm)	49,600	49,600	49,600	74,400	74,400	74,400	86,800	99,200	99,200
CONDENSER COILS									
No. Coils (Ckt A/Ckt B/Ckt C)	3/1/—	3/1/—	2/2/—	3/3/—	3/3/—	3/3/—	3/4/—	4/4/—	4/4/—
Total Face Area (sq ft)	94	94	94	141	141	141	164	188	188
Max Working Refrigerant Pressure (psig)	656	656	656	656	656	656	656	656	656
OPTIONAL HEAT RECOVERY CONDENSER									
Flooded, Shell and Tube Type									
Weight (lb) (empty)	753	753	753	872	872	872	1236	1236	1236
Net Fluid Volume (gal)	8.0	8.0	8.0	10.0	10.0	10.0	15.1	15.1	15.1
Maximum Refrigerant Pressure (psig)	656	656	656	656	656	656	656	656	656
Maximum Water-Side Pressure (psig)	300	300	300	300	300	300	300	300	300
Water Connections (in.)									
Inlet and Outlet, Victaulic	3	3	3	3	3	3	5	5	5
Drain (NPT)	3/8	3/8	3/8	3/8	3/8	3/8	3/8	3/8	3/8
HYDRONIC MODULE (Optional)									
Pump	Pump(s) with pressure/temperature taps and combination valve. Single or Dual, 1800 or 3600 rpm								
CHASSIS DIMENSIONS (ft-in.)									
Length	7-11			11-10			15-9		
Width	7-4 ²⁵ / ₃₂								
Height	7-6 ⁷ / ₁₆								

LEGEND

- Al-Cu — Aluminum Fin/Copper Tube Condenser Coil
- Cu-Cu — Copper Fin/Copper Tube Condenser Coil
- EXV — Electronic Expansion Valve
- MCHX — Microchannel Condenser Coil
- N/A — Not Applicable

*Operating weight does not include any options.

NOTES:

1. 30RB chillers with Greenspeed® intelligence are not available in unit sizes 060 and 070.
2. No pumps are available for unit sizes 210-300.