



# Model Number Description

RTA C 140 4 U F0 N U A F N N 1 N X 1 T D C N N 0 N N 1 0 N N 0 EXN  
 1,2 3 4 5,6,7 8 9 10,11 12 13 14 15 16 17 18 19 20 21 22 23 24 25 26 27 28 29 30 31 32 33

## 140-500 Tons

### Digits 1, 2 – Unit model

RT Rotary chiller

### Digit 3 – Unit type

A Air cooled

### Digit 4 – Development sequence

C First sequence

### Digit 5, 6 & 7 – Nominal capacity

140 140 Nominal tons  
 155 155 Nominal tons  
 170 170 Nominal tons  
 185 185 Nominal tons  
 200 200 Nominal tons  
 225 225 Nominal tons  
 250 250 Nominal tons  
 275 275 Nominal tons  
 300 300 Nominal tons  
 350 350 Nominal tons  
 375 375 Nominal tons  
 400 400 Nominal tons  
 450 450 Nominal tons  
 500 500 Nominal tons

### Digit 8 – Unit voltage

A 200/60/3  
 C 230/60/3  
 J 380/60/3  
 D 400/50/3  
 4 460/60/3  
 5 575/60/3

### Digit 9 – Manufacturing location

U Water Chiller Business Unit, Pueblo, CO USA

### Digit 10, 11 – Design sequence

CO Factory Input

### Digit 12 – Unit basic configuration

N Standard efficiency/performance configuration  
 H High efficiency/performance configuration

### Digit 13 – Agency listing

N No agency listing  
 U UL/CUL listing

### Digit 14 – Pressure vessel code

A ASME pressure vessel code  
 L Chinese code

### Digit 15 – Evaporator application

F Standard (40-60 F) leaving temp  
 G Low (Less than 40 F) leaving temp  
 R Remote (40-60 F) leaving temp

### Digit 16 – Evaporator configuration

N Standard pass arrangement, insulated  
 P 3 pass arrangement, insulated

### Digit 17 – Condenser application

N Standard ambient range (25-115 F)  
 H High ambient capability (25-125 F)  
 L Low ambient capability (0-115 F)  
 W Wide ambient capability (0-125 F)

### Digit 18 – Condenser fin material

1 Standard aluminum slit fins  
 2 Copper fins  
 4 CompleteCoat epoxy coated fins

### Digit 19 – Condenser fan/motor configuration

N STD fans with ODP motors  
 T STD fans with TEAO motors  
 W Low noise fans

### Digit 20 – Compressor motor starter type

X Across-the-line starter  
 Y Wye-delta closed transition starter

### Digit 21 – Incoming power line connection

1 Single point power connection  
 2 Dual point power connection

### Digit 22 – Power line connection type

T Terminal block connection for incoming line(s)  
 D Non-fused disconnect switch(es) for incoming line(s)  
 C HACR rated circuit breaker(s) for incoming line(s)

### Digit 23 – Unit operator interface

D DynaView operator interface

### Digit 24 – Remote operator interface

N No remote interface  
 C Tracer Comm 3 interface  
 L LonTalk compatible (LCI-C) interface

### Digit 25 – Control input accessories/options

N No remote inputs  
 R Ext. evaporator leaving water setpoint  
 C Ext. current limit setpoint  
 B Ext. leaving water and current limit setpoint

### Digit 26 – Control output accessories/options

N No output options  
 A Alarm relay outputs  
 C Ice-making I/O  
 D Alarm relay outputs and ice-making I/O

### Digit 27 – Electrical protection options

0 No short circuit rating  
 5 10,000 Amp short circuit rating  
 4 35,000 Amp short circuit rating  
 6 65,000 Amp short circuit rating

### Digit 28 – Electrical accessories

N No electrical accessories  
 F Vapor proof flow switch – 150 psi  
 E Nema-1 flow switch – 150 psi

### Digit 29 – Control panel accessories

N No convenience outlet  
 A 15A 115V convenience outlet (60Hz)

### Digit 30 – Service valves

1 With suction service valves

### Digit 31 – Compressor sound attenuation option

0 No compressor sound attenuation  
 1 Factory installed compressor sound attenuation  
 2 Field installed compressor sound attenuation

### Digit 32 – Appearance options

N No appearance options  
 A Architectural louvered panels  
 C Half louvers  
 G Access guards  
 B Access guards and half louvers

### Digit 33 – Installation accessories

N No installation accessories  
 R Neoprene in shear unit isolators  
 F Flange kit for water connections  
 G Neoprene isolators and flange kit

### Digit 34 – Factory testing options

0 Standard functional test  
 C Customer-witnessed performance test with report  
 R Non-witnessed performance test with report

# Dimensions

- 140 Standard 50/60
- 155 Standard 50/60
- 170 Standard 50/60
- 140 High 50/60

Mounting Hole Diameter: 3/4" (19.1 mm)

Water Connection Diameter:

- 140 Standard 50/60Hz and 155 Standard 50/60Hz - 4" (102 mm)
- 140 High 50/60Hz and 170 Standard 50/60 Hz - 6" (152 mm)

Lifting Plate Dimensions: 7 1/2" x 6" (191mm x 152mm)

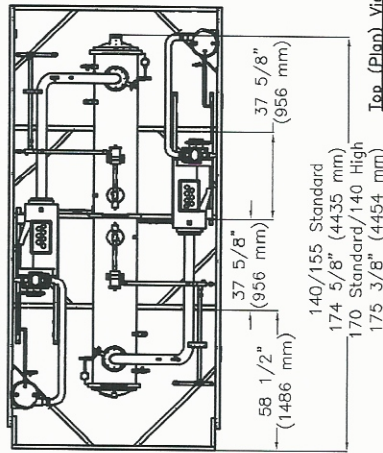

Top (Plan) View  
(With Coil Box Removed)

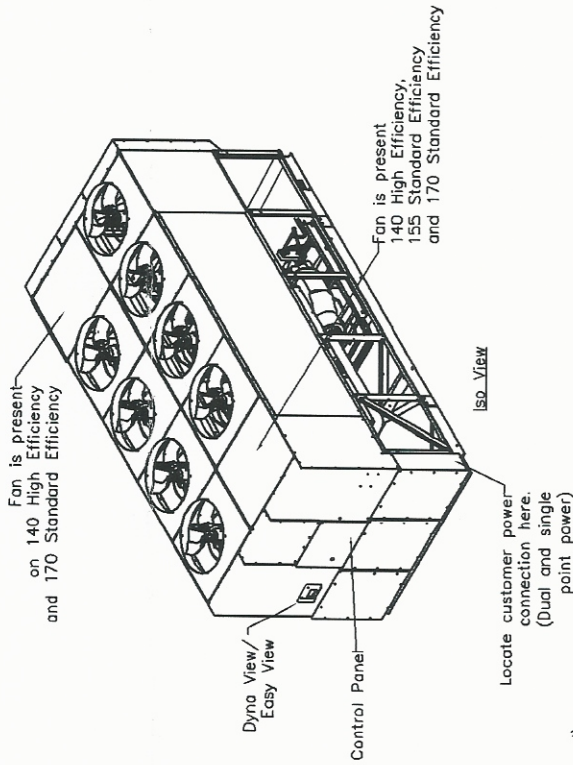

Isometric View

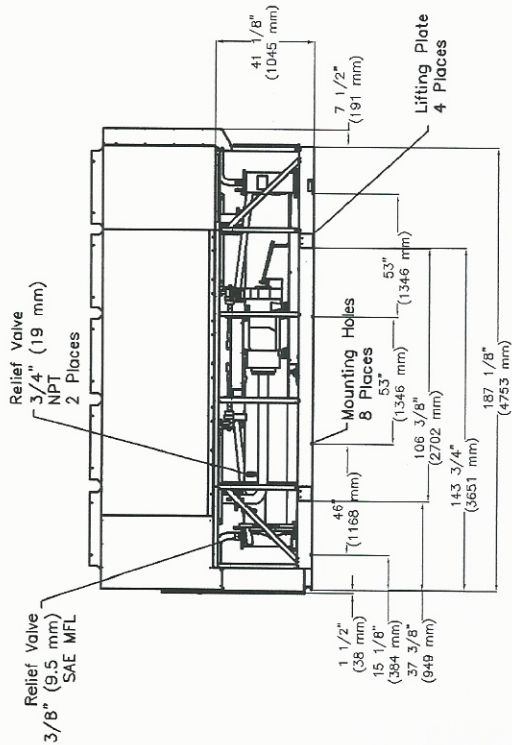

Side View

Minimum clearances are 4 feet to each side of the unit, 2 feet to the end opposite the control panel and National Electric Code Article 110-26 requirements for control panel clearances. Tube pull clearances are given in submittals and the Installation, Operation and Maintenance manual.

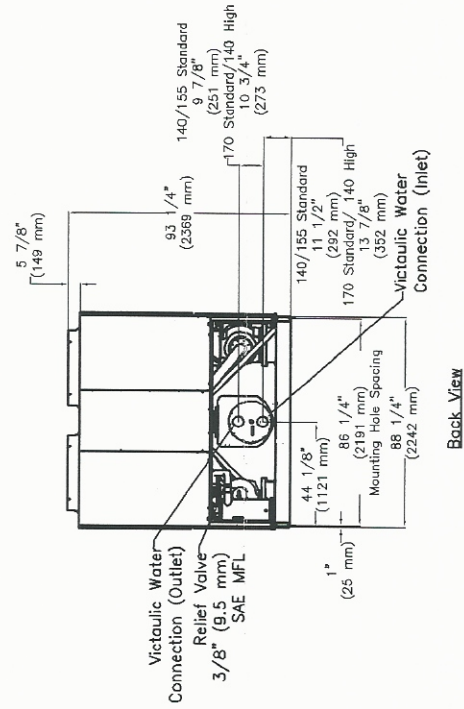

Back View

Note:  
Add 2" (51 mm) to overall width for lowered panels and coil protection.



# Weights

**Table W-1. Aluminum fin unit weights (60 Hz units)**

Unit Size	Units	Isolator Location										Operating Weight	Shipping Weight
		1	2	3	4	5	6	7	8	9	10		
RTAC 140 STD	lbs.	1384	1431	1363	1410	1340	1387	1317	1364	n/a	n/a	10995	10752
	kg	628	649	618	640	608	629	597	619	n/a	n/a	4987	4877
RTAC 140 HIGH	lbs.	1390	1437	1370	1418	1348	1395	1326	1373	n/a	n/a	11057	10780
	kg	630	652	622	643	611	633	601	623	n/a	n/a	5015	4890
RTAC 155 STD	lbs.	1389	1434	1369	1414	1346	1391	1323	1368	n/a	n/a	11034	10769
	kg	630	650	621	641	611	631	600	621	n/a	n/a	5005	4885
RTAC 155 HIGH	lbs.	1578	1630	1545	1598	1494	1547	1443	1496	n/a	n/a	12332	12038
	kg	716	740	701	725	678	702	655	679	n/a	n/a	5594	5460
RTAC 170 STD	lbs.	1391	1439	1372	1420	1350	1398	1328	1375	n/a	n/a	11073	10796
	kg	631	653	622	644	612	634	602	624	n/a	n/a	5023	4897
RTAC 170 HIGH	lbs.	1586	1641	1555	1610	1504	1559	1454	1509	n/a	n/a	12418	12098
	kg	719	744	705	730	682	707	660	685	n/a	n/a	5633	5488
RTAC 185 STD	lbs.	1642	1662	1608	1628	1553	1574	1499	1520	n/a	n/a	12685	12391
	kg	745	754	729	738	705	714	680	689	n/a	n/a	5754	5621
RTAC 185 HIGH	lbs.	1409	1513	1395	1499	1370	1475	1348	1452	1325	1429	14214	13897
	kg	639	686	633	680	622	669	611	659	601	648	6447	6304
RTAC 200 STD	lbs.	1663	1717	1636	1690	1593	1648	1551	1606	n/a	n/a	13104	12784
	kg	754	779	742	767	723	748	704	728	n/a	n/a	5944	5799
RTAC 200 HIGH	lbs.	1487	1537	1468	1519	1435	1486	1405	1456	1375	1425	14593	14247
	kg	674	697	666	689	651	674	637	660	623	646	6619	6462
RTAC 225 STD	lbs.	1483	1554	1466	1536	1435	1505	1406	1477	1378	1448	14687	14370
	kg	673	705	665	697	651	683	638	670	625	657	6662	6518
RTAC 225 HIGH	lbs.	1631	1674	1618	1661	1597	1640	1581	1624	1557	1601	16184	15838
	kg	740	759	734	753	724	744	717	737	706	726	7341	7184
RTAC 250 STD	lbs.	1510	1561	1493	1543	1461	1512	1433	1483	1404	1454	14853	14507
	kg	685	708	677	700	663	686	650	673	637	660	6737	6580
RTAC 250 HIGH	lbs.	1651	1676	1639	1664	1619	1644	1603	1629	1581	1607	16314	15968
	kg	749	760	743	755	734	746	727	739	717	729	7400	7243
RTAC 275 STD	lbs.	2168	1915	2124	1877	2072	1860	2052	1767	1976	1723	19536	18876
	kg	984	870	964	852	941	844	932	802	897	782	8869	8570
RTAC 275 HIGH	lbs.	2060	1819	2124	1877	2191	1950	2272	2083	2385	2183	20944	20266
	kg	935	826	964	852	995	885	1031	946	1083	991	9509	9201
RTAC 300 STD	lbs.	2163	1926	2188	1952	2220	1984	2256	2019	2324	2070	21103	20544
	kg	982	875	993	886	1008	901	1024	917	1055	940	9581	9327
RTAC 300 HIGH	lbs.	2382	2137	2381	2110	2347	2077	2309	2039	2274	2004	22060	22508
	kg	1081	970	1081	958	1066	943	1048	926	1032	910	10015	10219
RTAC 350 STD	lbs.	2134	1897	2203	1967	2291	2055	2389	2153	2526	2290	21904	21450
	kg	969	861	1000	893	1040	933	1085	977	1147	1040	9945	9738
RTAC 350 HIGH	lbs.	2637	2619	2525	2507	2442	2424	2389	2370	2284	2290	24487	23803
	kg	1197	1189	1146	1138	1109	1100	1085	1076	1037	1040	11117	10806
RTAC 400 STD	lbs.	2734	2748	2657	2636	2574	2554	2521	2500	2418	2412	25754	25074
	kg	1241	1248	1206	1197	1169	1160	1145	1135	1098	1095	11692	11383
RTAC 400 HIGH	lbs.	2734	2695	2763	2719	2787	2744	2812	2768	2836	2792	27650	26913
	kg	1241	1224	1254	1234	1265	1246	1277	1257	1288	1268	12553	12219
RTAC 450 STD	lbs.	2751	2751	2694	2694	2637	2637	2581	2581	2524	2524	26373	25678
	kg	1249	1249	1223	1223	1197	1197	1172	1172	1146	1146	11973	11658
RTAC 500 STD	lbs.	2753	2709	2777	2734	2802	2758	2826	2782	2850	2807	27798	27056
	kg	1250	1230	1261	1241	1272	1252	1283	1263	1294	1274	12620	12283

- Notes:  
 1. Operating weight includes refrigerant and water.  
 2. Shipping weight includes refrigerant.  
 3. All weights +/- 3%.

Unit Top (Plan) View

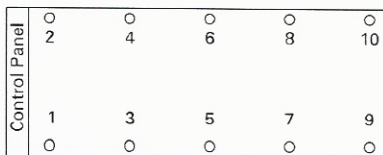

Unit Top (Plan) View

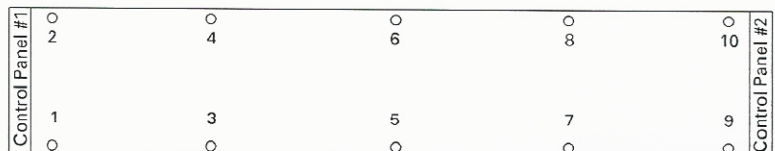



# General Data

**Table G-1. General data — 140-500 ton 60 Hz units - standard efficiency**

Size	140	155	170	185	200	225	250	275	300	350	400	450	500
Type	STD	STD	STD	STD	STD	STD	STD	STD	STD	STD	STD	STD	STD
<b>Compressor</b>													
Quantity (1)	2	2	2	2	2	2	2	3	3	3	4	4	4
Nominal size (tons) @ 60 Hz	70/70	85/70	85/85	100/85	100/100	120/100	120/120	85/100	100/100	120/100	100-100 / 100-100	120-120 / 100-100	120-120 / 120-120
<b>Evaporator</b>													
Water storage (gallons)	29	32	33	35	39	38	42	60	65	70	81	84	89
(liters)	111	121	127	134	146	145	158	229	245	264	306	316	337
<b>2 Pass arrangement</b>													
Minimum flow (gpm)	183	214	202	217	241	217	241	309	339	375	404	422	461
(L/s)	12	14	13	14	15	14	15	20	21	24	26	27	29
Maximum flow (gpm)	709	785	741	796	883	796	883	1134	1243	1374	1483	1548	1680
(L/s)	45	50	47	50	56	50	56	72	78	87	94	98	107
<b>3 Pass arrangement</b>													
Minimum flow (gpm)	129	143	135	145	161	145	161	206	226	250	270	282	307
(L/s)	8	9	9	9	10	9	10	13	14	16	17	18	19
Maximum flow (gpm)	473	523	494	531	589	531	589	756	829	916	989	1032	1127
(L/s)	30	33	31	33	37	33	37	48	52	58	62	65	71
<b>Condenser</b>													
Qty of coils	4	4	4	4	4	4	4	8	8	8	8	8	8
Coil length (inches)	156/156	180/156	180/180	216/180	216/216	252/216	252/252	180/108	216/108	252/108	216/216	252/216	252/252
(millimeters)	3962/3962	4572/3962	4572/4572	5486/4572	5486/5486	6401/5486	6401/6401	4572/2743	5486/2743	6401/4572	5486/5486	6401/5486	6401/6401
Coil height (inches)	42	42	42	42	42	42	42	42	42	42	42	42	42
(millimeters)	1067	1067	1067	1067	1067	1067	1067	1067	1067	1067	1067	1067	1067
Fins/Ft	192	192	192	192	192	192	192	192	192	192	192	192	192
Number of rows	3	3	3	3	3	3	3	3	3	3	3	3	3
<b>Condenser fans</b>													
Quantity (1)	4/4	5/4	5/5	6/5	6/6	7/6	7/7	10/6	12/6	14/6	12/12	14/12	14/14
Diameter (inches)	30	30	30	30	30	30	30	30	30	30	30	30	30
(millimeters)	762	762	762	762	762	762	762	762	762	762	762	762	762
Total airflow (cfm)	77000	84542	92087	101296	110506	119725	128946	147340	165766	184151	221016	239456	257991
(m <sup>3</sup> /hr)	130811	143623	156441	172086	187732	203394	219059	250307	281610	312843	375471	406797	438285
Nominal fan speed (rpm)	1140	1140	1140	1140	1140	1140	1140	1140	1140	1140	1140	1140	1140
(rps)	19	19	19	19	19	19	19	19	19	19	19	19	19
Tip speed (ft/min)	8954	8954	8954	8954	8954	8954	8954	8954	8954	8954	8954	8954	8954
(M/S)	45	45	45	45	45	45	45	45	45	45	45	45	45
<b>Minimum starting/operating ambient (2)</b>													
Standard unit (F)	25	25	25	25	25	25	25	25	25	25	25	25	25
(C)	-3.9	-3.9	-3.9	-3.9	-3.9	-3.9	-3.9	-3.9	-3.9	-3.9	-3.9	-3.9	-3.9
Low ambient (F)	0	0	0	0	0	0	0	0	0	0	0	0	0
(C)	-17.8	-17.8	-17.8	-17.8	-17.8	-17.8	-17.8	-17.8	-17.8	-17.8	-17.8	-17.8	-17.8
<b>General unit</b>													
Refrigerant	HFC-134a	HFC-134a	HFC-134a	HFC-134a	HFC-134a	HFC-134a	HFC-134a	HFC-134a	HFC-134a	HFC-134a	HFC-134a	HFC-134a	HFC-134a
No. of independent refrigerant circuits	2	2	2	2	2	2	2	2	2	2	2	2	2
% Minimum load	15	15	15	15	15	15	15	15	15	15	15	15	15
Refrigerant charge (1) (pounds)	165/165	175/165	175/175	215/210	215/215	225/215	225/225	365/200	415/200	460/200	415/415	460/415	460/460
(kilograms)	75/75	79/75	79/79	98/95	98/98	102/98	102/102	166/91	188/91	209/91	188/188	209/188	209/209
Oil charge (1) (gallons)	1.5/1.5	1.5/1.5	1.5/1.5	2.1/1.5	2.1/2.1	2.1/2.1	2.1/2.1	4.6/2.1	5.0/2.1	5.0/2.1	5.0/5.0	5.0/5.0	5.0/5.0
(liters)	6/6	6/6	6/6	6/8	8/8	8/8	8/8	17/8	19/8	19/8	19/19	19/19	19/19

**Notes:**

1. Data containing information on two circuits shown as follows: CKT 1/CKT 2
2. Minimum start-up/operating ambient based on a 5 mph wind across the condenser