

Water-Cooled Screw Compressor Chillers

WGS 130AW To WGS 190AW, Packaged Water-Cooled Chiller

WGS 130AA To WGS 190AA, Chiller with Remote Condenser

120 to 200 Tons, 420 to 700 kW

R-134A, 60 Hz



TABLE OF CONTENTS

INTRODUCTION	ELECTRICAL DATA, REMOTE CONDENSER
3	32
FEATURES AND BENEFITS	FIELD WIRING DIAGRAMS
437
UNIT CONTROL SYSTEM	PHYSICAL DATA
8	39
OPTIONAL REMOTE INTERFACE PANEL	WGS-AW, WATER-COOLED
939
BUILDING AUTOMATION SYSTEM (BAS) INTERFACE...10	WGS-AA REMOTE CONDENSER.....
40
SELECTION PROCEDURE	DIMENSIONAL DATA
13	41
AW WATER-COOLED	SOUND DATA
13	44
AA REMOTE CONDENSER.....	APPLICATION DATA
1445
WGS-AA WITH MATCHING A-C CONDENSERS.....16	REMOTE CONDENSER REFRIGERANT PIPING.....
49
PERFORMANCE ADJUSTMENT FACTORS	OPTIONAL FEATURES
17	52
PERFORMANCE DATA	PRODUCT SPECIFICATIONS
19	55
PRESSURE DROPS	WATER-COOLED SCREW COMPRESSOR CHILLER
26	55
ELECTRICAL DATA, WATER-COOLED	SCREW COMPRESSOR CHILLER WITH REMOTE CONDENSER
2861



Document:	CAT WGS-1
Issue Date:	July 2008
Revision Date:	November 2008
Replaces:	June 2008
McQuayTools PDC version:	7.8x

The ratings in this catalog are consistent with the McQuayTools™ selection program version shown above.
For the most up-to-date information, please go to www.mcquay.com.

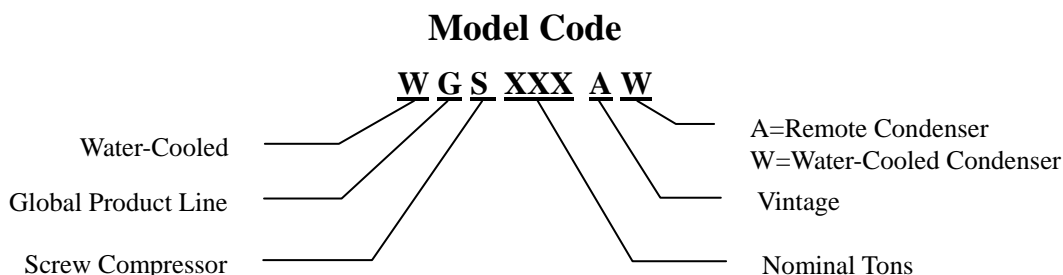

Manufactured in an ISO Certified Facility

Illustrations and data cover the McQuay International product at the time of publication and we reserve the right to make changes in design and construction at anytime without notice. Units with remote condensers (Models AA) are not included in the scope of ARI certification. Unit controllers are LONMARK certified with an optional LONWORKS communications module. ®™ The following are trademarks or registered trademarks of their respective companies: BACnet from ASHRAE; LONMARK, LonTalk and LONWORKS and the LONMARK logo are managed, granted, and used by LONMARK International under a license granted by Echelon Corporation; Modbus from Schneider Electric; FanTrol, MicroTech II, Open Choices™, and SpeedTrol from McQuay International.

Introduction

The WGS water-cooled screw chillers continue McQuay's legacy of high quality, high efficiency, latest technology and quiet operation. Our model WGS units utilize an advanced compressor design utilizing R-134a refrigerant. Superior control is provided by the innovative MicroTech II[®] family of controllers. Interface with your building's automation system with the McQuay Open Choices[™] feature using factory-installed LONTALK[®], BACnet[®] or Modbus[®] communication modules. The WGS chiller continues to be the ONLY screw compressor chiller on the market with superior solid state starters as standard equipment. Perhaps most importantly, they continue McQuay's reputation for quiet operation making these chillers "building friendly".

The WGS solid state starters provide stepless acceleration, controlled deceleration, and advanced motor/compressor protection features. McQuay is the only manufacturer to provide this advanced technology as standard equipment on water-cooled screw chillers.

SUPERIOR EFFICIENCY

- Single-rotor compressor design
- Electronic expansion valve control
- High efficiency single-pass direct expansion evaporator
- All models exceed ASHRAE 90.1-October 2001 efficiency standard

QUIET OPERATION

- Single rotor design is inherently quiet
- Virtually vibration-free operation

OUTSTANDING RELIABILITY

- Independent refrigerant circuits
- Rugged compressor design
- Solid state starters for smooth acceleration and deceleration
- Advanced composite gaterotor material
- Multiple compressors with independent controllers
- Proactive control logic
- Full factory-run-testing to optimize trouble-free operation
- Factory authorized startup

SUPERIOR CONTROL LOGIC

- Easy to read 4-line by 20-character LCD display
- Supports standard protocols: LonTalk[®], BACnet[®] or Modbus[®]
- Superior reliability under extreme operating conditions

Features and Benefits

Low Operating Costs -- High Efficiency Operation

The McQuay AGS chiller uses the McQuay screw compressor design and large heat exchangers for maximum heat transfer. Generous heat transfer area translates into lower compressor pumping head and improved efficiency. A single pass, direct expansion evaporator provides superior performance by providing true counterflow heat transfer and low refrigerant and water pressure drops.



Superior Motor Control--Solid State Starters--Our Standard Offering

AGS chillers are the only units available that provide the superior motor control of solid-state starters as standard. The benefits are impressive.

A primary benefit is that the compressors are started slowly, requiring from three to seven seconds to go from a stop to full-speed condition. This reduces vibration and compressor stresses for longer life. If liquid refrigerant is present at the compressor intake, the slow acceleration easily moves the liquid out without damaging the compressor.

Perhaps more important is the slow deceleration when operation is no longer required. The traditional jerking and backward rotation allowed by conventional starters is eliminated with solid-state starters. Again, extended compressor life can be expected.

Another great benefit is the superior electrical system monitoring. In the event of main electrical power problems, the solid-state starters tightly monitor the power quality and make protective decisions to help prevent compressor motor damage. This includes the functions of phase and under/over voltage protection and ground fault protection.

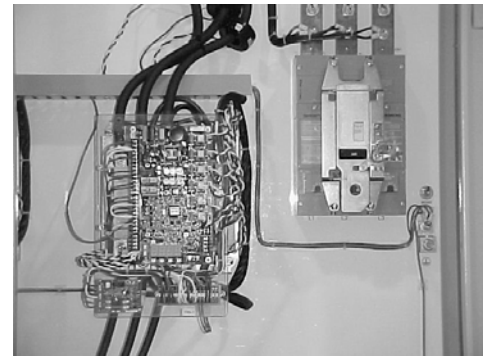

Quiet Operation – “Building Friendly”

Another feature that sets the McQuay chiller apart from other screw chillers is its low operating sound levels. The primary reason for quiet operation is the compressor design itself. McQuay’s compressor design continues the philosophy of a single main rotor with two interlocked rotating gaterotors with gas flow velocities and subsequent noise levels among the lowest available. This compressor design is unique and proven by years of excellent service. Low sound levels allow greater flexibility in unit placement near a building.

AGS chiller sound data is published in this catalog for an easy comparison with other offerings. See page 44. Although others claim low sound levels, it is difficult to find their published sound data to support their claims.

R-134a Refrigerant for Sustainable Performance

All McQuay WGS chillers use R-134a refrigerant. It has no ozone depletion potential and is considered a solution to refrigerant environmental issues. It is environmentally safe and does not have a phase-out date. It has the best toxicity and flame propagation rating under ASHRAE Std 34 safety standard.

User Friendly MicroTech II® Controls

The MicroTech II unit controller provides an easy-to-use control environment. The control logic is designed to provide maximum efficiency, to continue operation in unusual operating conditions, and to provide a history of unit operation.

Perhaps the greatest benefit is McQuay's Open Choice feature, which allows easy integration with your building automation system of choice using LONTALK, BACnet or Modbus standard protocols. See the complete control description on page 8 in this catalog.

MicroTech II control uses distributed control, with each refrigerant circuit having a dedicated microprocessor. Distributed control architecture means that if any compressor controller is unavailable, the remaining controllers are unaffected and their compressors will continue to operate. This feature can greatly enhance chiller reliability.



Installation Savings for Retrofit Applications

All WGS chillers will fit through a 36-inch-wide door (without sound enclosure). This attribute can mean considerable installation cost savings on many retrofit applications that may have access problems.

Water-Cooled Condensers (AW Models)

A separate water-cooled condenser is provided for each refrigerant circuit. They are cleanable, shell-and-tube type with water in the tubes and refrigerant in the shell side. Each condenser circuit is capable of holding the circuit's refrigerant charge and each circuit has its own charging and relief valves. They are designed, constructed and tested in accordance with the ASME Pressure Vessel Code. Optional condenser water manifolds (as shown on the right) are available to provide a single piping connection to the inlet and outlet.

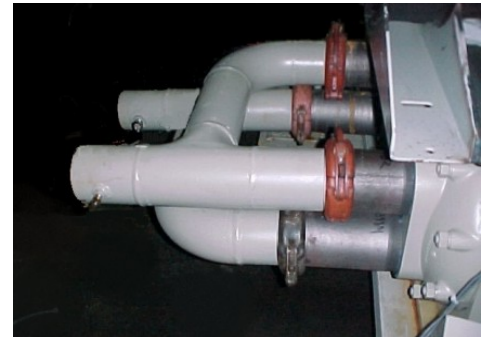

The condensers are constructed with a carbon steel shell and seamless, integrally finned, high efficiency copper tubes, roller expanded into steel tubesheets. The water heads are removable and have vent and drain connections at each end. Also included is a liquid shutoff valve, purge valve, and relief valve per ANSI/ASHRAE Pressure Vessel Code, Section VIII.

Water side working pressure is 225 psi (1551 kPa); refrigerant side is 350 psi (2413 kPa).

Remote Condenser (Model AA)

The WGS-AA chillers are designed for use with properly sized and configured remote air-cooled or evaporative condensers. This feature increases the units' application flexibility. The use of an evaporative condenser can give the operating economy of a water-cooled unit at a lower cost than using a cooling tower.

Figure 1, WGS-AA Unit for Remote Condensers

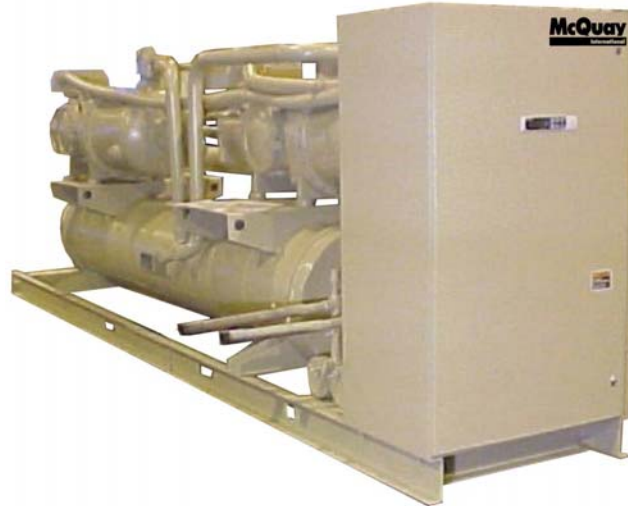

Figure 2, McQuay Remote Air-Cooled Condenser



The McQuay ACH/ACX/ACL air-cooled condensers are available with single or double row, vertical discharge fans and are fully described and rated in *Catalog A-C Cond.* The condensers are packed with features offering tangible benefits to owners. The ACX and ACL series are designed for quieter operation than the standard ACH series.

Product features include:

- Direct drive fan motors at 1140 RPM or 830 RPM for lower sound levels
- Patented floating tube design to eliminate tube sheet leaks
- High efficiency coil and fan motor design
- Internal baffles between all fan cells
- Weatherproof control panel with door mounted disconnect switch
- G90 painted galvanized steel cabinets with optional painted or aluminum construction
- Single-point power connection
- Independent fusing and contactors for each fan motor
- Integral pre-piped subcooler circuit
- Head pressure control with either optional condenser pressure switches or through the MicroTech II controller.

Part Load Efficiencies

Part load efficiencies and Integrated Part Load Values (IPLV) for AW units are calculated according to the requirements of the latest ARI Standard 550/590-98 and meet or exceed ASHRAE Efficiency Standard 90.1. Since most air conditioning systems operate at less than design full load most of the time, IPLV is an excellent method for comparing the efficiencies of chillers.

ARI Certification

The ARI certification program does not include units with remote condenser and they are not certified. However, the rating and testing procedures follow the ARI standard where possible.

Noise

All McQuay WGS chillers are equipped with hermetic screw compressors with inherently low sound levels. For sensitive locations, optional acoustical compressor enclosures will further reduce sound levels. See page 44 for sound data.

Electrical Control Center

The WGS has a novel two-section electrical panel. The outer section has three MicroTech II microprocessor controllers providing operating and equipment protection controls plus transformers, terminal boards and operational switches. Opening this panel section reveals the inside power section with two solid state motor starters, fuses, two circuit breakers, and power block(s) or disconnect switch (switches), depending on options selected.

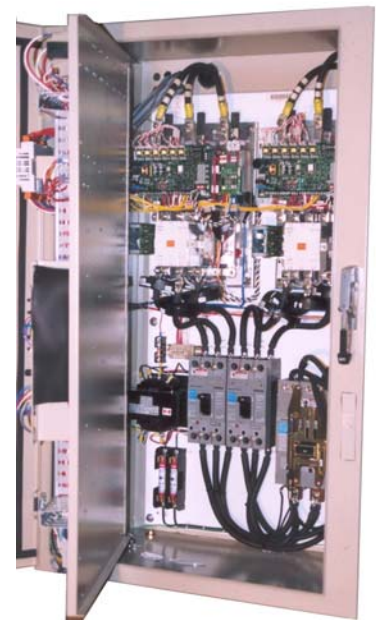

Electronic Expansion Valve

The WGS chiller is equipped with the most advanced means of refrigerant flow control available. An electronic expansion valve coupled with a MicroTech II unit controller provides excellent operating efficiencies both at full and part load operation.

Unlike conventional thermal expansion valves which require a large pressure drop across the valve and result in higher condenser head pressure, the electronic valve does not need a large pressure drop across it to operate effectively. During part load operation, the electronic valve allows the system to operate at a lower condensing pressure, minimizes suction line superheat, and provides more stable system operation. Unit efficiencies can be dramatically improved. The electronic expansion valve for the GeneSys chiller line provides precise control with a quick response time.

Figure 3, Schematic Piping Diagram (One of Two Circuits)

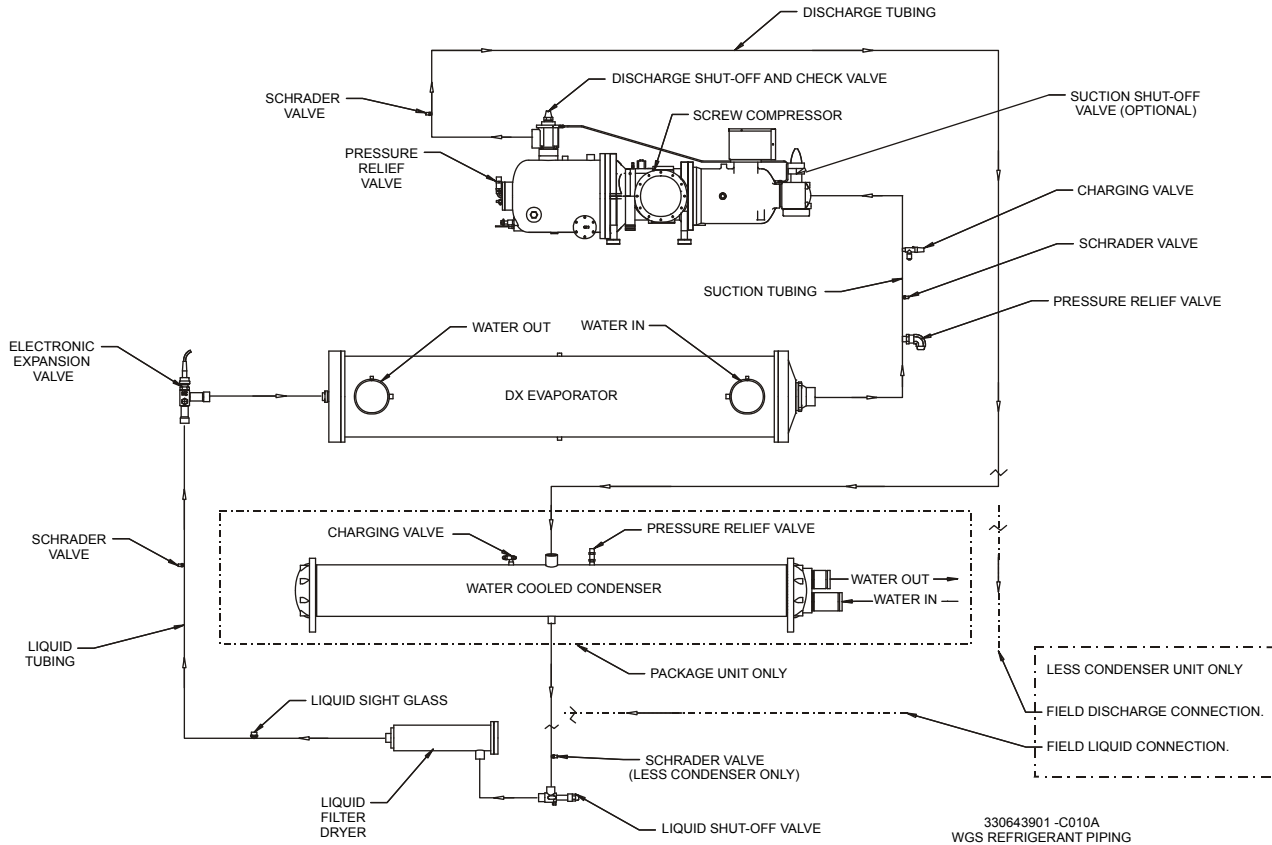

Note: Vents and drains are located on each condenser head and on the top and bottom of the evaporator.

Unit Control System

The MicroTech II control system uses three advanced microprocessors, providing a user-friendly environment for the operator. The control logic is designed to provide maximum efficiency, to continue proper operation in unusual operating conditions and to provide a history of operating conditions.

- Distributed control architecture enhances unit reliability. A unit controller looks after parameters common to the entire chiller. Each compressor circuit has its own microprocessor controller so that if one circuit controller becomes unavailable, the other circuit is unaffected and will continue to run.
- A logic control system employed in the WGS screw chiller optimizes the suction line superheat and the positioning of the electronic expansion valve at all compressor capacities. Using the available intelligent cooling tower or air-cooled condenser control contributes to optimizing unit efficiency at all operating conditions.
- Complete instrumentation with state-of-the-art pressure transducers and temperature sensors provide unparalleled operator information and diagnostic ability.

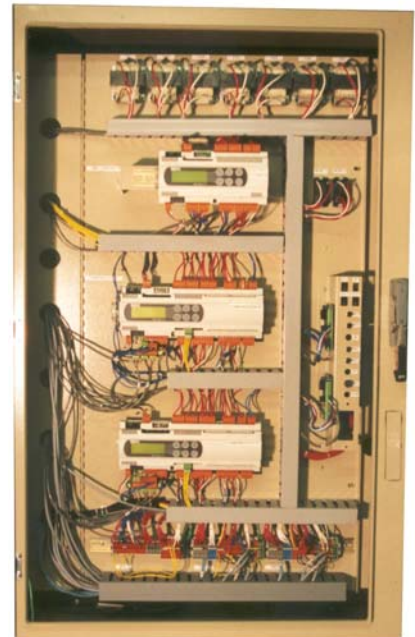

- Superior discharge pressure control on remote condenser applications maximizes unit efficiency by determining optimum condenser fan operation. As many as 6 stages of heat rejection per circuit are provided.
- MicroTech II controllers have a proactive limit control feature that keeps the unit online when selected operating parameters start to exceed design settings. For example, if the discharge pressure starts to climb for some reason, rather than shutting down the unit, the control will inhibit capacity increase to prevent further heat rejection to the condenser. If the pressure continues to climb, the control will unload the compressor in an attempt to keep the pressure within bounds. Either of these actions will illuminate a signal on the controller and also be recorded in the fault register. If these two defenses fail, and the pressure still continues to rise, the control will shut the compressor off at the shut off setpoint.
- The operator interface is through a 4-line by-20 character/line liquid crystal display and a 6-key keypad mounted on the unit controller. Its layout is shown below.

Figure 4, Keypad and Display in MENU Mode

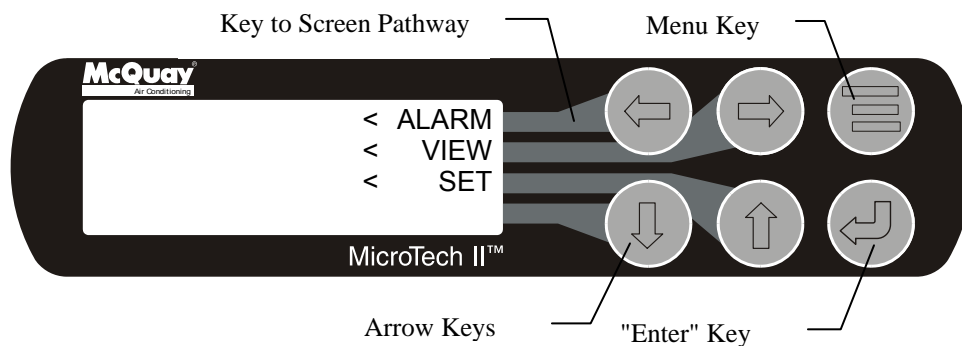

Optional Remote Interface Panel

In addition to the unit-mounted LCD user interface provided with MicroTech II controller, the WGZ chiller can be individually equipped with a remote user interface. It provides convenient access to unit diagnostics and control adjustments, without having to access your mechanical rooms. A separate remote panel is required for each chiller on a job site.

Each remote user interface is similar to its unit-mounted counterpart and offers the same functionality, including:

- Touch sensitive keypad with a 4 line by 20-character display format.
- Digital display of messages in English language.
- All operating conditions, system alarms, control parameters and schedules are monitored.

Features

- Can be wired up to 1,640 feet (500 meters) from the unit for flexibility in placing each remote user interface within your building.
- The main control is isolated from the remote user interface wiring so that wiring problems are less likely to damage the unit user interface.

Benefits

- Allows you to access the user interface for each unit from one location, inside the building.
- Users need to learn one format because the remote user interface is identical to the unit-mounted version.
- No additional field commissioning is required for the remote user interface.
- Can be retrofit after unit installation.
- All the BAS interface options are still available with the remote interface panel.

Cable and Wiring Recommendations

- No more than 1,640 feet (500 meters) of wiring can be used to connect the remote user interface to the unit.
- Power: AWG 22 twisted pair cable.
- Communications: Belden 9841 or equal AWG 22 twisted pair.

Figure 5, Remote Interface Panel Dimensions

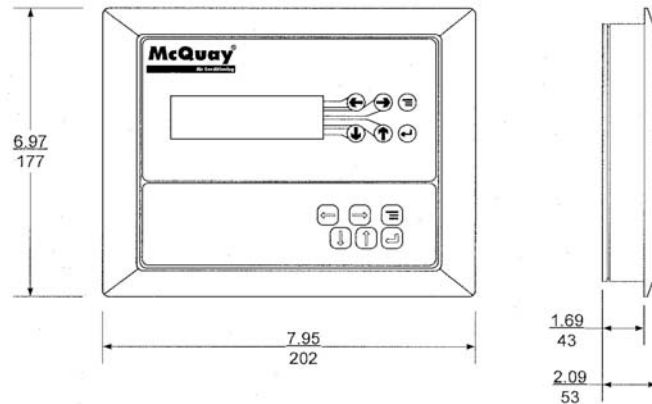
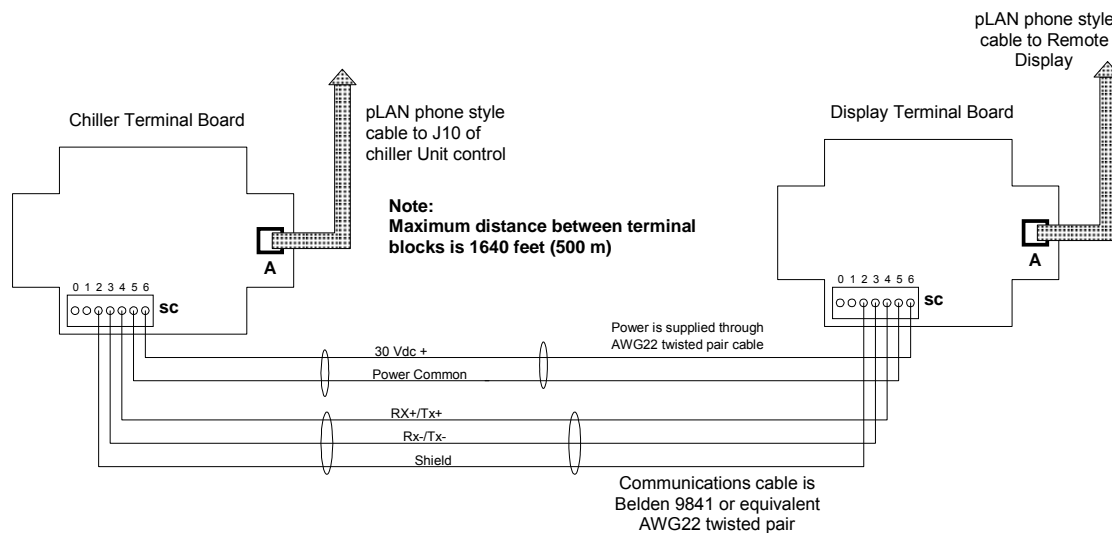

Figure 6, Remote User Interface Wiring Diagram



Building Automation System (BAS) Interface

All MicroTech II controllers are capable of BAS communications, providing seamless integration and comprehensive monitoring, control, and two-way data exchange with industry standard protocols such as LONMARK®, Modbus® or BACnet®.

Open Choice Benefits

- Easy to integrate into your building automation system of choice
- Factory-installed and tested communication module
- Comprehensive point list for system integration, equipment monitoring and alarm notification
- Provides efficient equipment operation
- Owner/designer can select the BAS that best meets building requirements
- Comprehensive data exchange

Integration Made Easy

McQuay unit controllers strictly conform to the interoperability guidelines of the LONMARK® Interoperability Association and the BACnet Manufacturers Association. The control system has received:

- LONMARK certification with optional LONWORKS communication module

- BACnet certification pending

Protocol Options

- BACnet MS/TP
- BACnet IP
- BACnet Ethernet
- LONWORKS® (FTT-10A)
- Modbus RTU

The BAS communication module can be ordered with a chiller and factory-mounted or can be field-mounted at any time after the chiller unit is installed.

Table 1, Available BAS Parameters

Types: A = Analog, I= Integer, D= Digital

I/O: I = Input only, O = Output only , I/O = Input/Output

Bold points are setpoints that can be changed from the BAS.

Type	Index	I/O	Description	LONWORKS	BACnet	Modbus
ANALOG						
A	1	I/O	Network Cool LWT set point	x	x	x
A	2	O	Active LWT(Leaving Water Temp) set point	x	x	x
A	3	I	Network Capacity Limit	x	x	x
A	4	O	Evap EWT (Entering Water Temp)	x	x	x
A	5	I/O	Network Heat set point	x	x	x
A	6	O	Evap LWT	x	x	x
A	7	O	Cond EWT	x	x	x
A	8	O	Cond LWT	x	x	x
A	10	O	Unit capacity (%)	x	x	x
A	11	I	Network Cool LWT set point default	x		
A	12	I	Network Heat set point default	x		
A	15	O	Suction Temp	x	x	x
A	16	O	Evap sat temp	x	x	x
A	17	O	Evap pressure	x	x	x
A	19	O	Discharge Temp	x	x	x
A	20	O	Cond sat temp	x	x	x
A	21	O	Cond pressure	x	x	x
A	37	O	Liquid line saturated temp	x	x	x
A	38	O	Liquid line pressure	x	x	x
A	39	O	OAT (Outside Air Temp)	x	x	x
A	42	O	Active Capacity Limit	x	x	x
A	50	I/O	Network Ice LWT set point	x	x	x
INTEGER						
I	1	O	Active alarms 1	x	x	x
I	2	O	Active alarms 2	x	x	x
I	3	O	Active alarms 3	x	x	x
I	4	O	Active alarms 4	x	x	x
I	5	O	Active alarms 5	x	x	x
I	6	O	Active alarms 6	x	x	x
I	7	O	Active alarms 7	x	x	x
I	8	O	Active alarms 8	x	x	x
I	9	O	Active alarms 9	x	x	x
I	10	O	Active alarms 10	x	x	x
I	11	O	Active alarms 11	x	x	x
I	12	O	Active alarms 12	x	x	x
I	13	O	Active alarms 13	x	x	x
I	14	O	Active alarms 14	x	x	x
I	15	O	Active alarms 15	x	x	x
I	16	O	Active alarms 16	x	x	x
I	17	I	Network chiller mode set point	x	x	x
I	18	O	LON Chiller run mode	x	x	x

Continued on next page.

Table Continued

Type	Index	I/O	Description	LONworks	BACnet	Modbus
I	19	O	Active unit mode	x	x	x
I	20	I	Network Capacity Limit default set point	x		
I	21	I	Network chiller mode default set point	x		
I	28	O	Unit model type, refrigerant	x	x	x
I	29	O	Unit language	x	x	x
I	30	O	Unit software version	x	x	x
I	32	I	Compressor select	x	x	x
I	35	I/O	Clock year		x	x
I	36	I/O	Clock month		x	x
I	37	I/O	Clock day of month		x	x
I	38	I/O	Clock day of week		x	x
I	39	I/O	Clock hours		x	x
I	40	I/O	Clock minutes		x	x
I	45	O	Compressor starts	x	x	x
I	46	O	Compressor run hours	x	x	x
DIGITAL						
D	1	I/O	Network chiller enable set point	x	x	x
D	2	O	Chiller enable status	x	x	x
D	3	O	Active alarm indicator	x	x	x
D	4	O	Chiller run enabled	x	x	x
D	5	O	Chiller local control	x	x	x
D	6	O	Chiller capacity limited	x	x	x
D	7	O	Evaporator Water Flow	x	x	x
D	8	O	Condenser Water Flow	x	x	x
D	9	I	Network chiller enable default set point	x		
D	10	I	Ignore network defaults	x		
D	12	I	Set clock command		x	x
D	24	I	Network clear alarm signal	x	x	x
D	29	O	Evaporator pump	x	x	x
D	31	O	Condenser pump	x	x	x

Figure 7, Side View of a WGS-AW Chiller with Optional Condenser Water Manifolds

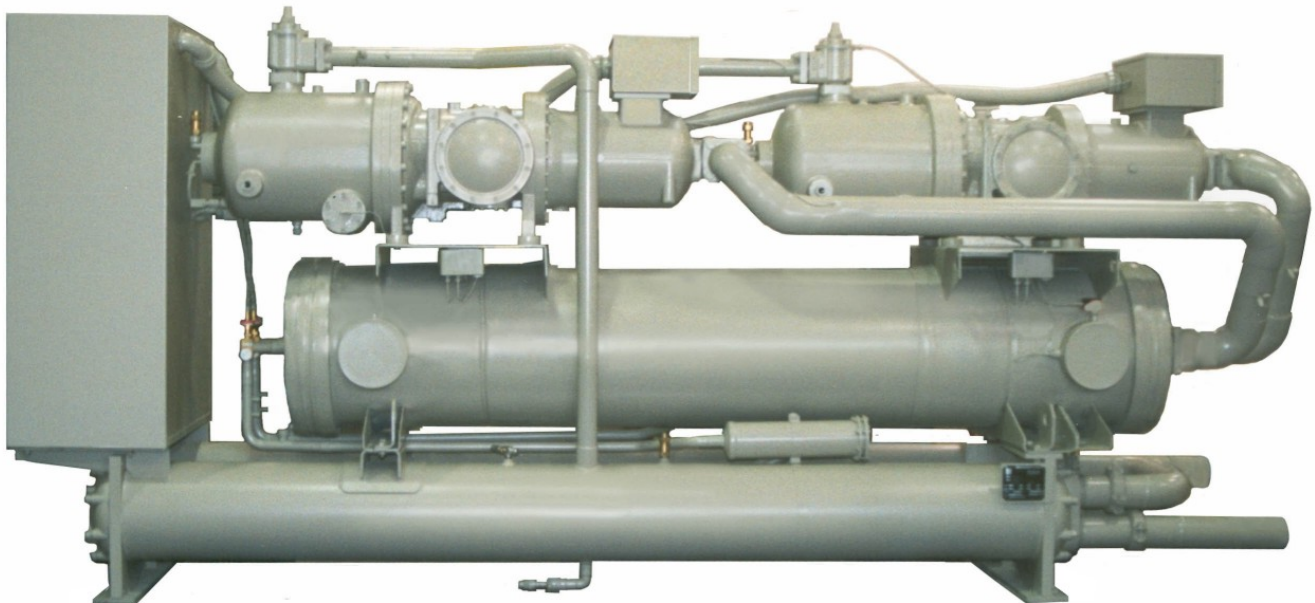

Selection Procedure

AW Water-Cooled

1. Ratings are based on, and certified in accordance with, ARI Standard 550/590-2003.
2. Ratings in Table 8 through Table 12 can be interpolated for any chiller water temperature between 40°F and 50°F (4.4°C and 10.0°C), but cannot be extrapolated.
3. Chilled water quantities: ratings are based on a 10-degree F (5.6-degree C) chilled water range (2.4 gpm/ton) and can be used for a Delta-T range of 6 to 16 degrees F (3.3 to 8.8 degrees C) by applying performance adjustments from Table 5.
4. Figure 8 on page 26 gives the evaporator water pressure drop data. Water flow rates should be maintained within the limits shown on the bottom of the page.
5. Ratings are based on 0.0001 fouling factor for the evaporator. For other fouling factors, multiply ratings by evaporator factors from Table 5. For applications using a glycol solution, see Table 2 or Table 3.
6. Ratings are based on condenser flow of 3 gpm/ton (10 degree F, 5.6 degree C Delta-T) and 0.00025 fouling factor. Corrections for other conditions are in Table 6.
7. Figure 9 on page 27 gives the condenser water pressure drop data. Water flow rates should be maintained within the limits shown on the bottom of the page.

Selection Procedure

Knowing the required chiller capacity in tons, the leaving water temperature, and either the chilled water temperature range (Delta T) or the flow, determine the unknown quantity using the formula:

$$\text{Tons} = \frac{\text{GPM} \times \text{Delta } T}{24} \quad (\text{water only})$$

Knowing the required chiller capacity (tons), the entering condenser water temperature, and either the condenser water temperature range-delta T, or the GPM, determine the unknown quantity using the formula:

$$\text{Condenser GPM} = \frac{\text{THR}}{500 \times \text{Delta - T Cond.}} = \frac{\text{Nominal Tons Cooling Capacity} \times 30}{\text{Condenser Water Range}}$$

With the above data, the appropriate unit can be selected from Table 8 and Table 9. Correct the capacity and power from Table 5 and Table 6 if conditions are other than standard as described above. Pressure drop for evaporators and condensers can be found in Figure 8 and Figure 9.

Sample Selection

Given: Capacity of 170 tons, cool 340 GPM of water from 56°F to 44°F with 510 gpm condenser water at 85°F. Fouling factor of 0.0001 in the evaporator and 0.00025 in the condenser.

Find:

- A. WGS packaged water chiller selection
- B. Compressor power input
- C. Corrected kW/ton
- D. Evaporator and condenser water pressure drop

Solution:

1. Chilled water range: $56^{\circ}\text{F} - 44^{\circ}\text{F} = 12^{\circ}\text{F}$ (nonstandard temperature difference).
2. From Table 8, a model WGS-170AW has close to the capacity to meet the job requirement and correction factors will adjust the capacity to the required value. For an evaporator leaving water temperature of 44°F and condenser water entering temperature of 85°F , with a 10-degree rise, the unit capacity rating table indicates:

Capacity: 169.6 Tons

Power: 121.3 kW

3. Correct for 12 degree Delta-T in the evaporator with factors from Table 5
Capacity: $169.6 \times 1.008 = 171.0$ Tons Power: $121.3 \times 1.002 = 121.5$ kW
4. Calculate new kW/ton: $(121.5 \text{ kW}) / (171.0 \text{ Tons}) = 0.710 \text{ kW/ton}$

5. From Figure 8, the evaporator pressure drop at 340 GPM is 9.2 feet

From Figure 9, the condenser pressure drop at 510 GPM is 7.5 feet (without manifold).

AA Remote Condenser

Selection Method

There are four ways to determine the capacity of a WGS chiller and McQuay condenser:

1. Calculate the performance using chiller and condenser capacities.
2. Plot the chiller heat rejection and condenser to find the balance point.
3. Use the matched chiller/condenser rating tables.
4. Contact the McQuay sales office for a computerized selection.

The performance of the WGS-AA chillers is listed by LWT (leaving chilled water temperature) and by saturated discharge temperature. Tons, Power, and THR (Total Heat Rejection) are given. This data can then be used to select a matching air-cooled or evaporative-cooled condenser. For McQuay ACH/ACL/ACX air-cooled condensers, use *Catalog A-C Cond.*

It is important to note that most condensers are rated on saturated *condensing* temperature (at the condenser) and that chillers are rated on saturated *discharge* temperature (at the compressor). Therefore, it is necessary to account for the discharge piping line loss. Most piping designs are based on a pressure drop of 5 psi (equivalent to about 2 degrees F. for R-134a). Unless otherwise stated, the condenser should be selected with a condensing temperature two degrees less than the compressor discharge temperature.

NOTE: McQuay WGS-AA units exceed the ASHRAE 90.1-2004 efficiency requirements of 10.58 full load EER based on standard rating conditions (full load at 44°F leaving chilled water temperature, 2.4 gpm/ton and 125°F saturated discharge temperature with 10 degrees of subcooling).

1. Ratings can be interpolated for any chiller water temperature between 40°F and 50°F (4.4°C and 10°C) but cannot be extrapolated (contact McQuay Sales Office for ratings outside this range).
2. Chilled water quantities. Ratings are based on a 10-degree F chilled water range and are applicable from a minimum of 6 degrees F to a maximum of 16 degrees F differential between entering and leaving chilled water temperatures.
3. Ratings are based on 0.0001 fouling factor for the evaporator. For other fouling factors, multiply ratings by cooler factors from Table 5. For applications using a glycol solution, see Table 2 or Table 3.

Selection Procedure

Normally the required chiller capacity in tons, the entering and leaving chilled water temperature, flow, and the design outdoor air temperature are known. Determine any unknown quantity using the formula:

$$\text{Tons} = \text{gpm} \times \text{Delta-T} / 24 \quad (\text{water only})$$

Capacity data is based on:

- Leaving chilled water temperatures from 40°F to 50°F (4.4°C to 10°C) with a 10 degree Delta-T. Selections can be interpolated between these leaving temperatures but not extrapolated. Correction factors for Delta-Ts other than 10 degrees are in Table 5. Exceeding the Delta-T range of 6 to 16 degrees will cause problems controlling unit unloading.
- Condensing temperatures (CT) from 120°F to 140°F (49°C to 61°C). Performance can be extrapolated from 105°F to 155°F (40°C to 68°C).
- Total Heat Rejection (THR) is used to select the condenser, whether it is a dry, air-cooled condenser or an evaporative condenser.

Several different size condensers can usually be matched to any given WGS-AA unit, depending on the condensing temperature that typically ranges from 20 to 30 degrees F above the design outdoor temperature. Increasing condensing temperatures will reduce the chiller capacity, increase its power consumption and result in a smaller condenser being required.

Larger size WGS units may require two condensers. The McQuay dual circuit/two row condensers have two refrigerant circuits that must be manifolded together in the field to match up with each of the two WGS circuits.

Normally, a WGS-AA chiller is selected to meet or exceed the required cooling capacity at some discharge temperature, and a condenser then selected with sufficient capacity to handle the heat rejection with the selected temperature difference (TD, difference between design outdoor dry bulb temperature and condensing temperature).

A more accurate solution can be achieved by plotting the capacity of the chiller and the condenser as a function of the TD and observing the curves intersection that is the system balance point. An example is shown in the following "Selection Example" section.

Sample Selection

Given: Required capacity of 160 tons cooling 384 gpm of water from 54°F to 44°F with 95°F design dry bulb temperature. Evaporator fouling factor of .0001.

Find:

1. WGS water chiller and a model ACX (lowest sound level) condenser selection
2. Compressor power input, chilled water pressure drop

Solution:

- 1) From Table 11, a Model WGS 190AA has the following performance at 125°F CT:
160.1 tons, 180.8 kW, 2538 MBH THR

- 2) A two-circuit condenser can be selected with the above information. For this example, a McQuay Model ACX (double circuit, two rows of fans, 830 rpm fan speed) condenser will be selected using selection procedures and data contained in *Catalog A-C Cond.*

An ambient temperature of 95°F and condensing temperature of 125°F results in a theoretical temperature difference of 30 degrees F. Subtracting a 2-degree pressure drop gives an actual temperature difference of 28 degrees. $\text{THR}/\text{TD}=2538/28=90.6$

A Model ACX 200A-D with 14 fpi will do the service with a heat rejection factor of 96.1 times 0.95 (R-134a correction factor) equaling 91.3, which exceeds the heat rejection requirement. The additional capacity will lower the chiller condensing temperature slightly, increase capacity and improve efficiency.

Graphical solutions can also be used as shown in the following typical example:

- a) Take the WGS heat rejection values at two temperature differences and connect, them, drawing a heat rejection curve.
- b) Plot and connect the air-cooled condenser capacity (from *Catalog A-C Cond*) at two different temperature differences. Take the catalog heat rejection value for the selected unit and fin spacing and multiply it by 25 and 30 degrees TD times 0.95 correction for R-134a.

To account for line loss, enter the condenser heat rejection capacity from the catalog at two degrees higher than the catalog value. For example,

use the cataloged condenser capacity at 30 degrees, but enter the value on the plot at 32 degrees.

- c) The intersection of the curves is the full load balance point for the chiller/condenser combination.

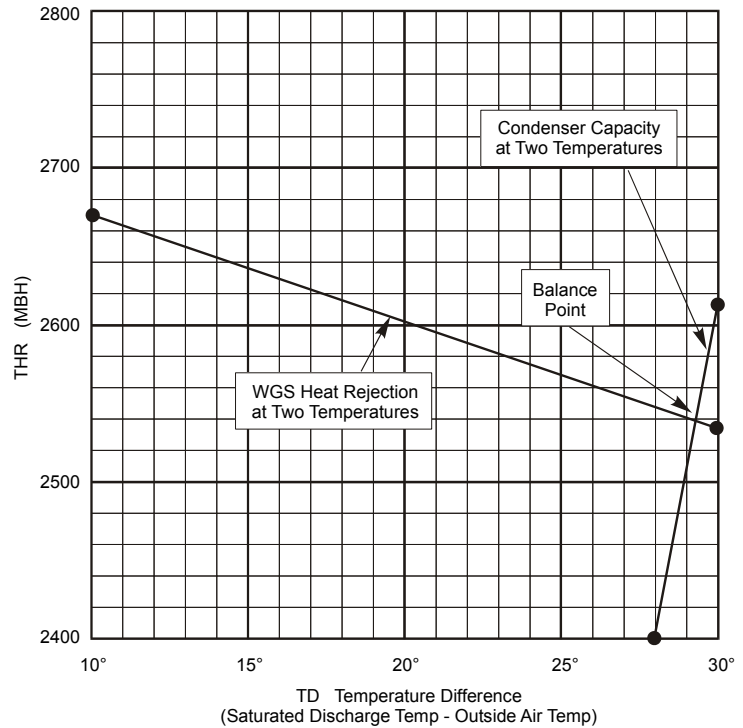

WGS-AA with Matching A-C Condensers

Table 13 and Table 14 give performance data for WGS-AA chillers matched with McQuay condenser models ACH and ACX respectively. The number of rating points is condensed due to the large number of chiller/condenser combinations. If particular job conditions do not match the table rating points, do not extrapolate. Performance can be interpolated between 42°F and 44°F chilled water and 95°F and 105°F ambient temperatures.

Other selections can be made using WGS-AA performance data in Table 11 on page 22 and air-cooled condenser selection data in *Catalog A-C Cond*. The local McQuay sales office can obtain matched computerized selections

A separate single-circuit condenser for each WGS circuit is used for some selections on the larger WGS units. When two dual-circuit condensers (with two refrigerant circuits on each condenser) are used, the two circuits on each condenser must be manifolded together in the field.

The performance shown is based on two-degree F (5 psi) discharge line pressure drop and 42°F and 44°F LWT, fouling factor of 0.0001, 10-degree delta-T, and sea level altitude. See Table 7 for altitude correction factors.

In many cases, selecting very large condensers will result in reaching a point of diminishing return on efficiency, and EERs can actually decrease due to increased fan power exceeding chiller power savings.

The power (PWR) and efficiency (EER) shown include the compressor power, condenser fan power and control power.

Performance Adjustment Factors

Ethylene and Propylene Glycol Factors

WGS units are designed to operate with a leaving chilled fluid temperature from 20°F to 60°F (-6.7°C to 16°C). Leaving chilled fluid temperatures below 40°F (4.6°C) result in suction temperatures at or below the freezing point of water and a glycol solution is required. The use of glycol in the evaporator will reduce the performance of the unit, depending on the glycol concentration. This should be taken into consideration during initial system design.

McQuay encourages a minimum concentration of 25% be provided on all glycol applications. Glycol concentrations below 25% are too diluted for long-term corrosion protection of ferrous metals so corrosion inhibitors need to be recalculated and possibly added to the system. Glycol in the condenser will have a negligible effect on performance because glycol at higher temperatures will perform with characteristics similar to water.

Table 2, Adjustment Factors for Ethylene Glycol

% E.G	Freeze Point		Capacity	Power	Flow	PD
	°F	°C				
10	26	-3.3	0.996	0.999	1.035	1.096
20	18	-7.8	0.986	0.998	1.060	1.219
30	7	-13.9	0.978	0.996	1.092	1.352
40	-7	-21.7	0.966	0.993	1.131	1.530
50	-28	-33.3	0.955	0.991	1.182	1.751

Table 3, Adjustment Factors for Propylene Glycol

% P.G	Freeze Point		Capacity	Power	Flow	PD
	°F	°C				
10	26	-3.3	0.991	0.999	1.016	1.092
20	19	-7.2	0.979	0.996	1.032	1.195
30	9	-12.8	0.964	0.993	1.057	1.347
40	-5	-20.6	0.944	0.988	1.092	1.546
50	-27	-32.8	0.927	0.985	1.139	1.854

NOTE: Glycol applications are not included in the ARI certification program.

Table 4, Freeze Protection

Temperature °F (°C)	Percent Volume Glycol Concentration Required			
	For Freeze Protection		For Burst Protection	
	Ethylene Glycol	Propylene Glycol	Ethylene Glycol	Propylene Glycol
20 (6.7)	16	18	11	12
10 (-12.2)	25	29	17	20
0 (-17.8)	33	36	22	24
-10 (-23.3)	39	42	26	28
-20 (-28.9)	44	46	30	30
-30 (-34.4)	48	50	30	33
-40 (-40.0)	52	54	30	35
-50 (-45.6)	56	57	30	35
-60 (-51.1)	60	60	30	35

Notes:

1. These figures are examples only and cannot be appropriate to every situation. Generally, for an extended margin of protection, select a temperature at least 10°F lower than the expected lowest fluid leaving temperature. Inhibitor levels should be adjusted for solutions less than 25% glycol.

Evaporator and Condenser Delta-T Factors

Performance tables are based on a 10°F (5.5°C) temperature difference through the evaporator and condenser. A temperature difference other than 10°F (5.5°C) will result in unit performance being different from what is shown. Adjustment factors for applications having temperature drops between 6°F and 16°F (3.3°C to 8.9°C) can be found in Table 5 and Table 6.

Fouling Factor

Performance tables are based on water with a fouling factor of 0.0001 ft² x hr x °F/BTU (0.0176 m² x °C/kW) in the evaporator and 0.00025 ft² x hr x °F/BTU (0.044 m² x °C/kW) in water-cooled condensers according to ARI 550/590-98. Increased fouling decreases performance. See Table 5 and Table 6 for performance with other fouling factors.

Table 5, Evaporator Adjustment Factors

Chilled Water Delta T		Fouling Factor							
		0.0001 (0.0176)		0.00025 (0.044)		0.00075 (0.132)		0.00175 (0.308)	
°F	°C	Cap.	Power	Cap.	Power	Cap.	Power	Cap.	Power
6	3.3	0.981	0.996	0.970	0.994	0.938	0.988	0.880	0.975
8	4.4	0.991	0.999	0.981	0.996	0.948	0.990	0.889	0.977
10	5.6	1.000	1.000	0.990	0.998	0.957	0.991	0.898	0.978
12	6.7	1.008	1.002	0.997	1.000	0.964	0.993	0.904	0.980
14	7.8	1.015	1.004	1.004	1.001	0.971	0.995	0.911	0.982
16	8.9	1.021	1.005	1.011	1.003	0.977	0.996	0.917	0.983

Table 6, Condenser Adjustment factors

Condenser Water Delta T		Fouling Factor							
		0.0001 (0.0176)		0.00025 (0.044)		0.00075 (0.132)		0.00175 (0.308)	
°F	°C	Cap.	Power	Cap.	Power	Cap.	Power	Cap.	Power
6	3.3	1.008	0.956	1.006	0.962	1.002	0.987	0.993	1.042
8	4.4	1.004	0.974	1.003	0.980	0.999	1.005	0.990	1.062
10	5.6	1.001	0.993	1.000	1.000	0.996	1.026	0.986	1.083
12	6.7	0.998	1.014	0.997	1.020	0.992	1.046	0.983	1.105
14	7.8	0.994	1.035	0.993	1.042	0.989	1.068	0.980	1.128
16	8.9	0.990	1.057	0.989	1.064	0.985	1.091	0.976	1.153

Table 7, Altitude Correction Factors for Chillers with Air-Cooled Condensers

	1000 ft.	2000 ft.	3000 ft.	4000 ft.	5000 ft.	6000 ft.
Capacity	0.997	0.994	0.991	0.988	0.985	0.981
Power	1.005	1.011	1.016	1.022	1.028	1.035

Water Treatment

For optimum unit operation, proper water treatment must be maintained. Scaling and dirt in a system will vary significantly depending on local water conditions. Water treatment should be based on characteristics of the area's water. Improper or untreated water can lead to scale buildup, erosion and corrosion in both the condenser and evaporator. McQuay will not accept responsibility for performance degradation or equipment failures due to poorly or improperly treated water.

Performance Data

WGS-AW Water-Cooled

Table 8, WGS 130AW - WGS 190AW, IP Units

WGS Unit Size	LWT (deg F)	Entering Condenser Water Temperature (deg F)														
		75			80			85			90			95		
		Unit Tons	PWR kW	Unit kW/Ton	Unit Tons	PWR kW	Unit kW/Ton	Unit Tons	PWR kW	Unit kW/Ton	Unit Tons	PWR kW	Unit kW/Ton	Unit Tons	PWR kW	Unit kW/Ton
130	40	126.7	81.5	0.643	123.2	87.6	0.711	119.6	93.9	0.785	116.0	100.5	0.866	112.4	107.3	0.955
	42	132.0	81.6	0.618	128.4	87.7	0.683	124.8	94.1	0.754	121.1	100.7	0.832	117.3	107.6	0.917
	44	137.5	81.6	0.594	133.8	87.8	0.656	130.0	94.3	0.725	126.2	101.0	0.800	122.4	107.9	0.882
	46	143.2	81.7	0.571	139.4	87.9	0.631	135.5	94.4	0.697	131.6	101.2	0.769	127.6	108.2	0.848
	48	149.0	81.8	0.549	145.1	88.0	0.607	141.1	94.6	0.670	137.1	101.4	0.740	133.0	108.4	0.816
	50	155.0	81.8	0.528	151.0	88.1	0.584	146.9	94.7	0.645	142.7	101.6	0.712	138.5	108.7	0.785
140	40	137.1	88.5	0.646	133.3	95.0	0.713	129.5	101.7	0.786	125.6	108.7	0.865	121.6	115.9	0.953
	42	142.8	88.7	0.621	139.0	95.2	0.685	135.0	102.0	0.756	131.0	109.0	0.832	126.9	116.3	0.916
	44	148.8	88.9	0.598	144.8	95.5	0.659	140.7	102.3	0.727	136.6	109.4	0.801	132.4	116.8	0.882
	46	154.9	89.1	0.575	150.7	95.7	0.635	146.6	102.6	0.700	142.3	109.7	0.771	138.0	117.1	0.849
	48	161.1	89.3	0.554	156.9	95.9	0.611	152.6	102.8	0.674	148.2	110.0	0.742	143.8	117.5	0.817
	50	167.5	89.5	0.534	163.2	96.1	0.589	158.7	103.1	0.649	154.2	110.3	0.715	149.7	117.9	0.788
160	40	152.8	97.0	0.635	148.5	103.9	0.700	144.3	111.2	0.771	139.9	118.7	0.848	135.5	126.5	0.933
	42	159.2	97.3	0.611	154.8	104.3	0.674	150.4	111.6	0.742	145.9	119.1	0.817	141.4	127.0	0.898
	44	165.8	97.6	0.589	161.3	104.7	0.649	156.7	112.0	0.715	152.1	119.6	0.786	147.4	127.5	0.865
	46	172.5	98.0	0.568	167.9	105.0	0.625	163.2	112.4	0.689	158.5	120.1	0.758	153.6	128.1	0.833
	48	179.5	98.3	0.548	174.7	105.4	0.603	169.9	112.8	0.664	165.0	120.5	0.730	160.0	128.6	0.803
	50	186.6	98.6	0.528	181.7	105.7	0.582	176.7	113.1	0.640	171.7	120.9	0.704	166.6	129.1	0.775
170	40	165.2	105.2	0.637	160.7	112.6	0.701	156.1	120.2	0.771	151.4	128.2	0.847	146.6	136.6	0.932
	42	172.2	105.7	0.614	167.5	113.0	0.675	162.7	120.8	0.742	157.9	128.8	0.816	153.0	137.2	0.897
	44	179.3	106.1	0.592	174.5	113.5	0.651	169.6	121.3	0.715	164.6	129.4	0.786	159.6	137.9	0.864
	46	186.7	106.6	0.571	181.7	114.0	0.627	176.6	121.8	0.690	171.5	130.0	0.758	166.3	138.5	0.833
	48	194.2	107.0	0.551	189.1	114.5	0.606	183.9	122.3	0.665	178.6	130.5	0.731	173.2	139.1	0.803
	50	201.9	107.5	0.532	196.6	115.0	0.585	191.3	122.8	0.642	185.9	131.1	0.705	180.4	139.7	0.775
190	40	177.5	113.4	0.639	172.6	121.1	0.701	167.6	129.1	0.770	162.6	137.6	0.846	157.5	146.4	0.929
	42	184.9	114.0	0.616	179.9	121.7	0.677	174.8	129.8	0.743	169.6	138.3	0.816	164.3	147.2	0.896
	44	192.5	114.6	0.595	187.3	122.3	0.653	182.1	130.5	0.717	176.7	139.0	0.787	171.3	148.0	0.864
	46	200.3	115.2	0.575	195.0	123.0	0.631	189.6	131.2	0.692	184.1	139.8	0.759	178.5	148.8	0.833
	48	208.3	115.9	0.556	202.9	123.7	0.610	197.3	131.9	0.668	191.7	140.5	0.733	185.9	149.6	0.804
	50	216.6	116.5	0.538	210.9	124.3	0.589	205.2	132.6	0.646	199.4	141.3	0.708	193.5	150.4	0.777

Notes:

1. Ratings in accordance with ARI Standard 550/590-98. Shaded and bold ratings are at ARI standard conditions.
2. Ratings based on R-134a, evaporator fouling factor of 0.0001, evaporator water flow of 2.4 gpm/ton, 10 degree F. Delta-T, and condenser fouling factor of 0.00025, and condenser water flow of 3.0 gpm/ton.
3. Interpolation is allowed; extrapolation is not permitted. Consult the McQuay representative for performance outside the ratings shown.
4. October 2001 ASHRAE 90.1 minimum requirements are at ARI standard rating conditions of 44°F chilled water temperature, 2.4 gpm/ton and 85°F condenser water temperature, 3 gpm/ton. Requirements are:
 ≥150 Tons, 16.7 EER, 19.1 IPLV
 <150 Tons, 15.2 EER, 17.7 IPLV
5. COP = 3.516/(kW/Ton) EER = 12/(kW/Ton)
6. The ratings in this catalog are consistent with the McQuayTools™ selection program version shown inside front cover. For the most up-to-date information, please go to www.mcquay.com.

Table 9, WGS 130AW - WGS 190AW, SI Units

WGS Unit Size	LWT (deg C)	Entering Condenser Water Temperature (deg C)														
		24			27			30			32			35		
		Unit	PWR	Unit	Unit	PWR	Unit	Unit	PWR	Unit	Unit	PWR	Unit	Unit	PWR	Unit
		KW	kWi	COP	KW	kWi	COP	KW	kWi	COP	KW	kWi	COP	KW	kWi	COP
130	5.0	454.3	81.8	5.56	440.8	88.4	4.99	427.1	95.3	4.48	417.9	100.1	4.17	403.9	107.4	3.76
	6.0	471.5	81.8	5.76	457.6	88.5	5.17	443.5	95.5	4.64	434.1	100.3	4.33	419.7	107.7	3.90
	7.0	489.1	81.9	5.97	474.9	88.6	5.36	460.4	95.7	4.81	450.7	100.5	4.48	435.9	108.0	4.04
	8.0	507.2	82.0	6.19	492.5	88.7	5.55	477.7	95.8	4.99	467.7	100.7	4.65	452.5	108.2	4.18
	9.0	525.7	82.0	6.41	510.6	88.8	5.75	495.4	96.0	5.16	485.1	100.9	4.81	469.6	108.5	4.33
	10.0	544.6	82.1	6.63	529.2	88.9	5.95	513.5	96.1	5.35	503.0	101.0	4.98	487.0	108.7	4.48
140	5.0	491.7	88.9	5.53	477.1	95.9	4.97	462.3	103.3	4.48	452.3	108.3	4.18	437.1	116.1	3.76
	6.0	510.1	89.1	5.73	495.2	96.1	5.15	479.9	103.5	4.64	469.7	108.6	4.32	454.1	116.5	3.90
	7.0	529.1	89.2	5.93	513.7	96.4	5.33	498.1	103.8	4.80	487.5	108.9	4.48	471.5	116.9	4.03
	8.0	548.5	89.4	6.13	532.7	96.6	5.52	516.6	104.1	4.97	505.8	109.2	4.63	489.4	117.2	4.18
	9.0	568.3	89.6	6.34	552.1	96.8	5.71	535.6	104.3	5.14	524.5	109.5	4.79	507.7	117.6	4.32
	10.0	588.6	89.7	6.56	572.0	97.0	5.90	555.1	104.5	5.31	543.7	109.8	4.95	526.4	117.9	4.47
160	5.0	548.0	97.5	5.62	531.6	105.0	5.06	515.0	112.9	4.56	503.8	118.3	4.26	486.8	126.7	3.84
	6.0	568.5	97.7	5.82	551.7	105.3	5.24	534.6	113.3	4.72	523.1	118.7	4.41	505.7	127.2	3.97
	7.0	589.5	98.0	6.01	572.2	105.6	5.42	554.7	113.6	4.88	542.9	119.1	4.56	525.0	127.7	4.11
	8.0	611.0	98.3	6.21	593.3	106.0	5.60	575.3	114.0	5.05	563.2	119.5	4.71	544.8	128.2	4.25
	9.0	633.0	98.6	6.42	614.8	106.3	5.79	596.4	114.4	5.22	584.0	119.9	4.87	565.1	128.6	4.39
	10.0	655.5	98.9	6.63	636.9	106.6	5.97	618.0	114.7	5.39	605.2	120.3	5.03	585.9	129.1	4.54
170	5.0	592.7	105.8	5.60	575.1	113.7	5.06	557.2	122.1	4.56	545.1	127.9	4.26	526.8	136.9	3.85
	6.0	614.9	106.1	5.79	596.8	114.2	5.23	578.4	122.6	4.72	566.1	128.4	4.41	547.3	137.5	3.98
	7.0	637.7	106.5	5.98	619.1	114.6	5.40	600.2	123.1	4.88	587.5	128.9	4.56	568.2	138.1	4.12
	8.0	661.0	107.0	6.18	642.0	115.0	5.58	622.6	123.5	5.04	609.6	129.4	4.71	589.8	138.6	4.25
	9.0	684.9	107.4	6.38	665.3	115.5	5.76	645.5	124.0	5.20	632.1	129.9	4.86	611.8	139.2	4.40
	10.0	709.3	107.8	6.58	689.3	115.9	5.95	668.9	124.5	5.37	655.2	130.4	5.02	634.3	139.7	4.54
190	5.0	636.6	114.0	5.58	617.7	122.4	5.05	598.5	131.2	4.56	585.6	137.3	4.27	565.9	146.8	3.86
	6.0	660.2	114.5	5.76	640.9	122.9	5.21	621.2	131.8	4.71	607.9	137.9	4.41	587.8	147.5	3.98
	7.0	684.5	115.1	5.95	664.7	123.5	5.38	644.5	132.4	4.87	630.8	138.6	4.55	610.1	148.2	4.12
	8.0	709.4	115.7	6.13	689.0	124.1	5.55	668.3	133.0	5.02	654.3	139.2	4.70	633.1	148.9	4.25
	9.0	734.8	116.2	6.32	713.9	124.7	5.72	692.7	133.7	5.18	678.3	139.9	4.85	656.5	149.6	4.39
	10.0	760.9	116.8	6.51	739.4	125.3	5.90	717.6	134.3	5.34	702.9	140.6	5.00	680.5	150.4	4.53

Notes:

1. Ratings based on R-134a, evaporator fouling factor of 0.0176 and condenser fouling factor of 0.044, evaporator water flow of 0.043 L/s-kW and condenser water flow of 0.054 L/s-kW.
2. Interpolation is allowed; extrapolation is not permitted. Consult McQuay for performance outside the ratings shown.
3. The ratings in this catalog are consistent with the McQuayTools™ selection program version shown inside front cover. For the most up-to-date information, please go to www.mcquay.com.

WGS-AW Part Load Data

Table 10, Part Load Performance

WGS UNIT SIZE	% LOAD	60 HZ			
		CAPACITY TONS	POWER kW _i	KW/TON	IPLV
130	100.0	130.0	94.3	0.725	0.554
	75.0	97.6	58.0	0.595	
	50.0	65.0	33.6	0.517	
	25.0	32.5	18.1	0.557	
140	100.0	140.7	102.3	0.727	0.545
	75.0	105.5	62.4	0.592	
	50.0	70.3	35.5	0.505	
	25.0	35.2	19.1	0.543	
160	100.0	156.7	112.0	0.715	0.546
	75.0	117.5	68.7	0.585	
	50.0	78.4	40.2	0.513	
	25.0	39.2	21.1	0.538	
170	100.0	169.6	121.3	0.715	0.536
	75.0	127.2	73.8	0.580	
	50.0	84.8	42.4	0.500	
	25.0	42.4	22.3	0.526	
190	100.0	182.1	130.5	0.717	0.548
	75.0	136.5	79.9	0.585	
	50.0	91.0	47.3	0.520	
	25.0	45.5	24.0	0.528	

Note: IPLV values calculated in accordance with the ASHRAE Standard 550/590 current at the time of printing. The ratings in this catalog are consistent with the McQuayTools™ selection program version shown inside front cover. For the most up-to-date information, please go to www.mcquay.com.

WGS-AA Remote Condenser

Table 11, WGS 130AA – WGS 190AA, IP Units

WGS Unit Size	LWT (deg F)	Condensing Temperature (deg F)														
		120			125			130			135			140		
		Unit Tons	PWR kW	Unit THR	Unit Tons	PWR kW	Unit THR	Unit Tons	PWR kW	Unit THR	Unit Tons	PWR kW	Unit THR	Unit Tons	PWR kW	Unit THR
130	40	109.8	123.1	1738	106.0	130.4	1717	102.2	137.6	1696	98.4	144.9	1675	94.6	152.2	1655
	42	114.8	123.6	1800	110.9	130.9	1778	107.0	138.2	1756	103.1	145.6	1734	99.2	152.9	1712
	44	120.0	124.1	1864	116.0	131.4	1840	111.9	138.8	1817	107.9	146.2	1794	103.8	153.6	1770
	46	125.4	124.5	1929	121.2	132.0	1905	117.0	139.4	1880	112.9	146.9	1856	108.7	154.4	1831
	48	130.9	124.9	1997	126.6	132.4	1971	122.3	140.0	1945	118.0	147.6	1919	113.7	155.1	1894
	50	136.6	125.3	2067	132.2	132.9	2039	127.7	140.5	2012	123.3	148.2	1985	118.9	155.8	1958
140	40	119.2	133.3	1886	115.1	141.2	1863	111.0	149.1	1841	106.9	157.0	1818	102.8	164.9	1796
	42	124.7	133.9	1953	120.4	141.8	1929	116.2	149.8	1905	111.9	157.7	1881	107.7	165.6	1857
	44	130.3	134.4	2022	125.9	142.4	1997	121.5	150.4	1972	117.1	158.4	1946	112.8	166.4	1921
	46	136.1	134.9	2094	131.6	143.0	2067	127.1	151.1	2040	122.5	159.2	2014	118.0	167.3	1987
	48	142.1	135.4	2167	137.4	143.6	2139	132.8	151.7	2111	128.1	159.9	2083	123.4	168.1	2055
	50	148.2	135.9	2243	143.4	144.1	2213	138.6	152.4	2184	133.8	160.6	2154	129.0	168.8	2124
160	40	128.9	144.0	2038	124.4	152.5	2013	120.0	161.0	1989	115.5	169.5	1965	111.1	178.1	1940
	42	134.7	144.6	2110	130.1	153.2	2084	125.6	161.8	2059	121.0	170.3	2033	116.4	178.9	2007
	44	140.8	145.2	2185	136.1	153.9	2158	131.3	162.5	2130	126.6	171.1	2103	121.9	179.8	2076
	46	147.0	145.8	2262	142.2	154.5	2233	137.3	163.2	2205	132.4	171.9	2176	127.5	180.6	2147
	48	153.5	146.4	2342	148.5	155.2	2311	143.4	164.0	2281	138.4	172.7	2250	133.4	181.5	2220
	50	160.1	147.0	2423	155.0	155.8	2391	149.8	164.7	2359	144.6	173.5	2327	139.4	182.4	2295
170	40	140.2	156.7	2217	135.4	166.0	2191	130.6	175.3	2165	125.7	184.6	2139	120.9	193.9	2112
	42	146.6	157.4	2296	141.6	166.8	2268	136.6	176.1	2241	131.6	185.5	2213	126.7	194.8	2185
	44	153.2	158.2	2378	148.0	167.6	2348	142.9	177.0	2319	137.8	186.4	2289	132.6	195.8	2259
	46	160.0	158.9	2462	154.7	168.4	2430	149.4	177.8	2399	144.1	187.3	2368	138.8	196.7	2337
	48	166.9	159.6	2548	161.5	169.1	2515	156.0	178.6	2482	150.6	188.2	2449	145.1	197.7	2416
	50	174.2	160.3	2637	168.5	169.9	2602	162.9	179.5	2567	157.3	189.1	2533	151.7	198.7	2498
190	40	151.7	169.0	2397	146.4	179.0	2368	141.2	189.1	2340	136.0	199.1	2312	130.8	209.2	2283
	42	158.5	169.8	2482	153.2	179.9	2452	147.8	190.0	2422	142.4	200.1	2392	137.0	210.2	2362
	44	165.6	170.7	2570	160.1	180.8	2538	154.6	190.9	2506	149.0	201.0	2474	143.5	211.2	2442
	46	173.0	171.5	2661	167.3	181.7	2627	161.5	191.9	2593	155.8	202.0	2559	150.1	212.2	2526
	48	180.5	172.3	2754	174.6	182.6	2718	168.7	192.8	2683	162.8	203.0	2647	157.0	213.3	2611
	50	188.3	173.2	2850	182.2	183.5	2813	176.1	193.8	2775	170.1	204.1	2737	164.0	214.4	2700

Notes:

1. Ratings based on R-134a, evaporator fouling of 0.0001, evaporator flow of 2.4 gpm/ton.
2. Interpolation is allowed; extrapolation from 105°F to 120°F only, is permitted. Consult the McQuay representative for performance outside the cataloged ratings.
3. EER = (Cooling Tons x 12000) / (kW Input x 1000). This does not include condenser power input.
4. KW/Ton = 12/EER, COP = 3.516 / (kW/Ton)
5. October 2001 ASHRAE 90.1 minimum requirements for air-cooled chillers without condensers are 10.58 EER at full load and 11.8 IPLV at standard conditions (44°F, 2.4 gpm/ton, 125° saturated discharge temperature, 10 degrees subcooling). All McQuay WGS-AA chillers meet or exceed the efficiency requirements.
6. The ratings in this catalog are consistent with the McQuayTools™ selection program version shown inside front cover. For the most up-to-date information, please go to www.mcquay.com.

Table 12, WGS 130AA – WGS 190AA, S.I. Units

WGS Unit Size	LWT (deg C)	Condensing Temperature (deg C)														
		49			52			55			58			61		
		Unit	PWR	THR	Unit	PWR	THR	Unit	PWR	THR	Unit	PWR	THR	Unit	PWR	THR
		KW	kWi	KW	KW	kWi	KW	KW	kWi	KW	KW	kWi	KW	KW	kWi	KW
130	5.0	394.5	123.6	518.1	379.8	131.5	511.3	365.1	139.4	504.5	350.5	147.3	497.8	335.8	155.2	491.0
	6.0	410.6	124.1	534.6	395.5	132.0	527.5	380.4	140.0	520.4	365.3	147.9	513.3	350.3	155.9	506.1
	7.0	427.2	124.5	551.6	411.7	132.5	544.2	396.1	140.5	536.7	380.6	148.5	529.2	365.1	156.6	521.7
	8.0	444.2	124.9	569.1	428.3	133.0	561.2	412.3	141.1	553.4	396.4	149.1	545.5	380.4	157.2	537.7
	9.0	461.7	125.2	587.0	445.3	133.4	578.7	429.0	141.6	570.5	412.6	149.7	562.3	396.2	157.9	554.1
	10.0	479.7	125.6	605.3	462.9	133.8	596.7	446.1	142.1	588.1	429.2	150.3	579.5	412.4	158.6	571.0
140	5.0	428.3	133.9	562.2	412.4	142.5	554.9	396.5	151.0	547.5	380.6	159.6	540.2	364.7	168.1	532.9
	6.0	445.8	134.4	580.2	429.4	143.0	572.4	413.1	151.6	564.7	396.7	160.3	557.0	380.4	168.9	549.2
	7.0	463.7	134.9	598.6	446.9	143.6	590.5	430.1	152.3	582.4	413.3	160.9	574.2	396.5	169.6	566.1
	8.0	482.2	135.4	617.6	464.9	144.1	609.0	447.7	152.9	600.5	430.4	161.6	592.0	413.1	170.4	583.5
	9.0	501.2	135.8	637.0	483.4	144.6	628.0	465.7	153.5	619.1	447.9	162.3	610.2	430.1	171.1	601.2
	10.0	520.7	136.2	656.9	502.4	145.1	647.5	484.2	154.0	638.2	465.9	162.9	628.9	447.7	171.8	619.5
160	5.0	462.9	144.6	607.5	445.7	153.9	599.6	428.5	163.1	591.6	411.4	172.3	583.7	394.2	181.6	575.8
	6.0	481.7	145.2	626.9	464.0	154.5	618.5	446.4	163.8	610.2	428.8	173.1	601.8	411.1	182.4	593.5
	7.0	501.1	145.7	646.8	482.9	155.1	638.0	464.8	164.5	629.3	446.7	173.8	620.5	428.5	183.2	611.7
	8.0	521.0	146.3	667.3	502.4	155.7	658.1	483.7	165.1	648.8	465.1	174.6	639.6	446.4	184.0	630.4
	9.0	541.4	146.8	688.2	522.3	156.3	678.6	503.1	165.8	668.9	484.0	175.3	659.3	464.8	184.8	649.6
	10.0	562.5	147.3	709.8	542.8	156.9	699.7	523.1	166.5	689.6	503.4	176.0	679.4	483.7	185.6	669.3
170	5.0	503.6	157.4	661.1	485.0	167.5	652.5	466.4	177.6	644.0	447.7	187.7	635.4	429.1	197.8	626.9
	6.0	524.1	158.1	682.2	504.9	168.2	673.1	485.8	178.4	664.1	466.6	188.5	655.1	447.5	198.6	646.1
	7.0	545.1	158.8	703.9	525.4	168.9	694.3	505.7	179.1	684.8	486.0	189.3	675.3	466.3	199.5	665.8
	8.0	566.7	159.4	726.1	546.5	169.6	716.1	526.3	179.9	706.1	506.0	190.1	696.1	485.8	200.4	686.2
	9.0	588.9	160.0	748.9	568.1	170.3	738.5	547.3	180.7	728.0	526.5	191.0	717.5	505.7	201.3	707.0
	10.0	611.7	160.7	772.4	590.3	171.0	761.4	569.0	181.4	750.4	547.6	191.8	739.4	526.3	202.2	728.4
190	5.0	544.7	169.8	714.5	524.6	180.7	705.3	504.5	191.6	696.1	484.4	202.5	686.8	464.2	213.3	677.6
	6.0	566.8	170.6	737.3	546.1	181.5	727.6	525.4	192.4	717.8	504.7	203.3	708.1	484.1	214.2	698.3
	7.0	589.5	171.3	760.8	568.2	182.3	750.5	547.0	193.3	740.2	525.7	204.2	729.9	504.5	215.2	719.6
	8.0	612.8	172.1	784.9	591.0	183.1	774.0	569.1	194.1	763.2	547.3	205.1	752.4	525.4	216.1	741.6
	9.0	636.7	172.8	809.5	614.3	183.9	798.2	591.8	195.0	786.8	569.4	206.0	775.5	547.0	217.1	764.1
	10.0	661.3	173.6	834.8	638.2	184.7	822.9	615.2	195.8	811.0	592.2	207.0	799.1	569.1	218.1	787.2

Notes:

1. Ratings based on R-134a, evaporator fouling of 0.0176, evaporator flow of 0.043 L/s-kW.
2. Remote condenser units are not included in the ARI Certification Program.
3. Interpolation is allowed; extrapolation from 49°C to 41°C only, is permitted. Consult McQuay for performance outside the cataloged ratings.
4. COP = Cooling kW / Input kW
5. COP = 3.516/(kW/Ton) EER = 12/(kW/Ton)
6. The ratings in this catalog are consistent with the McQuayTools™ selection program version shown inside front cover. For the most up-to-date information, please go to www.mcquay.com.

WGS-AA with Matching Condenser

Table 13, WGS-AA Chillers Matched with McQuay ACH (1140 RPM) Air-Cooled Condensers

WGS Model	With Cond	LWT (°F)	Ambient Air Temperature (°F)						With Cond	LWT (°F)	Ambient Air Temperature (°F)						
			95			105					95			105			
			Tons	PWR	EER	Tons	PWR	EER			Tons	PWR	EER	Tons	PWR	EER	
130AA	ACH 100D	42	111.1	142.0	9.4	103.8	155.7	8.0	ACH 160D	42	118.4	136.0	10.4	112.2	142.7	9.1	
		44	115.4	144.0	9.6	108.0	157.5	8.2		44	123.3	137.3	10.8	116.8	149.1	9.4	
	ACH 110D	42	112.9	142.5	9.5	105.6	156.2	8.1	ACH 200D	42	120.7	135.6	10.7	114.5	147.3	9.3	
		44	117.4	144.3	9.8	109.9	158.0	8.3		44	125.7	136.8	11.0	119.3	148.5	9.6	
	ACH 130D	42	115.6	137.5	10.1	108.6	150.7	8.6	ACH 225D	42	122.3	136.6	10.7	115.7	148.9	9.3	
		44	120.4	138.8	10.4	113.0	152.3	8.9		44	127.4	137.6	11.1	120.7	149.8	9.7	
	ACH 140D	42	116.5	139.7	10.0	109.8	152.2	8.7	(2) ACH 110S	42	122.3	123.2	11.9	115.7	135.5	10.2	
		44	121.3	140.9	10.3	114.3	153.7	8.9		44	127.4	124.2	12.3	120.7	136.4	10.6	
	140AA	ACH 100D	42	118.6	156.6	9.1	110.6	171.3	7.7	ACH 160D	42	127.4	147.0	10.4	120.5	160.7	9.0
			44	123.1	159.0	9.3	115.6	171.3	7.9		44	132.7	148.4	10.7	125.5	162.4	9.3
ACH 110D		42	120.8	156.6	9.3	112.7	171.3	7.9	ACH 200D	42	130.1	146.1	10.7	123.3	159.6	9.3	
		44	125.4	158.7	9.5	117.2	173.6	8.1		44	135.3	147.4	11.0	128.3	161.0	9.6	
ACH 130D		42	124.4	149.9	10.0	116.2	164.9	8.5	ACH 225D	42	131.9	146.5	10.8	125.0	161.1	9.4	
		44	129.2	151.8	10.2	120.9	166.9	8.7		44	137.3	147.7	11.2	130.3	161.2	9.7	
ACH 140D		42	125.5	151.4	10.0	117.7	166.0	8.5	(2) ACH 110S	42	131.9	133.1	11.9	125.0	146.7	10.2	
		44	130.6	152.9	10.3	122.4	167.9	8.8		44	137.3	134.3	12.3	130.3	147.8	10.6	
160AA		ACH 110D	42	128.5	171.6	9.0	120.0	187.6	7.7	ACH 200D	42	140.7	159.1	10.6	132.0	172.8	9.2
			44	133.5	174.1	9.2	124.8	190.2	7.9		44	146.4	160.7	10.9	137.4	174.5	9.4
	ACH 130D	42	132.5	164.1	9.7	123.9	180.2	8.3	ACH 225D	42	142.9	154.0	10.8	134.1	172.6	9.3	
		44	137.7	166.3	9.9	129.0	182.5	8.5		44	148.6	160.4	11.1	139.7	174.1	9.6	
	ACH 140D	42	134.2	164.7	9.8	125.6	180.9	8.3	(2) ACH 110S	42	142.9	145.6	11.3	134.1	159.3	10.1	
		44	139.5	166.8	10.0	130.7	183.1	8.6		44	148.6	148.0	12.1	139.7	160.7	10.4	
	ACH 160D	42	137.5	160.0	10.3	128.8	174.8	8.8	(2) ACH 130D	42	144.5	144.5	12.0	135.8	158.6	10.3	
		44	143.0	161.5	10.6	134.1	176.7	9.1		44	150.4	145.8	12.4	141.5	159.7	10.6	
	170AA	ACH 130D	42	142.0	181.4	9.4	132.6	199.0	8.0	ACH 225D	42	152.6	172.0	10.6	144.7	187.9	9.2
			44	147.4	184.1	9.6	137.7	201.6	8.2		44	158.8	173.7	11.0	150.6	188.8	9.5
ACH 140D		42	144.0	181.5	9.5	134.6	199.2	8.1	(2) ACH 110S	42	152.6	158.6	11.5	150.6	176.4	10.0	
		44	149.5	184.0	9.8	139.8	201.6	8.3		44	158.8	160.3	11.9	150.6	176.4	10.2	
ACH 160D		42	147.5	174.6	10.1	138.5	191.9	8.7	(2) ACH 130D	42	154.6	157.0	10.8	146.6	172.7	10.2	
		44	153.6	176.6	10.4	143.9	194.2	8.9		44	160.8	158.6	12.2	152.7	174.4	10.5	
ACH 200D		42	150.1	172.8	10.4	142.1	188.9	9.0	(2) ACH 140D	42	155.6	159.0	11.7	147.3	175.0	10.1	
		44	156.3	174.5	10.7	147.9	190.9	9.3		44	161.9	160.5	12.1	153.6	176.5	10.4	
190AA		ACH 130D	42	151.2	190.1	9.1	-	-	-	ACH 225D	42	162.9	184.4	10.6	155.1	203.1	9.2
			44	156.9	202.1	9.3	-	-	-		44	169.4	186.4	10.9	161.4	205.3	9.4
	ACH 140D	42	153.5	198.5	9.3	143.6	217.4	7.9	(2) ACH 110S	42	162.9	171.0	11.4	155.1	189.7	9.8	
		44	159.3	201.4	9.5	149.1	220.2	8.1		44	169.4	173.0	11.8	161.4	191.9	10.1	
	ACH 160D	42	158.0	189.9	10.1	148.0	209.0	8.5	(2) ACH 130D	42	165.2	168.8	11.7	157.4	187.4	10.1	
		44	164.2	192.5	10.2	153.8	211.6	8.7		44	171.8	170.7	12.1	163.8	189.4	10.4	
	ACH 200D	42	160.6	185.9	10.4	152.2	204.9	8.9	(2) ACH 140D	42	166.4	170.5	11.7	158.5	188.9	10.1	
		44	167.3	188.1	10.7	158.3	207.2	9.2		44	173.1	172.3	12.1	165.1	190.8	10.4	

NOTES:

1. Power and EER include unit, condenser fans and control power.
2. Performance may be interpolated between values given in the table.
3. The notation (2) ACH 130D indicates that two ACH 130D condensers are used, one per WGS circuit. Each condenser has two refrigerant circuits that must be manifolded together in the field.
4. A relief must be field installed in the discharge piping.
5. The ratings in this catalog are consistent with the McQuayTools™ selection program version shown inside front cover. For the most up-to-date information, please go to www.mcquay.com.

Table 14, WGS-AA Chillers Matched with McQuay ACX (830 RPM) Air-Cooled Condensers

WGS Model	With Cond	LWT (°F)	Ambient Air Temperature (°F)						With Cond	LWT (°F)	Ambient Air Temperature (°F)						
			95			105					95			105			
			Tons	PWR	EER	Tons	PWR	EER			Tons	PWR	EER	Tons	PWR	EER	
130AA	ACX 100D	42	107.2	144.6	8.9	-	-	-	ACX 160D	42	116.1	132.4	10.5	109.3	145.1	9.0	
		44	111.3	146.7	9.1	-	-	-		44	120.9	133.6	10.9	113.8	146.7	9.3	
	ACX 110D	42	110.6	140.3	9.5	103.4	153.9	8.1	ACX 200D	42	118.3	130.5	10.9	112.0	142.2	9.5	
		44	114.9	142.2	9.7	107.5	155.8	8.3		44	123.1	131.8	11.2	116.7	143.6	9.7	
	ACX 130D	42	112.6	136.7	9.9	105.2	150.4	8.4	ACX 225D	42	120.3	129.0	11.2	114.0	140.6	9.7	
		44	117.0	138.5	10.1	109.5	152.2	8.6		44	125.2	130.2	11.5	118.8	141.9	10.0	
	ACX 140D	42	115.1	134.3	10.3	107.8	147.9	8.7	(2) ACX 110S	42	120.3	121.2	11.9	114.0	132.8	10.3	
		44	119.8	135.7	10.6	112.2	140.5	9.0		44	125.2	122.4	12.3	118.8	134.1	10.6	
	140AA	ACX 100D	42	113.9	160.4	8.5	-	-	-	ACX 160D	42	125.1	144.3	10.4	117.1	159.1	8.8
			44	118.2	163.0	8.7	-	-	-		44	130.1	145.9	10.7	121.8	161.0	9.1
ACX 110D		42	118.1	155.0	9.1	-	-	-	ACX 200D	42	127.3	141.5	10.8	120.4	155.3	9.3	
		44	122.6	157.4	9.3	-	-	-		44	132.6	142.9	11.1	125.3	157.0	9.6	
ACX 130D		42	120.3	150.8	9.6	112.3	165.6	8.1	ACX 225D	42	129.5	139.6	11.1	122.7	153.1	9.6	
		44	125.0	153.0	9.8	116.8	167.9	8.3		44	134.8	140.9	11.5	127.8	154.6	9.9	
ACX 140D		42	123.5	147.4	10.1	115.4	162.3	8.5	(2) ACX 110S	42	129.5	131.8	11.8	122.7	145.3	10.1	
		44	128.3	149.3	10.3	120.0	164.3	8.8		44	134.8	133.1	12.1	127.8	146.8	10.4	
160AA		ACX 110D	42	125.4	170.8	8.8	-	-	-	ACX 200D	42	137.3	154.5	10.7	128.6	169.4	9.1
			44	130.3	173.6	9.0	-	-	-		44	142.8	156.0	11.0	133.9	171.4	9.4
	ACX 130D	42	128.0	166.1	9.2	-	-	-	ACX 225D	42	140.1	152.7	11.0	131.3	166.5	9.5	
		44	133.0	168.6	9.5	-	-	-		44	145.7	154.3	11.3	136.8	168.2	9.8	
	ACX 140D	42	131.5	161.8	9.8	122.9	177.8	8.3	(2) ACX 110S	42	140.1	144.9	11.6	131.3	158.7	9.9	
		44	136.7	164.1	10.0	127.9	180.2	8.5		44	145.7	146.5	11.9	136.8	160.4	10.2	
	ACX 160D	42	133.5	158.0	10.1	124.9	174.1	8.6	(2) ACX 130D	42	142.1	142.3	12.0	133.4	155.9	10.3	
		44	138.8	160.1	10.4	130.0	176.4	8.8		44	147.9	143.8	12.3	138.9	157.5	10.6	
	170AA	ACX 110D	42	133.6	190.8	8.4	-	-	-	ACX 200D	42	147.3	169.2	10.5	138.2	186.6	8.9
			44	138.4	193.9	8.6	-	-	-		44	153.4	171.2	10.8	143.7	188.8	9.1
ACX 130D		42	136.6	185.1	8.9	-	-	-	ACX 225D	42	149.6	166.4	10.8	141.4	182.7	9.3	
		44	141.6	188.0	9.0	-	-	-		44	155.8	168.2	11.1	147.1	184.8	9.6	
ACX 140D		42	140.8	179.5	9.4	131.5	197.1	8.0	(2) ACX 110S	42	149.6	158.6	11.3	141.4	174.9	9.7	
		44	146.1	182.2	9.6	136.5	199.7	8.2		44	155.8	160.4	11.7	147.1	177.0	10.0	
ACX 160D		42	143.2	175.0	9.8	133.8	192.7	8.3	(2) ACX 130D	42	151.8	156.0	11.7	143.8	171.5	10.1	
		44	148.7	177.6	10.0	139.0	195.2	8.5		44	157.9	157.3	12.0	149.7	173.4	10.4	
190AA		ACX 130D	42	145.0	204.4	8.5	-	-	-	ACX 225D	42	160.1	179.9	10.7	151.4	199.0	9.1
			44	150.3	207.8	8.7	-	-	-		44	166.8	182.2	11.0	157.4	201.4	9.4
	ACX 140D	42	149.8	197.5	9.1	-	-	-	(2) ACX 110S	42	160.1	172.1	11.2	151.4	191.2	9.5	
		44	155.4	200.6	9.3	-	-	-		44	166.8	174.4	11.5	157.4	193.6	9.8	
	ACX 160D	42	152.6	192.3	9.5	142.7	211.2	8.1	(2) ACX 130D	42	161.9	168.1	11.6	154.1	187.0	9.9	
		44	158.3	195.2	9.7	148.1	214.0	8.3		44	168.4	170.2	11.9	160.4	182.2	10.2	
	ACX 200D	42	157.8	184.6	10.3	147.7	203.9	8.7	(2) ACX 140D	42	164.5	165.9	11.9	156.6	184.5	10.2	
		44	163.9	187.3	10.5	153.5	206.4	8.9		44	171.0	162.8	12.2	163.0	186.6	10.5	

NOTES:

1. Power and EER include unit, condenser fans and control power.
2. Performance may be interpolated between values given in the table.
3. The notation (2) ACX 130D indicates that two ACX 130D condensers are used, one per WGS circuit. Each condenser has two refrigerant circuits that must be manifolded together in the field.
4. A relief must be field installed in the discharge piping.
5. The ratings in this catalog are consistent with the McQuayTools™ selection program version shown inside front cover. For the most up-to-date information, please go to www.mcquay.com.

Pressure Drops

Figure 8, Evaporator Pressure Drop WGS 130 – WGS 190

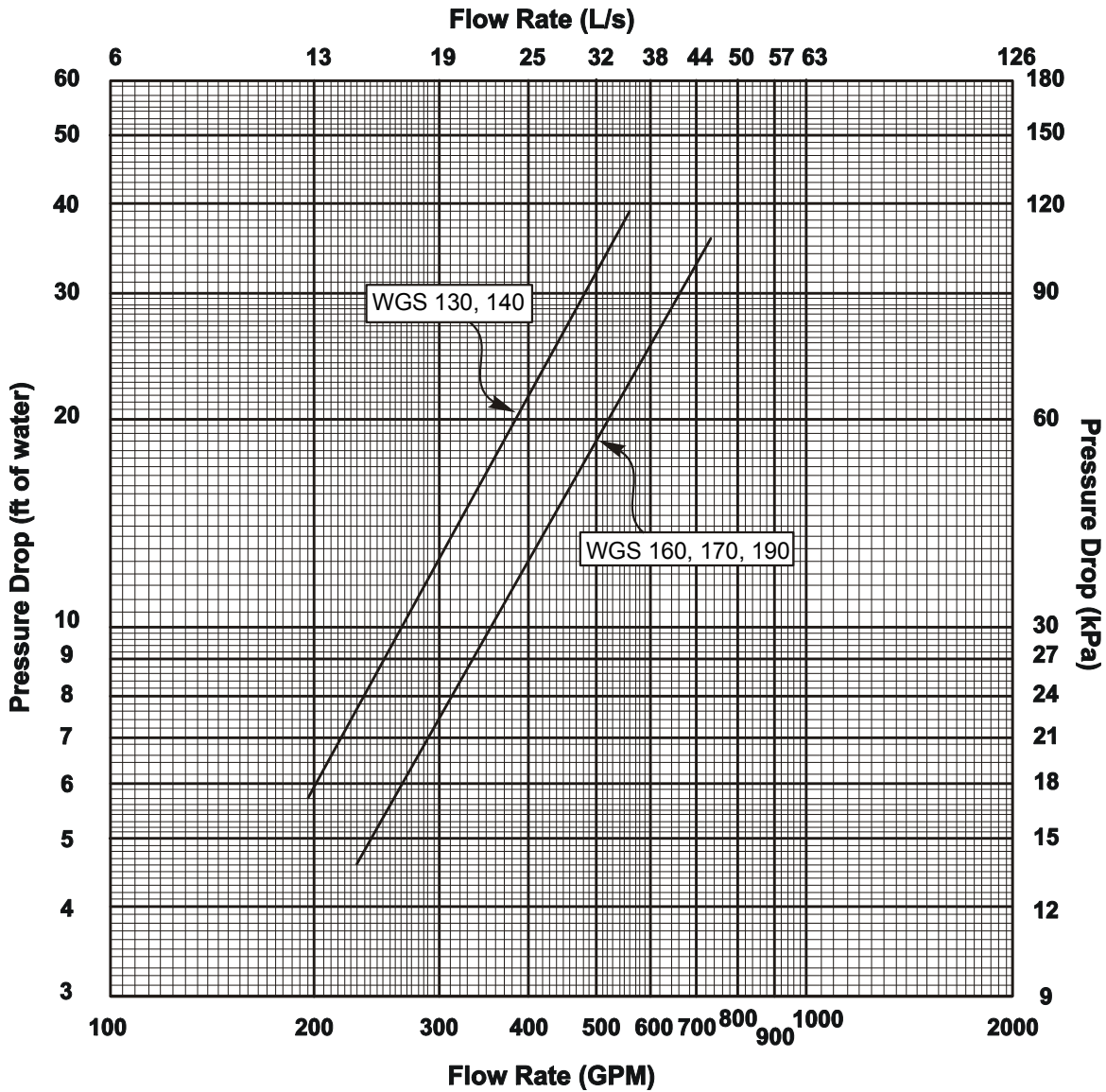

WGS Model	Minimum Flow				Nominal Flow				Maximum Flow			
	Flow Rate		Pressure Drop		Flow Rate		Pressure Drop		Flow Rate		Pressure Drop	
	gpm	L/s	Ft.	kPa	gpm	L/s	Ft.	kPa	gpm	L/s	Ft.	kPa
130AW/AA	195	12.3	5.8	17.4	312	19.7	13.5	40.4	520	32.9	33.9	101.1
140AW/AA	211	13.4	6.7	20.0	338	21.4	15.6	46.6	563	35.6	39.0	116.5
160AW/AA	235	14.9	4.6	13.8	376	23.8	10.8	32.3	627	39.7	27.3	81.6
170AW/AA	254	16.1	5.3	15.9	407	25.8	12.5	37.3	678	42.9	31.6	94.2
190AW/AA	273	17.3	6.1	18.1	437	27.7	14.2	42.5	728	46.1	35.9	107.2

Note: Minimum, nominal, and maximum flows are at a 16°F, 10°F, and 6°F chilled water temperature range respectively and at ARI tons.

Figure 9, Condenser Pressure Drop WGS 130 – WGS 190

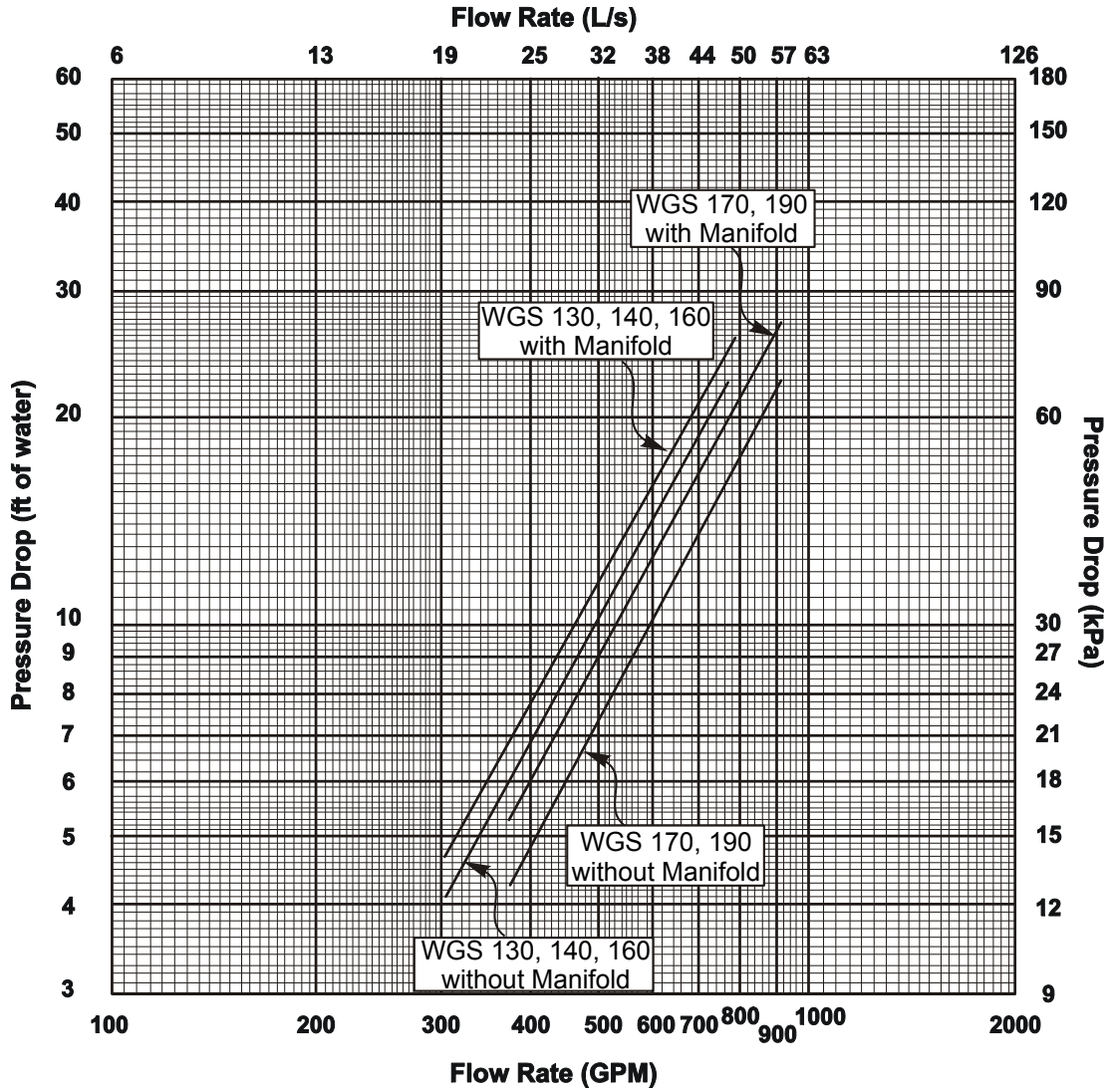

Pressure Drop <i>Without</i> Optional Condenser Manifold												
WGS Model	Minimum Flow				Nominal Flow				Maximum Flow			
	Flow Rate		Pressure Drop		Flow Rate		Pressure Drop		Flow Rate		Pressure Drop	
	gpm	L/s	Ft.	kPa	gpm	L/s	Ft.	kPa	gpm	L/s	Ft.	kPa
130AW	304	19.2	4.1	12.2	390	24.7	6.5	19.3	650	41.1	16.0	47.9
140AW	304	19.2	4.1	12.2	422	26.7	7.4	22.2	704	44.5	18.5	55.1
160AW	304	19.2	4.1	12.2	470	29.8	9.0	26.9	784	49.6	22.4	66.8
170AW	372	23.5	4.3	12.8	509	32.2	7.9	23.7	848	53.7	19.8	59.1
190AW	372	23.5	4.3	12.8	546	34.6	9.0	26.9	911	57.6	22.5	67.1

Pressure Drop <i>With</i> Optional Condenser Manifold												
WGS Model	Minimum Flow				Nominal Flow				Maximum Flow			
	Flow Rate		Pressure Drop		Flow Rate		Pressure Drop		Flow Rate		Pressure Drop	
	gpm	L/s	Ft.	kPa	gpm	L/s	Ft.	kPa	gpm	L/s	Ft.	kPa
130AW	304	19.2	4.7	14.0	390	24.7	7.4	22.0	650	41.1	18.5	55.1
140AW	304	19.2	4.7	14.0	422	26.7	8.5	25.3	704	44.5	21.3	63.5
160AW	304	19.2	4.7	14.0	470	29.8	10.3	30.7	784	49.6	25.8	77.1
170AW	372	23.5	5.3	15.8	509	32.2	9.4	28.1	848	53.7	23.8	71.1
190AW	372	23.5	5.3	15.8	546	34.6	10.7	32.0	911	57.6	27.1	80.9

Electrical Data, Water-cooled

Table 15, WGS 130AW – 190AW, Water-cooled, Electrical Data, Single-Point Connection

WGS UNIT SIZE	VOLTS	MINIMUM CIRCUIT AMPACITY (MCA)	POWER SUPPLY FIELD WIRE		FIELD FUSE SIZE or BREAKER SIZE	
			QTY	MIN. WIRE GAUGE	RECOM-MENDED	MAXIMUM
130AW	208	n/a	n/a	n/a	n/a	n/a
	230	n/a	n/a	n/a	n/a	n/a
	380	243	3	250	300	350
	460	201	3	4/0	225	250
	575	162	3	2/0	200	225
140AW	208	n/a	n/a	n/a	n/a	n/a
	230	n/a	n/a	n/a	n/a	n/a
	380	253	3	250	300	350
	460	209	3	4/0	250	300
	575	169	3	2/0	200	225
160AW	208	n/a	n/a	n/a	n/a	n/a
	230	n/a	n/a	n/a	n/a	n/a
	380	261	3	300	300	350
	460	216	3	4/0	250	300
	575	174	3	2/0	200	250
170AW	208	n/a	n/a	n/a	n/a	n/a
	230	n/a	n/a	n/a	n/a	n/a
	380	276	3	300	350	400
	460	228	3	4/0	300	300
	575	182	3	3/0	225	250
190AW	208	n/a	n/a	n/a	n/a	n/a
	230	n/a	n/a	n/a	n/a	n/a
	380	288	3	350	350	400
	460	237	3	250	300	300
	575	189	3	3/0	225	250

Notes:

1. Table based on 75°C field wire.
2. Complete notes are on page 36.

Table 16, WGS 130AW – WGS 190AW, Water-cooled, Electrical Data, Multiple-Point Connection

WGS UNIT SIZE	VOLTS	ELECTRICAL CIRCUIT 1 (COMP 1)					ELECTRICAL CIRCUIT 2 (COMP 2)				
		MINIMUM CIRCUIT AMPS (MCA)	POWER SUPPLY FIELD WIRE		FIELD FUSING		MINIMUM CIRCUIT AMPS (MCA)	POWER SUPPLY FIELD WIRE		FIELD FUSING	
			QTY	MIN. WIRE GAUGE	REC FUSE SIZE	MAX FUSE SIZE		QTY	MIN. WIRE GAUGE	REC FUSE SIZE	MAX FUSE SIZE
130AW	208	247	3	250	300	400	247	3	250	300	400
	230	223	3	4/0	300	400	223	3	4/0	300	400
	380	135	3	1/0	175	225	135	3	1/0	175	225
	460	112	3	2	150	200	112	3	2	150	200
	575	90	3	3	110	150	90	3	3	110	150
140AW	208	247	3	250	300	400	267	3	300	350	450
	230	223	3	4/0	300	400	240	3	250	300	400
	380	135	3	1/0	175	225	145	3	1/0	175	250
	460	112	3	2	150	200	120	3	1	150	200
	575	90	3	3	110	150	97	3	3	125	150
160AW	208	267	3	300	350	450	267	3	300	350	450
	230	240	3	250	300	400	240	3	250	300	400
	380	145	3	1/0	175	250	145	3	1/0	175	250
	460	120	3	1	150	200	120	3	1	150	200
	575	97	3	3	125	150	97	3	3	125	150
170AW	208	267	3	300	350	450	292	3	350	350	500
	230	240	3	250	300	400	263	3	300	350	450
	380	145	3	1/0	175	250	160	3	2/0	200	250
	460	120	3	1	150	200	132	3	1/0	175	225
	575	97	3	3	125	150	105	3	2	150	175
190AW	208	292	3	350	350	500	292	3	350	350	500
	230	263	3	300	350	450	263	3	300	350	450
	380	160	3	2/0	200	250	160	3	2/0	200	250
	460	132	3	1/0	175	225	132	3	1/0	175	225
	575	105	3	2	150	175	105	3	2	150	175

Notes:

1. Table based on 75°C field wire.
2. Complete notes are on page 36.

Table 17, WGS 130AW – WGS 190AW, Water-cooled, Compressor Amp Draw

WGS UNIT SIZE	VOLTS	RATED LOAD AMPS		WGS UNIT SIZE	VOLTS	RATED LOAD AMPS	
		CIRCUIT #1	CIRCUIT #2			CIRCUIT #1	CIRCUIT #2
130AW	208	197	197	170AW	208	213	233
	230	178	178		230	192	210
	380	108	108		380	116	128
	460	89	89		460	96	105
	575	72	72		575	77	84
140AW	208	197	213	190AW	208	233	233
	230	178	192		230	210	210
	380	108	116		380	128	128
	460	89	96		460	105	105
	575	72	77		575	84	84
160AW	208	213	213				
	230	192	192				
	380	116	116				
	460	96	96				
	575	77	77				

Table 18, WGS 130AW – 190AW, Water-cooled, Field Wiring with Single-Point Power

WGS UNIT SIZE	VOLTS	WIRING TO STANDARD UNIT POWER BLOCK		WIRING TO OPTIONAL NONFUSED DISCONNECT SWITCH IN UNIT	
		TERMINAL SIZE AMPS	CONNECTOR LUG RANGE PER PHASE (COPPER WIRE ONLY)	SIZE AMPS	CONNECTOR LUG RANGE PER PHASE (COPPER WIRE ONLY)
130AW	208	n/a	n/a	n/a	n/a
	230	n/a	n/a	n/a	n/a
	380	400	#6-350	400	3/0-500
	460	400	#6-350	250	#6-350
	575	400	#6-350	250	#6-350
140AW	208	n/a	n/a	n/a	n/a
	230	n/a	n/a	n/a	n/a
	380	400	#6-350	400	3/0-500
	460	400	#6-350	250	#6-350
	575	400	#6-350	250	#6-350
160AW	208	n/a	n/a	n/a	n/a
	230	n/a	n/a	n/a	n/a
	380	400	#6-350	400	3/0-500
	460	400	#6-350	250	#6-350
	575	400	#6-350	250	#6-350
170AW	208	n/a	n/a	n/a	n/a
	230	n/a	n/a	n/a	n/a
	380	400	#6-350	400	3/0-500
	460	400	#6-350	250	#6-350
	575	400	#6-350	250	#6-350
190AW	208	n/a	n/a	n/a	n/a
	230	n/a	n/a	n/a	n/a
	380	400	#6-350	400	3/0-500
	460	400	#6-350	250	#6-350
	575	400	#6-350	250	#6-350

Table 19, WGS 130AW – 190AW, Wiring to Multiple-Point Power Block

WGS UNIT SIZE	VOLTS	WIRING TO UNIT POWER BLOCK			
		TERMINAL SIZE (AMPS)		CONNECTOR WIRE RANGE PER PHASE (COPPER WIRE ONLY)	
		CKT 1	CKT 2	CKT 1	CKT 2
130AW	208	400	400	#6-350	#6-350
	230	400	400	#6-350	#6-350
	380	400	400	#6-350	#6-350
	460	400	400	#6-350	#6-350
	575	400	400	#6-350	#6-350
14-AW	208	400	400	#6-350	#6-350
	230	400	400	#6-350	#6-350
	380	400	400	#6-350	#6-350
	460	400	400	#6-350	#6-350
	575	400	400	#6-350	#6-350
160AW	208	400	400	#6-350	#6-350
	230	400	400	#6-350	#6-350
	380	400	400	#6-350	#6-350
	460	400	400	#6-350	#6-350
	575	400	400	#6-350	#6-350
170AW	208	400	400	#6-350	#6-350
	230	400	400	#6-350	#6-350
	380	400	400	#6-350	#6-350
	460	400	400	#6-350	#6-350
	575	400	400	#6-350	#6-350
190AW	208	400	400	#6-350	#6-350
	230	400	400	#6-350	#6-350
	380	400	400	#6-350	#6-350
	460	400	400	#6-350	#6-350
	575	400	400	#6-350	#6-350

**Table 20, WGS 130AW – 190AW, Water-cooled,
Wiring to Multiple-Point Disconnect Switch**

WGS UNIT SIZE	VOLTS	WIRING TO UNIT DISCONNECT SWITCH			
		TERMINAL SIZE (AMPS)		CONNECTOR WIRE RANGE PER PHASE (COPPER WIRE ONLY)	
		CKT 1	CKT 2	CKT 1	CKT 2
130AW	208	250	250	#6-350	#6-350
	230	250	250	#6-350	#6-350
	380	250	250	#6-350	#6-350
	460	250	250	#6-350	#6-350
	575	250	250	#6-350	#6-350
140AW	208	250	400	#6-350	3/0-500
	230	250	250	#6-350	#6-350
	380	250	250	#6-350	#6-350
	460	250	250	#6-350	#6-350
	575	250	250	#6-350	#6-350
160AW	208	400	400	3/0-500	3/0-500
	230	250	250	#6-350	#6-350
	380	250	250	#6-350	#6-350
	460	250	250	#6-350	#6-350
	575	250	250	#6-350	#6-350
170AW	208	400	400	3/0-500	3/0-500
	230	250	400	#6-350	3/0-500
	380	250	250	#6-350	#6-350
	460	250	250	#6-350	#6-350
	575	250	250	#6-350	#6-350
190AW	208	400	400	3/0-500	3/0-500
	230	400	400	3/0-500	3/0-500
	380	250	250	#6-350	#6-350
	460	250	250	#6-350	#6-350
	575	250	250	#6-350	#6-350

Electrical Data, Remote Condenser

**Table 21, WGS 130AA– WGS 190AA, Remote Condenser,
Electrical Data, Single-Point Connection**

WGS UNIT SIZE	VOLTS	MINIMUM CIRCUIT AMPACITY (MCA)	POWER SUPPLY		FIELD FUSE SIZE or BREAKER SIZE	
			FIELD WIRE		RECOM- MENDED	MAXIMUM
			QTY	MIN. WIRE GAUGE		
130AA	208	n/a	n/a	n/a	n/a	n/a
	230	n/a	n/a	n/a	n/a	n/a
	380	n/a	n/a	n/a	n/a	n/a
	460	252	3	250 MCM	300	350
	575	192	3	3/0 AWG	225	250
140AA	208	n/a	n/a	n/a	n/a	n/a
	230	n/a	n/a	n/a	n/a	n/a
	380	n/a	n/a	n/a	n/a	n/a
	460	265	3	300 MCM	300	350
	575	203	3	4/0 AWG	250	250
160AA	208	n/a	n/a	n/a	n/a	n/a
	230	n/a	n/a	n/a	n/a	n/a
	380	n/a	n/a	n/a	n/a	n/a
	460	275	3	300 MCM	350	350
	575	212	3	4/0 AWG	250	300
170AA	208	n/a	n/a	n/a	n/a	n/a
	230	n/a	n/a	n/a	n/a	n/a
	380	n/a	n/a	n/a	n/a	n/a
	460	299	3	350 MCM	350	400
	575	236	3	250 MCM	300	300
190AA	208	n/a	n/a	n/a	n/a	n/a
	230	n/a	n/a	n/a	n/a	n/a
	380	n/a	n/a	n/a	n/a	n/a
	460	318	3	(2) 250 MCM	400	450
	575	255	3	250 MCM	300	350

Notes:

1. Table based on 75°C field wire.
2. Complete notes are on page 36.

Table 22, WGS 130–190, Remote Condenser, Electrical Data, Multiple-Point Connection

WGS UNIT SIZE	VOLTS	ELECTRICAL CIRCUIT 1 (COMP 1)					ELECTRICAL CIRCUIT 2 (COMP 2)				
		MINIMUM CIRCUIT AMPS (MCA)	POWER SUPPLY		FIELD FUSING		MINIMUM CIRCUIT AMPS (MCA)	POWER SUPPLY		FIELD FUSING	
			FIELD WIRE		REC. FUSE SIZE	MAX FUSE SIZE		FIELD WIRE		REC. FUSE SIZE	MAX FUSE SIZE
			QTY	MIN. WIRE GAUGE				QTY	MIN. WIRE GAUGE		
130AA	208	290	3	350	350	500	290	3	350	350	500
	230	263	3	300	350	450	263	3	300	350	450
	380	160	3	2/0	200	250	160	3	2/0	200	250
	460	140	3	1/0	175	250	140	3	1/0	175	250
	575	107	3	2	150	175	107	3	2	150	175
140AA	208	290	3	350	350	500	334	3	2-250	450	600
	230	263	3	300	350	450	300	3	350	400	500
	380	160	3	2/0	200	250	182	3	3/0	225	300
	460	140	3	1/0	175	250	153	3	2/0	200	250
	575	107	3	2	150	175	118	3	1	150	200
160AA	208	334	3	2-250	450	600	334	3	2-250	450	600
	230	300	3	350	400	500	300	3	350	400	500
	380	182	3	3/0	225	300	182	3	3/0	225	300
	460	153	3	2/0	200	250	153	3	2/0	200	250
	575	118	3	1	150	200	118	3	1	150	200
170AA	208	334	3	2-250	450	600	390	6	2-250	500	700
	230	300	3	350	400	500	353	3	2-250	450	600
	380	182	3	3/0	225	300	223	3	4/0	300	400
	460	153	3	2/0	200	250	177	3	3/0	225	300
	575	118	3	1	150	200	142	3	1/0	175	250
190AA	208	390	6	2-250	500	700	390	6	2-250	500	700
	230	353	3	2-250	450	600	353	3	2-250	450	600
	380	223	3	4/0	300	400	223	3	4/0	300	400
	460	177	3	3/0	225	300	177	3	3/0	225	300
	575	142	3	1/0	175	250	142	3	1/0	175	250

Notes:

1. Table based on 75°C field wire.
2. Complete notes are on page 36.
3. 3/0 wire is required for the disconnect switch option, 2/0 may be used for power block connection.

Table 23, WGS 130–190, Remote Condenser, Compressor Amp Draw

WGS UNIT SIZE	VOLTS	RATED LOAD AMPS		WGS UNIT SIZE	VOLTS	RATED LOAD AMPS	
		CIRCUIT #1	CIRCUIT #2			CIRCUIT #1	CIRCUIT #2
130AA	208	232	232	170AA	208	267	312
	230	210	210		230	240	282
	380	128	128		380	145	178
	460	112	112		460	122	141
	575	85	85		575	94	113
140AA	208	232	267	190AA	208	312	312
	230	210	240		230	282	282
	380	128	145		380	178	178
	460	112	122		460	141	141
	575	85	94		575	113	113
160AA	208	267	267				
	230	240	240				
	380	145	145				
	460	122	122				
	575	94	94				

Table 24, WGS 130AA – 190AA, Remote Condenser, Field Wiring with Single-Point Power

WGS UNIT SIZE	VOLTS	WIRING TO STANDARD UNIT POWER BLOCK		WIRING TO OPTIONAL NONFUSED DISCONNECT SWITCH IN UNIT	
		TERMINAL SIZE AMPS	CONNECTOR LUG RANGE PER PHASE (COPPER WIRE ONLY)	SIZE AMPS	CONNECTOR LUG RANGE PER PHASE (COPPER WIRE ONLY)
130AA	208	n/a	n/a	n/a	n/a
	230	n/a	n/a	n/a	n/a
	380	n/a	n/a	n/a	n/a
	460	400	#6-350	400	3/0-500
	575	400	#6-350	250	#6-350
140AA	208	n/a	n/a	n/a	n/a
	230	n/a	n/a	n/a	n/a
	380	n/a	n/a	n/a	n/a
	460	400	#6-350	400	3/0-500
	575	400	#6-350	250	#6-350
160AA	208	n/a	n/a	n/a	n/a
	230	n/a	n/a	n/a	n/a
	380	n/a	n/a	n/a	n/a
	460	400	#6-350	400	3/0-500
	575	400	#6-350	250	#6-350
170AA	208	n/a	n/a	n/a	n/a
	230	n/a	n/a	n/a	n/a
	380	n/a	n/a	n/a	n/a
	460	400	#6-350	400	3/0-500
	575	400	#6-350	250	#6-350
190AA	208	n/a	n/a	n/a	n/a
	230	n/a	n/a	n/a	n/a
	380	n/a	n/a	n/a	n/a
	460	400	#6-350	400	3/0-500
	575	400	#6-350	400	3/0-500

Table 25, WGS 130AA to 190AA, Wiring to Multiple-Point Power Block

WGS UNIT SIZE	VOLTS	WIRING TO UNIT POWER BLOCK			
		TERMINAL SIZE (AMPS)		CONNECTOR WIRE RANGE PER PHASE (COPPER WIRE ONLY)	
		CKT 1	CKT 2	CKT 1	CKT 2
130AA	208	400	400	#6-350	#6-350
	230	400	400	#6-350	#6-350
	380	400	400	#6-350	#6-350
	460	400	400	#6-350	#6-350
	575	400	400	#6-350	#6-350
140AA	208	400	400	#6-350	#6-350
	230	400	400	#6-350	#6-350
	380	400	400	#6-350	#6-350
	460	400	400	#6-350	#6-350
	575	400	400	#6-350	#6-350
160AA	208	400	400	#6-350	#6-350
	230	400	400	#6-350	#6-350
	380	400	400	#6-350	#6-350
	460	400	400	#6-350	#6-350
	575	400	400	#6-350	#6-350
170AA	208	400	400	#6-350	#6-350
	230	400	400	#6-350	#6-350
	380	400	400	#6-350	#6-350
	460	400	400	#6-350	#6-350
	575	400	400	#6-350	#6-350
190AA	208	400	400	#6-350	#6-350
	230	400	400	#6-350	#6-350
	380	400	400	#6-350	#6-350
	460	400	400	#6-350	#6-350
	575	400	400	#6-350	#6-350

**Table 26, WGS 130AA – 190AA, Remote Condenser,
Wiring to Multiple-Point Disconnect Switch**

WGS UNIT SIZE	VOLTS	WIRING TO UNIT DISCONNECT SWITCH			
		TERMINAL SIZE (AMPS)		CONNECTOR WIRE RANGE PER PHASE (COPPER WIRE ONLY)	
		CKT 1	CKT 2	CKT 1	CKT 2
130AA	208	400	400	3/0-500	3/0-500
	230	400	400	3/0-500	3/0-500
	380	250	250	#6-350	#6-350
	460	250	250	#6-350	#6-350
	575	250	250	#6-350	#6-350
140AA	208	400	400	3/0-500	3/0-500
	230	400	400	3/0-500	3/0-500
	380	250	250	#6-350	#6-350
	460	250	250	#6-350	#6-350
	575	250	250	#6-350	#6-350
160AA	208	400	400	3/0-500	3/0-500
	230	400	400	3/0-500	3/0-500
	380	250	250	#6-350	#6-350
	460	250	250	#6-350	#6-350
	575	250	250	#6-350	#6-350
170AA	208	400	400	3/0-500	3/0-500
	230	400	400	3/0-500	3/0-500
	380	250	250	#6-350	#6-350
	460	250	250	#6-350	#6-350
	575	250	250	#6-350	#6-350
190AA	208	400	400	3/0-500	3/0-500
	230	400	400	3/0-500	3/0-500
	380	250	250	#6-350	#6-350
	460	250	250	#6-350	#6-350
	575	250	250	#6-350	#6-350

Notes for “Electrical Data Single/Multiple Point” Power:

1. Wire sizing amps is 10 amps if a separate 115V power supply is used.
2. Unit wire size ampacity is equal to 125% of the largest compressor motor, plus 100% of the RLA of all other loads in the circuit, including the control transformer.
3. Recommended power lead wire sizes for 3 conductors per conduit are based on 100% conductor ampacity in accordance with NEC. Voltage drop has not been included. Therefore, power leads should be kept short. All terminal block connections must be made with copper (type THW) wire.
4. The recommended power lead wire sizes are based on an ambient temperature of 86°F (30°C). Ampacity correction factors must be applied for other ambient temperatures. Refer to the National Electrical Code Handbook.
5. The recommended fuse size or HACR circuit breaker size is equal to 150% of the largest compressor motor RLA plus 100% of the remaining compressor RLA.
6. The maximum fuse size or HACR circuit breaker size is equal to 225% of the largest compressor motor RLA plus 100% of the remaining compressor RLA.
7. Must be electrically grounded according to national and local electrical codes.

Power Limitations:

1. Voltage within ± 10 percent of nameplate rating.
2. Voltage unbalance not to exceed 2% with a resultant current unbalance of 6 to 10 times the voltage unbalance per NEMA MG-1, 1998 Standard.

Notes for “Electrical Data”

1. Requires a disconnect switch per circuit to supply electrical power to the unit. If field supplied, this power supply must either be fused or use an HACR type circuit breaker.
2. All field wiring to unit power block or optional non-fused disconnect switch must be copper.
3. All field wire size values given in table apply to 75°C rated wire per NEC.

Notes for Wiring Diagram

On remote condenser units, head pressure control by cycling fans can be accomplished several ways. The MicroTech II controller in the unit can be used. It senses discharge pressure and will stage up to 6 condenser fans when wired in accordance with Figure 11 on page 38. If the condenser has more than 6 fans, 2 can be operated on a step. For example, a condenser with 10 fans would have 2 fans on steps #1 through #4 and one fan each on steps #5 and #6. Condensers with less than 6 fans would use the appropriate MicroTech II controller steps beginning with #1.

Wire so that the first-on, last-off fan stage has one fan on it.

The McQuay ACD condensers have unit-mounted and wired single fan motor VFD combined with fan cycling by pressure switches for the balance of the fans available as an option. They can be used for staging fans instead of the WGS MicroTech II controller.

Circuit Breakers

The circuit breaker used in the High Short Circuit panel option may have a higher trip rating than the unit Maximum Overload Protection (MOP) value shown on the unit nameplate. The circuit breaker is installed as a service disconnect switch and does not function as branch circuit protection, mainly that the protection device must be installed at the point of origin of the power wiring. The breaker (disconnect switch) is oversized to avoid nuisance trips at high ambient temperature conditions.

Field Wiring Diagrams

**Figure 10, WGS 130–190 AW Field Wiring Diagram
(Optional Single-point Connection to Power Block Shown)**

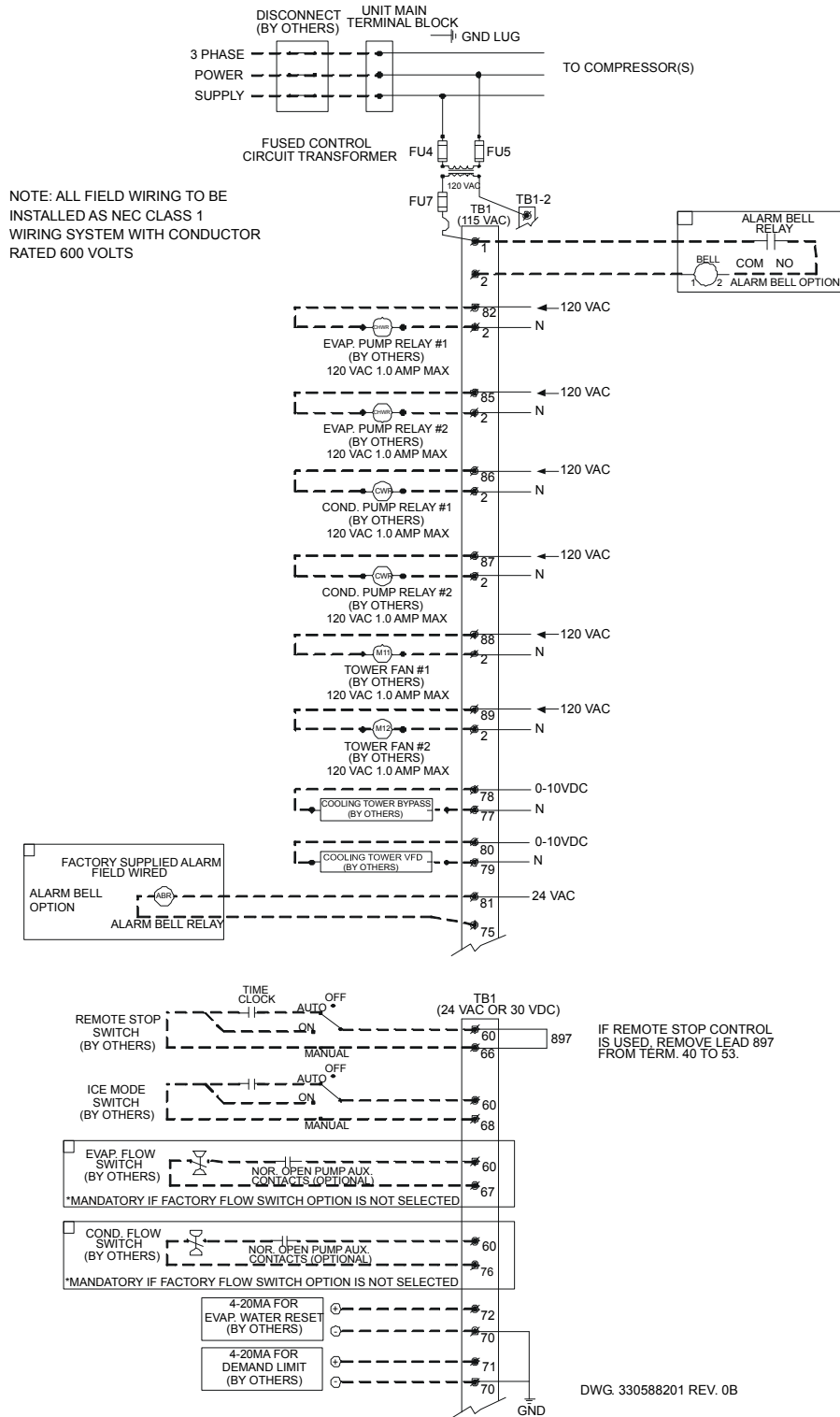

See "Notes for Wiring Diagram" on page 36.

Figure 11, WGS 130AA – 190AA Field Wiring Diagram (Remote Condenser)
(Optional Single-point Connection to Power Block Shown)

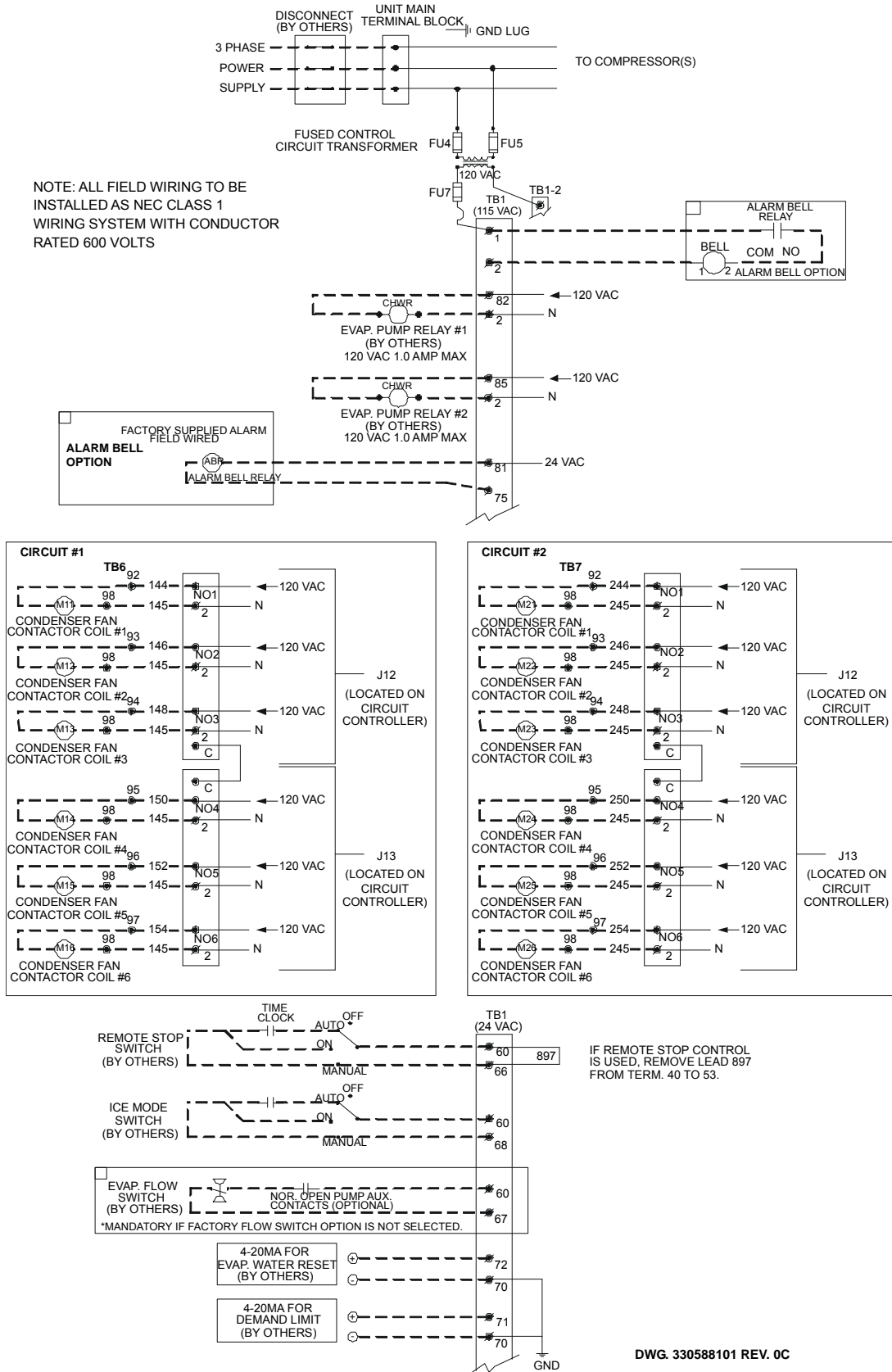

See "Notes for Wiring Diagram" on page 36.

Physical Data

WGS-AW, Water-Cooled

Table 27, WGS-130AW - WGS-190AW

WGS UNIT SIZE	130AW		140AW		160AW		170AW		190AW	
Unit capacity @ ARI conditions tons, (kW) (1)	130.0 (457.1)		140.7 (494.7)		156.7 (551.0)		169.6 (596.3)		182.1 (640.3)	
No. Circuits	2		2		2		2		2	
COMPRESSORS, Frame 3										
Nominal Horsepower	65	65	65	80	80	80	80	95	95	95
Number (2)	1	1	1	1	1	1	1	1	1	1
% Min Capacity (Modulated) (4)	15		13/17		15		14/16		15	
Oil Charge per Compressor oz., (l)	256 (7.6)		256 (7.6)		256 (7.6)		256 (7.6)		256 (7.6)	
CONDENSER										
Number	2		2		2		2		2	
No. Refrigerant Circuits per cond.	1		1		1		1		1	
Diameter, in., (mm)	12 (305)		12 (305)		12 (305)		12 (305)		12 (305)	
Tube Length, in., (mm)	120 (3048)		120 (3048)		120 (3048)		120 (3048)		120 (3048)	
Design W.P. psig, (kPa):										
Refrigerant Side	350 (2413)		350 (2413)		350 (2413)		350 (2413)		350 (2413)	
Water Side	225 (1551)		225 (1551)		225 (1551)		225 (1551)		225 (1551)	
No. of Passes	2		2		2		2		2	
Pump-Out Capacity per Circuit, lb., (kg) (3)	330 (150)		330 (150)		330 (150)		296 (134)		296 (134)	
Connections:										
Water In & Out, in, (mm) victaulic	4.0 (101)		4.0 (101)		4.0 (101)		4.0 (101)		4.0 (101)	
Relief Valve, In., (mm)	0.5 (12.7)		0.5 (12.7)		0.5 (12.7)		0.5 (12.7)		0.5 (12.7)	
Purge Valve, Flare In., (mm)	.625 (15.9)		.625 (15.9)		.625 (15.9)		.625 (15.9)		.625 (15.9)	
Vent & Drain, in. (mm) FPT	0.5 (12.7)		0.5 (12.7)		0.5 (12.7)		0.5 (12.7)		0.5 (12.7)	
Liquid Subcooling	Integral		Integral		Integral		Integral		Integral	
EVAPORATOR										
Number	1		1		1		1		1	
No. Refrigerant Circuits	2		2		2		2		2	
Water Volume, gallons, (l)	68 (257)		68 (257)		115 (435)		115 (435)		115 (435)	
Refrig. Side D.W.P., psig, (kPa)	354 (2441)		354 (2441)		354 (2441)		354 (2441)		354 (2441)	
Water Side D.W.P., psig, (kPa)	150 (1034)		150 (1034)		150 (1034)		150 (1034)		150 (1034)	
Water Connections:										
Inlet & Outlet, in., (mm) victaulic	6.0 (152)		6.0 (152)		8.0 (203)		8.0 (203)		8.0 (203)	
Drain & Vent (NPT INT.)	0.5		0.5		0.5		0.5		0.5	
UNIT DIMENSIONS (5)										
Length In., (mm)	169.9 (4315)		169.9 (4315)		169.9 (4315)		169.9 (4315)		169.9 (4315)	
Width In., (mm)	34.0 (864)		34.0 (864)		34.0 (864)		34.0 (864)		34.0 (864)	
Height In., (mm)	74.6 (1895)		74.6 (1895)		76.6 (1946)		76.6 (1946)		76.6 (1946)	
UNIT WEIGHTS										
Operating Weight, lb., (kg)	8557 (3881)		8557 (3881)		9314 (4225)		9505 (4311)		9505 (4311)	
Shipping Weight, lb., (kg)	7840 (3556)		7840 (3556)		8206 (3722)		8345 (3785)		8345 (3785)	
Operating Charge per Circuit, R-134a, lb., (kg)	127 (58)		127 (58)		128 (58)		124 (56)		124 (56)	

Notes:

1. Certified in accordance with ARI Standard 550/590-98.
2. All units have one compressor per circuit.
3. 80% full R-134a at 90°F (32°C) per refrigerant circuit.
4. On units with mixed capacity compressors, the minimum capacity depends on which compressor is lag.
5. Without sound enclosure-see dimension drawing for enclosure dimensions.

WGS-AA Remote Condenser

Table 28, WGS-130AA - WGS-190AA

WGS UNIT SIZE	130AA		140AA		160AA		170AA		190AA	
Unit capacity @ 44°F LWT, 125°F SDT, tons, (kW)	116.0 (407.9)		125.9 (442.7)		136.1 (478.6)		148.0 (520.4)		160.1 (562.9)	
No. Circuits	2		2		2		2		2	
COMPRESSORS, FRAME 3										
Nominal Horsepower	65	65	65	80	80	80	80	95	95	95
Number (1)	1	1	1	1	1	1	1	1	1	1
% Min. Capacity (Modulated) (2)	15		13/17		15		14/16		15	
Oil Charge per Compressor oz., (l)	256 (7.6)		256 (7.6)		256 (7.6)		256 (7.6)		256 (7.6)	
CONDENSER (Remote)										
EVAPORATOR										
Number	1		1		1		1		1	
No. Refrigerant Circuits	2		2		2		2		2	
Water Volume, gallons, (l)	68 (257)		68 (257)		115 (435)		115 (435)		115 (435)	
Refrig. Side D.W.P., psig, (kPa)	354 (2441)		354 (2441)		354 (2441)		354 (2441)		354 (2441)	
Water Side D.W.P., psig, (kPa)	150 (1034)		150 (1034)		150 (1034)		150 (1034)		150 (1034)	
Water Connections:										
Inlet & Outlet, in., (mm) victaulic	6.0 (152)		6.0 (152)		8.0 (203)		8.0 (203)		8.0 (203)	
Drain & Vent (NPT INT.)	0.5		0.5		0.5		0.5		0.5	
UNIT DIMENSIONS (4)										
Length In., (mm)	179.3 (4554)		179.3 (4554)		179.3 (4554)		179.3 (4554)		179.3 (4554)	
Width In., (mm)	34.0 (864)		34.0 (864)		34.0 (864)		34.0 (864)		34.0 (864)	
Height In., (mm)	60.8 (1544)		60.8 (1544)		62.8 (1595)		62.8 (1595)		62.8 (1595)	
UNIT WEIGHTS (5)										
Operating Weight, lb., (kg)	6265 (2841)		6265 (2841)		7022 (3185)		7022 (3185)		7022 (3185)	
Shipping Weight, lb., (kg)	5659 (2567)		5659 (2567)		6024 (2732)		6024 (2732)		6024 (2732)	
Operating Charge, lb., (kg) (3)	35 (15.9)		35 (15.9)		36 (16.5)		36 (16.5)		36 (16.5)	

Note:

1. All units have one compressor per circuit.
2. On units with mixed capacity compressors, the minimum capacity depends on which compressor is lag.
3. Indoor unit only. Does not include field piping or condenser charge. System charge of R-134a supplied by the installing contractor.
4. Without sound enclosure-see dimension drawing for enclosure dimensions.
5. Add 650 lbs (295 kg) for sound enclosure.

Dimensional Data

WGS-AW Water-Cooled

**Figure 12, WGS 130AW through WGS 190AW Packaged Chiller
Without Optional Condenser Water Manifolds**

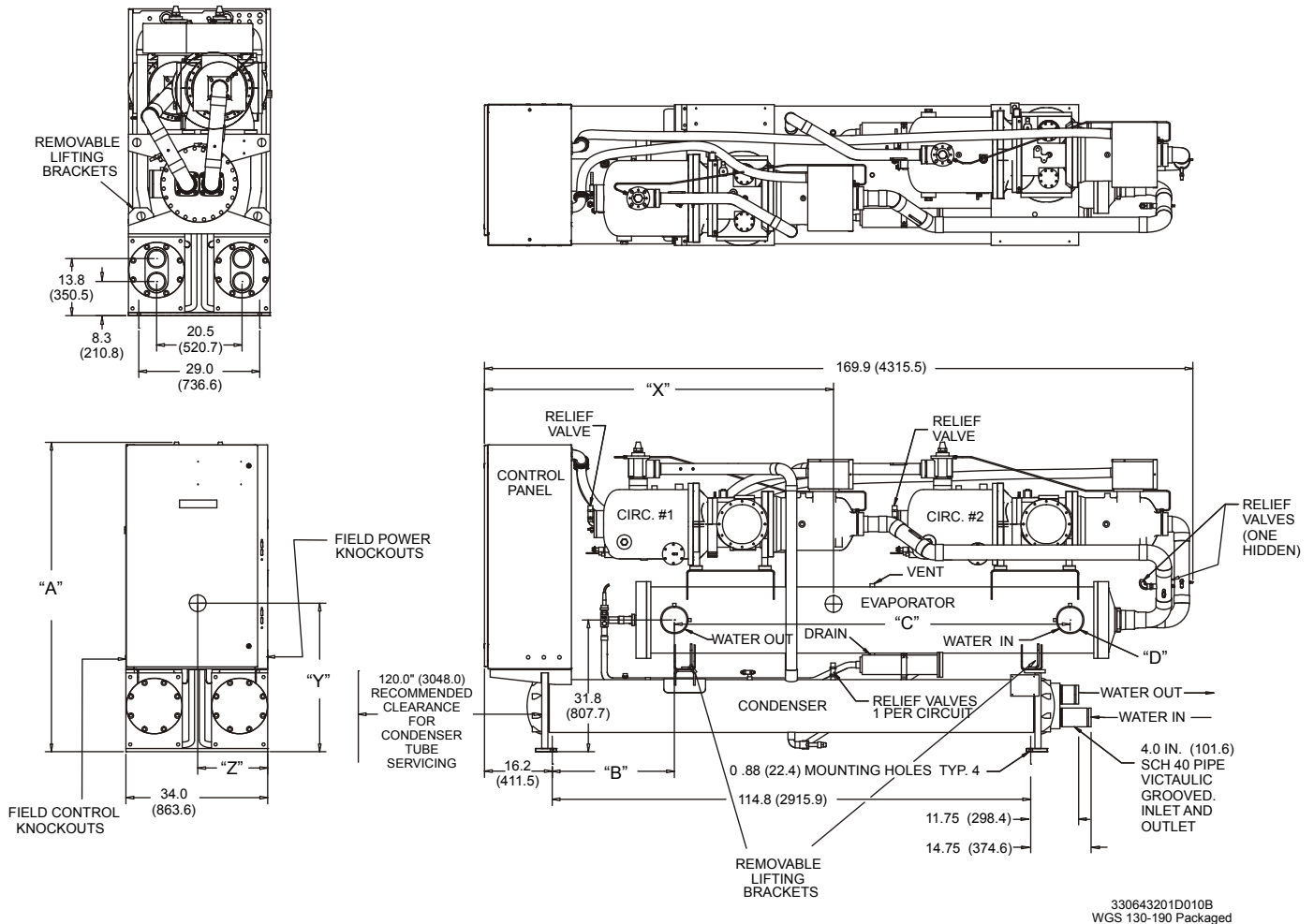

Notes:

1. Unit water connection handing is oriented facing the control panel.
2. Unit shown with standard right-hand evaporator connections. Left-hand available as option.
3. Condenser connections available only as shown.

WGS Models	Dimensions Inches (mm)			Evaporator Victualic Inches (mm)	Center of Gravity Inches (mm)			Additions for Sound Enclosure Inches (mm)		
	"A"	"B"	"C"		"D"	"X"	"Y"	"Z"	Length	Width
WGS 130AW-140AW	74.6 (1894.8)	29.3 (744.2)	95.0 (2413.0)	6.0 (152.4)	83.9 (2131.1)	35.8 (909.3)	16.8 (426.7)	4.0 (101.6)	2.5 (63.5)	3.0 (76.2)
WGS 160AW-190AW	76.6 (1945.6)	30.4 (772.2)	92.9 (2359.6)	8.0 (203.2)	84.0 (2133.6)	36.0 (914.4)	16.8 (426.7)	4.0 (101.6)	2.5 (63.5)	5.0 (127.0)

WGS-AW, Water-Cooled with Optional Condenser Manifolds

Figure 13 WGS 130AW through 190AW with Optional Condenser Manifolds

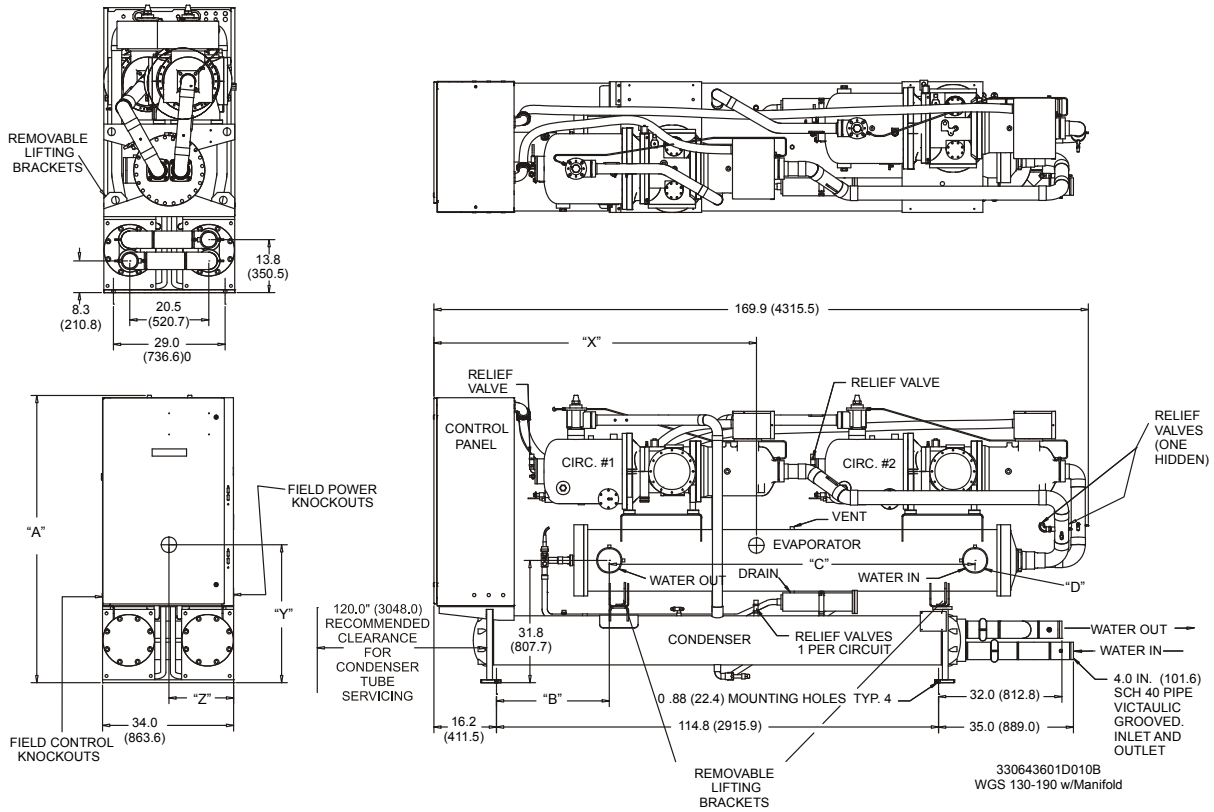

Notes:

1. Unit water connection handing is oriented facing the control panel.
2. Unit shown with standard right-hand evaporator connections. Left-hand available as option.
3. Condenser connections available only as shown.

WGS Models	Dimensions Inches (mm)			Evaporator Victualic Inches (mm)	Center of Gravity Inches (mm)			Additions for Sound Enclosure Inches (mm)		
	"A"	"B"	"C"		"D"	"X"	"Y"	"Z"	Length	Width
WGS 130AW-140AW	74.6 (1894.8)	29.3 (744.2)	95.0 (2413.0)	6.0 (152.4)	83.9 (2131.1)	35.8 (909.3)	16.8 (426.7)	4.0 (101.6)	2.5 (63.5)	3.0 (76.2)
WGS 160AW-190AW	76.6 (1945.6)	30.4 (772.2)	92.9 (2359.6)	8.0 (203.2)	84.0 (2133.6)	36.0 (914.4)	16.8 (426.7)	4.0 (101.6)	2.5 (63.5)	5.0 (127.0)

WGS-AA Remote Condenser

Figure 14, Dimensions, WGS 130AA through WGS 190AA Remote Condenser

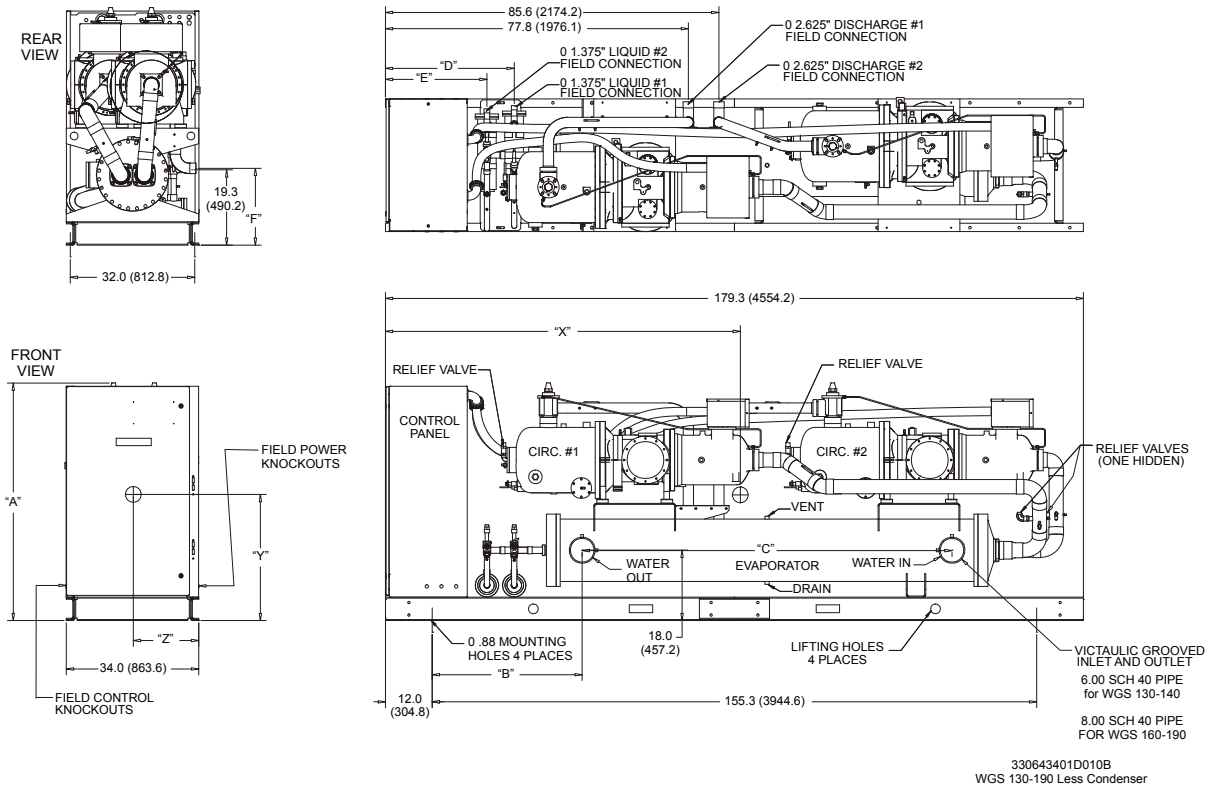

Notes:

1. Unit water connection handing is oriented facing the control panel.
2. Unit shown has standard right hand evaporator water connections. Left-hand available as option.

WGS Models	Dimensions Inches (mm)						Center of Gravity Inches (mm)			Additions for Sound Enclosure Inches (mm)		
	"A"	"B"	"C"	"D"	"E"	"F"	"X"	"Y"	"Z"	Length	Width	Height
WGS 130-140AW	60.8 (1544.3)	38.1 (967.7)	95.0 (2413.0)	33.1 (840.7)	26.1 (662.9)	19.7 (500.4)	92.3 (2344.4)	32.3 (820.4)	16.8 (426.7)	4.0 (101.6)	2.5 (63.5)	3.0 (76.2)
WGS 160-190AW	62.8 (1595.1)	39.6 (1005.8)	92.9 (2359.7)	32.7 (830.6)	25.7 (652.8)	21.7 (551.2)	92.5 (2349.5)	32.5 (825.5)	16.7 (424.2)	4.0 (101.6)	2.5 (63.5)	5.0 (127.0)

Sound Data

Table 29, WGS Sound Power without Sound Insulation

WGS Unit Size	Octave Band Sound Power Levels Per ARI Standard 575 (dB)								Overall "A" Weighted
	63 Hz	125 Hz	250 Hz	500 Hz	1000 Hz	2000 Hz	4000 Hz	8000 Hz	
130	44	53	49	61	71	80	64	55	83
140	44	54	50	61	72	81	65	56	84
160	45	54	50	62	72	81	65	56	84
170	45	55	51	62	73	82	66	57	85
190	46	55	51	63	73	82	66	57	85

Notes: Sound Power per ARI Standard 575.

Table 30, WGS Sound Power with Sound Insulation

WGS Unit Size	Octave Band Sound Power Levels Per ARI Standard 575 (dB)								Overall "A" Weighted
	63 Hz	125 Hz	250 Hz	500 Hz	1000 Hz	2000 Hz	4000 Hz	8000 Hz	
130	44	52	49	59	67	75	63	51	78
140	44	53	50	60	67	75	63	52	79
160	45	53	50	60	68	76	64	52	79
170	45	54	51	61	68	76	64	53	80
190	46	54	51	61	69	77	65	53	80

Notes: Sound Power per ARI Standard 575.

Table 31, WGS Sound Pressure without Sound Insulation

WGS Unit Size	Octave Band Sound Power Levels Per ARI Standard 575 (dB)								Overall "A" Weighted
	62 Hz	125 Hz	250 Hz	500 Hz	1000 Hz	2000 Hz	4000 Hz	8000 Hz	
130	36	45	42	53	64	72	57	47	74
140	36	46	42	53	64	73	57	48	74
160	37	46	43	54	65	73	58	48	75
170	37	47	43	54	65	74	58	49	75
190	38	47	44	55	66	74	59	49	76

Notes: Sound Pressure per ARI Standard 575 free field. Sound pressure levels taken at a distance of one meter and 1.5 meter height.

Table 32, WGS Sound Pressure with Sound Insulation

WGS Unit Size	Octave Band Sound Power Levels Per ARI Standard 575 (dB)								Overall "A" Weighted
	62 Hz	125 Hz	250 Hz	500 Hz	1000 Hz	2000 Hz	4000 Hz	8000 Hz	
130	36	44	42	51	59	67	55	43	68
140	36	45	42	52	59	67	55	44	69
160	37	45	43	52	60	68	56	44	69
170	37	46	43	53	60	68	56	45	70
190	38	46	44	53	61	69	57	45	70

Notes: Sound Pressure per ARI Standard 575 free field. Sound pressure levels taken at a distance of one meter and 1.5 meter height.

Figure 15, Sound Enclosure



Sound Reduction

The sound enclosure is constructed of pre-painted steel formed into panels, gasketed and lined with an aluminized polyester-faced sound absorbing insulation for maximum sound attenuation. The combination of the metal panels and the specialized sound foam, provide an excellent sound damping effect. The enclosure can be factory or field installed and is completely removable. No field alterations are required to install the enclosure. Access to the compressors is gained by removing any of the panels that are fastened with bolts not screws, facilitating service access and proper reinstallation of panels. Heat is allowed to escape through strategically placed air gaps in the enclosure to help prevent compressor overheating. The reduction in sound level is shown in the tables on page 44.

The enclosure increases the

length, width, height and weight of the unit.

Application Data

Location and Space Requirements

The units are designed for indoor application and must be located in a space where the temperature is 40°F (4.4°C) or above. Provide clearance of 3 ft. (914 mm) on each side and end for piping and to provide space for servicing the unit. Consult the National Electric Code (NEC) and local codes as they may require additional clearance in front of the control/power panel.

Provide clearance at either end of the unit to permit cleaning or removal of condenser tubes (see dimensional data). If a door or window is provided at one end of the unit, the tubes can be replaced through the opening provided.

Foundation

Mount the unit on a level concrete foundation. Floors must be strong enough to support the unit operating weight. If necessary, use structural supports to transfer the weight of the unit to the nearest beams.

Vibration Isolation

Vibration mounts are recommended for upper floor installations or where compressor noises might be objectionable (next to occupied spaces such as offices, meeting rooms, etc.).

Vibration eliminators can be used for water piping connected to the unit to minimize transmission of water or pump noise into occupied spaces.

System Water Volume

All chilled water systems need adequate time to recognize a load change, respond to that load change and stabilize, without undesirable short cycling of the compressors or loss of control. In air conditioning systems, the potential for short cycling usually exists when the building load falls below the minimum chiller plant capacity or on close-coupled systems with very small water volumes.

Some of the things the designer should consider when looking at water volume are the minimum cooling load, the minimum chiller plant capacity during the low load period and the desired cycle time for the compressors.

Assuming that there are no sudden load changes and that the chiller plant has reasonable turndown, a rule of thumb of “gallons of water volume equal to two to three times the chilled water gpm flow rate” is often used.

A properly designed storage tank should be added if the system components do not provide sufficient water volume.

Evaporator Variable Flow

Reducing evaporator flow in proportion to load can reduce system power consumption. Certain restrictions apply to the amount and rate of flow change. The rate of flow change should be a maximum of 10 percent of the change per minute. Do not reduce flow lower than the minimum flows listed on the evaporator pressure drop page.

Chilled Water Piping

Flush the system water piping thoroughly before making connections to the unit evaporator. Install a 20-mesh strainer in the return water line before the inlet to the chiller. Design the water piping so the chilled water circulating pump discharges into the evaporator inlet.

Install a flow switch in the horizontal piping of the supply (evaporator outlet) water line.

Provide drain connections at low points in the system to permit complete drainage. Locate air vents at the high points in the system to purge air out. Purge air from the water system before unit start-up to help ensure adequate flow through the evaporator.

Install pressure gauges in the inlet and outlet water lines to the evaporator. Measure pressure drop through the evaporator to calculate proper flow. Vibration eliminators are recommended in both the supply and return water lines.

Insulate chilled water piping to reduce heat loss and prevent condensation.

Figure 16, Typical Chilled Water Piping

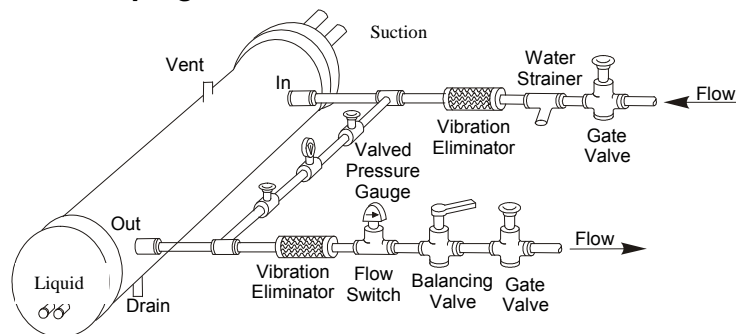

Condenser Water (AW Units)

Arrange the condenser water so the water enters the two bottom condenser piping connections, or the single bottom manifold connection, if the optional manifold has been ordered. The condenser water will discharge from the top condenser connections or the single top connection of the optional manifold. Failing to arrange the condenser water as stated above will negatively affect the capacity and efficiency.

Install pressure gauges in the inlet and outlet water lines to the condenser. Measure the pressure drop through the condenser to determine flow using the pressure drop/flow curves on page 27. Vibration eliminators are recommended in both the supply and return water lines.

Install 20-mesh strainers and isolation valves as shown above.

Water-cooled condensers can be piped for use with cooling towers or well water. Consider freeze protection and scaling problems on cooling tower applications. Contact the cooling tower manufacturer for equipment characteristics and limitations for the specific application.

Head pressure control must be provided if the entering condenser water can fall below 65°F. The MicroTech II unit controller can provide this function, using entering condenser water as the control point. The control will work with or without the optional condenser manifolds. The water sensors are factory-installed. The controller setpoints have to be adjusted for water control and certain output wiring connections made to the tower components.

Ice Storage Applications

The MicroTech II controller has logic to change setpoints from the low temperature ice-making mode to higher, normal comfort cooling setpoints. It is important that the MicroTech II controller receive a 0 VAC (normal operation) to 24 VAC (ice mode) signal to convert from ice mode to normal operating mode. The MicroTech II controller includes logic to keep the compressors fully loaded when operating below 30°F (-1.1°C). The double insulation thickness option is recommended to prevent sweating.

Two Pipe Systems

When the same two pipes are used for both heating and cooling water, several limitations should be observed. The maximum allowable temperature entering the evaporator in a non-operating mode is 100°F. For unit operation and system changeover from heating to cooling, the maximum allowable temperature entering the evaporator is 90°F. System controls provided by others must prevent chiller operation until the loop temperature drops to 90°F.

Electrical Connection

Every WGS chiller requires field installation of the main supply power plus mandatory flow switch interlock and optional pump starter auxiliary contact interlock. A control circuit transformer installed at the factory eliminates the need for field installation of a separate 115V supply to the control circuit. A separate 115V field connection to the control circuit can be substituted. A system time clock and remote on-off switch can also be field installed.

See Figure 10 or Figure 11 on pages 37 and 38 for field electrical hookups (water-cooled or remote condenser respectively). Each unit is provided with its specific wiring diagram in the control panel. All wiring must be done according to local and national codes.

Main Power Supply Disconnect Switch

Every WGS unit with the standard multi-point power supply is equipped with power blocks and no compressor circuit breakers. Single-point power connection is available as an option using one power block and individual compressor circuit breakers.

A factory-installed non-fused disconnect switch with a through-the-door handle (required to meet NEC Code for disconnects) is available as an option with single- or multiple-point power supply. The single-point disconnect includes individual compressor circuit breakers. The disconnect switch(s) is properly sized for the model and voltage supplied.

A field-supplied and installed remote disconnect switch can also be used.

Control Circuit

A control power transformer is standard equipment on WGS units. Terminals are provided in the unit control center (terminals TB1 and TB1-2) for field connection to a remote 115V power supply if desired.

Terminals are also provided for field connection of the chilled water flow switch, unit time clock, ambient thermostat and/or remote on/off switch.

Condenser Pump Interlock

The condenser water pump should be interlocked to cycle with the compressor(s). This will prevent the refrigerant pressure from being overly depressed during the off cycle and allows the energy savings of pump shutdown. Interlock terminals are provided in the unit control panel.

Application Limitations

1. Maximum allowable condenser water pressure is 225 psig (1551 kPa).
2. Maximum allowable evaporator water pressure is 150 psig (1034 kPa).
3. Maximum design saturated discharge temperature (SDT) is 155°F (68°C). $SDT = \text{Condensing temperature} + \text{discharge line loss}$.
4. Maximum allowable water temperature to evaporator when not operating is 100°F (37.8°C). Maximum entering water temperature for operating cycle is 90°F (32.2°C) (during system changeover from heating to cooling cycle).
5. Minimum design leaving water temperature from the evaporator without anti-freeze protection is 40°F (4.4°C).

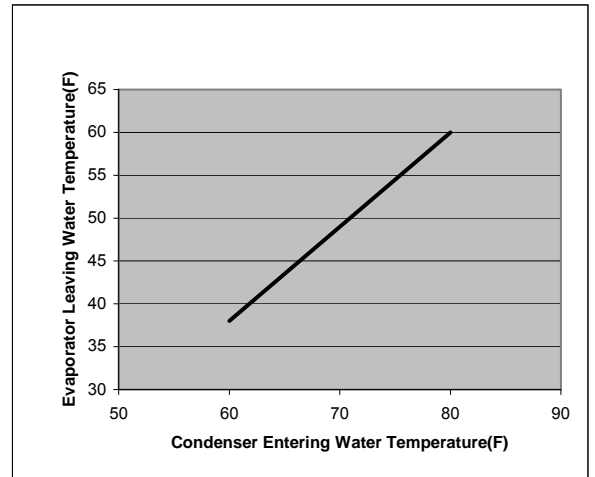

6. Minimum condenser water entering temperature per chart above.

Remote Condenser Refrigerant Piping

Careful design of refrigerant piping is necessary for proper system operation. Design the refrigerant piping to accomplish the following:

1. Assure proper refrigerant feed to the evaporator.
2. Provide practical and economical refrigerant line sizes without excess pressure drop.
3. Maintain uniform oil return to the compressor under all load conditions.
4. Refer to the latest version of the ASHRAE Handbook for recommended piping practice.

⚠ IMPORTANT NOTE ⚠

This form, Service Form SF99006, and an isometric sketch of the Remote Piping Layout showing pipe size, location of fittings, measured lengths, and elevations **MUST BE SUBMITTED TO McQuay Technical Response Center and reviewed at least two weeks prior to beginning piping installation. McQuay Factory Service will not perform startup without reviewed Service Form SF99006 and drawing. Installation must match reviewed drawing. All field piping, wiring and procedures must comply with design guidelines set forth in the Remote Evaporator section of product literature, and be performed in accordance with ASHRAE, EPA, local codes and industry standards. Any product failure caused or contributed to by failure to comply with appropriate design guidelines will not be covered by manufacturer's warranty. McQuay Technical Response: Fax: 763-509-7666; Phone : 540-248-9201; E-mail: techresponse@mcquay.com**

NOTE: The following applies to all size units:

- Maximum linear line length shall not exceed 75 feet
- Maximum Total Equivalent Length (TEL) shall not exceed 180 feet
- The condenser shall not be located more than 15 feet above the indoor unit
- The condenser shall not be located more than 20 feet below the indoor unit
- No underground piping
- Must have adequate service taps for operation evaluation

Limit the length of refrigerant piping by locating the condenser as close to the chiller as possible. Avoid all unnecessary changes in direction or elevation. The condensers must be selected with separate condenser sections for each of the chiller's two circuits. The circuits must not be combined, and precautions must be taken during installation to avoid cross-connecting the circuits. Do not run refrigerant piping underground.

Liquid Line

Where there is a vertical *lift* from the condenser to the chiller, adequate subcooling must be provided to prevent liquid flashing before the expansion valve. Install a shutoff valve in the liquid line to allow isolation of the remote condenser.

Discharge line

The discharge line should be trapped at the compressor and looped at the condenser (inverted trap) to prevent liquid refrigerant from draining back to the compressor (See Figure 17). Pressure drop should be held at a minimum. Transitions in discharge line sizing must be done in a manner that does not impede oil return.

Line length

Maximum linear feet of piping is 75 feet. Maximum TEL (total equivalent feet) is 180 feet.

Table 33, Recommended Refrigerant Pipe Sizes

1. Pressure drop is in equivalent degrees F.

Horizontal or Downflow Discharge Line Sizes

Unit, Circuit	Nominal Circuit Tons	Conn. Size At Unit		Recommended Discharge Line Size, inch, O.D.				
				Up to 50 Equiv.Ft	Up to 75 Equiv.Ft	Up to 100 Equiv.Ft.	Up to 125 Equiv.Ft.	Up to 150 Equiv.Ft.
WGS 130, Both WGS 140, Cir #1	65	2 5/8	Line Size Press Drop, °F	2 5/8 0.55	2 5/8 0.82	2 5/8 1.10	2 5/8 1.37	2 5/8 1.64
WGS 140, Cir #2 WGS 160, Both WGS 170, Cir #1	80	2 5/8	Line Size Press Drop, ° F	2 5/8 0.80	2 5/8 1.21	2 5/8 1.61	2 5/8 2.01	3 1/8 1.04
WGS 170, Cir #2 WGS 190, Both	95	2 5/8	Line Size Press Drop, ° F	2 5/8 1.08	2 5/8 1.62	2 5/8 2.16	3 1/8 1.17	3 1/8 1.40

Recommended Vertical Upflow Discharge Line Sizes

Unit, Circuit	Nominal Circuit Tons	Connection Size, O.D. at WGS Unit		Recommended Discharge Line Size, inch, O.D.		
				Up to 50 Equiv.Ft	Up to 75 Equiv.Ft	Up to 100 Equiv.Ft.
WGS 130, Both WGS 140, Cir #1	65	2 5/8	Line Size Press Drop – ° F	2 1/8 1.52	2 1/8 2.28	2 1/8 3.03
WGS 140, Cir #2 WGS 160, Both WGS 170, Cir #1	80	2 5/8	Line Size Press Drop – °F	2 5/8 0.80	2 5/8 0.99	2 5/8 1.32
WGS 170, Cir #2 WGS 190, Both	95	2 5/8	Line Size Press Drop – °F	2 5/8 0.94	2 5/8 1.41	2 5/8 1.88

Recommended Liquid Line Size

Unit, Circuit	Nominal Circuit Tons	Conn. Size, at Unit		Recommended Liquid Line Size, inch O.D.				
				Up to 50 Equiv.Ft	Up to 75 Equiv.Ft	Up to 100 Equiv.Ft.	Up to 125 Equiv.Ft.	Up to 150 Equiv.Ft.
WGS 130, Both WGS 140, Cir #1	65	1 3/8	Line Size Press Drop – F	1 3/8 0.76	1 3/8 1.14	1 3/8 1.52	1 3/8 1.89	1 3/8 2.27
WGS 140, Cir #2 WGS 160, Both WGS 170, Cir #1 WGS 170, Cir #2 WGS190, Both	80	1 3/8	Line Size Press Drop – F	1 3/8 1.11	1 3/8 1.67	1 3/8 2.23	1 3/8 2.78	1 3/8 3.34

Relief Valves

All relief valves (including the oil sump) must be piped to the outside of the building in accordance with ANSI/ASHRAE 15-2001. The 2001 standard has revised the calculation method compared to previous issues.

Table 34, Relief Valve Capacities

COMPONENT	CAPACITY lbs of AIR/ min	PRESSURE psig
Oil Separator	54	350
Suction line	17.3	200
Condenser	54	350

Figure 17, Condenser Above Compressor (One of Two Circuits Shown)

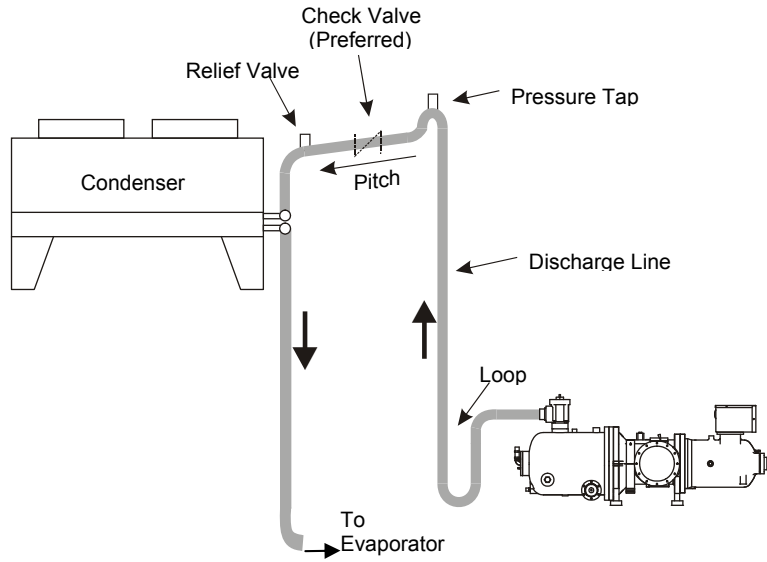

- Maximum linear line length shall not exceed 75 ft.
- Maximum Total Equivalent Length (TEL) shall not exceed 180 ft.
- The condenser shall not be located more than 15 ft above the indoor unit.
- The condenser shall not be located more than 20 ft below the indoor unit.

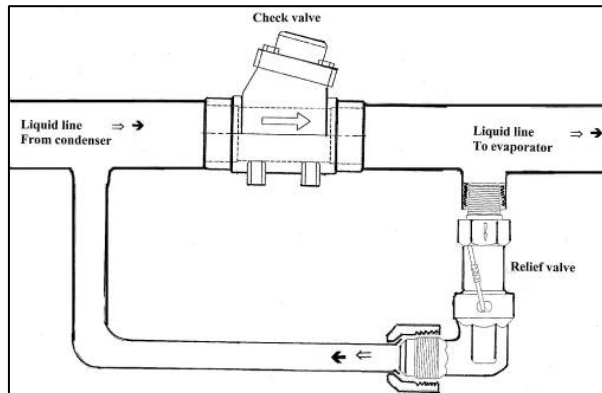

Optional Features

Controls/Instrumentation

Water Flow Switch

A field-installed and wired flow switch in the chilled water, or both chilled water and condenser water, piping to help prevent evaporator freeze-up under low- or no-flow conditions. Terminals are provided in the unit control center for field hookup of the water flow switch(s). Installation of a chilled water flow switch is mandatory.

Water Flow Switch (Factory-Installed, Solid State)

A solid state flow switch located in the evaporator outlet nozzle is factory installed and wired. In addition to the electronic output signal, the switch has an LED display to visually indicate the presence of flow. It eliminates the need for a field-installed switch.

The 24 Vac powered flow sensor is a solid state alternative to mechanical switches for sensing the acceptable flow rate of water. These compact units are constructed of corrosion-resistant materials and 316 stainless steel parts and installed directly through a ¼ inch NPT into the flow.

The flow sensors operate on the calorimetric principle. The sensors use the cooling effect of a flowing fluid to provide reliable flow rate detection of liquids over a very wide flow range. The amount of thermal energy that is removed from the tip determines the local flow rate and when it exceeds a setpoint it changes the output-state.

BAS Interface

McQuay's Open Choices™ feature consists of a factory-installed communication module for LONMARK®, Modbus®, or BACnet® with RS-485 port and Ethernet, standard protocols.

Remote Communication Module

A remote interface panel, field wired from the chiller controller to the remote pane to provide remote viewing of unit operation, clearing of alarms and changing of setpoints. See page 9 for details

Electrical

Power Connection Options

The standard connection is multi-point power connections (two) to power blocks with no disconnect switches or circuit breakers. A compressor isolation circuit breaker for each circuit is not available on multi-point arrangements and is included on all single point arrangements. There are seven options as shown below and summarized in Table 35 on page 53. Interrupt ratings are summarized in Table 36.

Disconnect Switches, Multi-Point

A non-fused disconnect switch for each circuit (two), with through-the-door handle. The disconnect switches are properly sized for model and voltage required. No compressor isolation circuit breakers are included.

High Interrupt Disconnect Switches, Multi-Point

A high interrupt current rating, non-fused disconnect switch for each circuit (two), with through-the-door handle. The disconnect switches are properly sized for model and voltage required. No compressor isolation circuit breakers are included.

High Short Circuit Current Rated Panel, Multi-Point

A high short circuit rated panel with high interrupt current rated disconnect switches for each circuit, properly sized for model and voltage required. The high short circuit rated panel means that a short circuit current up to the ratings shown in Table 36 will be contained in the panel. There is a short period of time when the circuit breaker will pass a short circuit before opening a circuit that can damage downstream components. In other words, the enclosure is stronger than a standard enclosure. No compressor isolation circuit breakers are included.

Power Block, Single Point

Connection to a single power block with compressor isolation circuit breakers for each circuit. The circuit breakers are only accessible when the panel door is opened. No disconnect switches.

Disconnect Switch, Single Point

Connection to a single disconnect switch with compressor isolation circuit breakers for each circuit. The circuit breakers are only accessible when the panel door is opened.

High Interrupt Disconnect Switch, Single Point

A high interrupt current rating, non-fused disconnect switch with through-the-door handle. The disconnect switch is properly sized for model and voltage required. Compressor isolation circuit breakers for each circuit are included. The circuit breakers are only accessible when the panel door is opened.

High Short Circuit Current Rated Panel, Single Point

A high short circuit rated panel with a single disconnect switch, properly sized for model and voltage required. The high short circuit rated panel means that a short circuit current up to the ratings shown in Table 36 will be contained in the panel. There is a short period of time when the circuit breaker will pass a short circuit before opening a circuit that can damage downstream components. In other words, the enclosure is stronger than a standard enclosure. Compressor isolation circuit breakers for each circuit are included. . The circuit breakers are only accessible when the panel door is opened.

Table 35, Power Connection Options

	Multi-Point (Code)	Single Point (Code)	
Power Block	STD (MN)	OPT. Incl CB (PC)	Select Only One of These Options
Disconnect Switch(s)	OPT, No CB (WN)	OPT, Incl CB (DC)	
High Interrupt Disconnect Switch.	OPT, No CB (WT)	OPT, Incl CB (DT)	
High Short Circuit Rated Panel	OPT, No CB (WH)	OPT, Incl CB (DH)	

NOTE:

1. CB = Compressor isolation circuit breaker
2. (Code) is the McQuay ordering code

Table 36, Interrupt Ratings (KA)

	208V	230V	380V	460V	600V
Standard Short Circuit Rating	35	35	35	35	10
High Interrupt Rating Disconnect Switch (1)	200	200	100	100	25
High Short Circuit Rating Panel (2)	65	65	65	65	25

NOTES:

1. High Interrupt Rating Disconnect Switch is for only the disconnect switch.
2. High Short Circuit Rating (HSCCR) Panel includes high interrupt rating disconnect switch(es).

115-Volt Convenience Outlet

Provides a 115-volt power source on the unit for service equipment.

Unit

Suction Shut-Off Valves

A suction shut-off valve located in the suction line of each circuit. Used in conjunction with the standard discharge valve to isolate the compressor.

Vibration Isolators

Spring or rubber-in-shear vibration isolators are available as a kit for field installation to reduce vibration transmission through the unit base.

Compressor Sound Enclosure

Factory-installed acoustical enclosure is available for all units when lower sound levels are required. The enclosure can be factory or field installed.

Evaporator Connections

Left-hand evaporator water connections (as viewed looking at the control panel) are optional. Right-hand are standard.

Double Insulation

The evaporator is available with an additional layer of 3/4-inch insulation. This option is recommended for ice or low temperature applications.

Condenser Water Manifolds

The two condenser inlets are factory-piped to a common connection. The two condenser outlets are factory-piped to a common connection. This option provides one inlet and one outlet condenser water connection.

Shipping Skid

A wood shipping skid is available to aid in moving the unit.

Product Specifications

Water-Cooled Screw Compressor Chiller

WGS 130AW through WGS 190AW

PART 1 - GENERAL

1.01 SUMMARY

Section includes design, performance criteria, refrigerants, controls, and installation requirements for water-cooled screw compressor packaged chillers.

1.02 REFERENCES

Comply with applicable Standards/Codes of ARI 550/590-98, ANSI/ASHRAE 15, ASME Section VIII, NEC, and OSHA as adopted by the State.

Equipment shall meet efficiency standards of ASHRAE Standard 90.1 for October 2001.

1.03 SUBMITTALS

A. Submit shop drawings and product data in accordance with contract specifications.

B. Submittals shall include the following:

1. Dimensioned plan and elevation view drawings, required clearances, and location of all field connections.
2. Summary of all auxiliary utility requirements such as: electricity, water, compressed air, etc. Summary shall indicate quality and quantity of each required utility.
3. Single-line schematic drawing of the field power hookup requirements, indicating all items that are furnished.
4. Schematic diagram of control system indicating points for field connection. Diagram shall fully delineate field and factory wiring.
5. Installation manual.

1.04 QUALITY ASSURANCE

A. Qualifications: Equipment manufacturer must specialize in the manufacture of the products specified and have five years experience with similar equipment and the refrigerant offered.

B. Regulatory Requirements: Comply with the codes and standards specified.

C. The chiller manufacturing facility must be ISO certified.

1.05 DELIVERY AND HANDLING

A. Chillers shall be delivered to the job site completely assembled and charged with refrigerant and oil by the manufacturer.

B. Comply with the manufacturer's instructions for rigging and handling equipment.

1.06 WARRANTY

The equipment manufacturer's warranty shall be for a period of one year from date of equipment start-up but not more than 18 months from shipment. The warranty shall cover defective material and workmanship within the above period, excluding refrigerant.

OR

The equipment manufacturer's warranty shall be for a period of two years from date of equipment start-up but not more than 30 months from shipment. The warranty shall cover defective material and workmanship within the above period, excluding refrigerant.

OR

The equipment manufacturer's warranty shall be for a period of five years from date of equipment start-up but not more than 66 months from shipment. The warranty shall cover defective material and workmanship within the above period, excluding refrigerant.

PART 2--PRODUCTS

2.01 ACCEPTABLE MANUFACTURERS

- A. Basis of Design - McQuay model WGS, including the standard product features and all special features required per the plans and specifications.
- B. Equal Products - Equipment manufactured by [ENTER MANUFACTURER NAME HERE] may be acceptable as an equal. Naming these products as equal does not imply that their standard construction or configuration is acceptable or meets the specifications. Equipment proposed "as equal", must meet the specifications including all architectural, mechanical, electrical, and structural details, all scheduled performance and the job design, plans and specifications.

2.02 UNIT DESCRIPTION

Provide and install as shown on the plans, factory assembled, factory charged, and factory run-tested water-cooled screw compressor packaged chillers in the quantity and size specified. Each chiller shall consist of two semi-hermetic, rotary screw compressors; a two-circuit shell-and-tube evaporator; two shell-and-tube water-cooled condensers, control system and all components necessary for controlled unit operation. Chillers using zeotropic refrigerants such as HFC-407C shall have a five-year refrigerant warranty.

2.03 DESIGN REQUIREMENTS

- A. General: Provide a complete screw compressor packaged chiller as specified herein and as shown on the drawings. The unit(s) shall be in accordance with the standards referenced in section 1.02 and any local codes in effect.
- B. Performance: Refer to the schedule of performance on the drawings. Performance shall be in accordance with applicable ARI Standard.
- C. Acoustics: Sound for the unit shall not exceed the following tabulated levels. When needed to achieve these levels, the manufacturer shall provide the necessary sound treatment. Acceptable sound attenuation devices include, but are not limited to compressor sound blankets, low-sound fans and discharge gas mufflers. Chiller performance, affected by the use of these devices, shall meet or exceed the scheduled performance requirements. Sound data shall be in one-third octave bands and be provided with the quotation. Sound measurements are to be taken in accordance with ARI Standard 575. [ENTER BELOW - TABLE OF OCTAVE BAND CENTER FREQUENCIES AND OVERALL "A"]

2.04 CHILLER COMPONENTS

- A. Compressors: The compressors shall be semi-hermetic, single rotor, rotary screw type with internal oil separator. The compressor motor shall be refrigerant gas cooled, high torque, induction type, two-pole, with inherent thermal

protection on all three phases and shall be mounted on RIS vibration isolator pads.

- B. Electric Motors: Compressor motors shall be high torque, two pole, semi-hermetic, squirrel cage induction type with inherent thermal protection on all three phases and cooled by suction gas. Full-load power factor shall be, at minimum, 0.90. Motors not meeting this minimum power factor must be capacitor-corrected to 0.90 or better.
- C. Solid-State Motor Starters (each compressor): Starter shall be designed using the current generation of reliable solid-state technology. Each starter shall provide controlled motor acceleration and deceleration, and shall provide protection for the following conditions: ground fault, phase rotation, electronic thermal overload, over/under current, stalled motor, single phase, high load current and current unbalance. Across-the-line or wye-delta starters are not acceptable. Acceptable solid-state starter manufacturers are GE, Cutler-Hammer, Benshaw or Reliance. The solid state starters shall be capable of self-diagnostics, metering, and have an LED display to include the following operating and fault messages:

Operating Messages:

- Line voltage not present
- Voltage present, starter ready
- Motor accelerating
- Motor at full speed
- Motor at full speed, ramp time expired
- Stop command received, motor decelerating
- Thermal overload has reached 90% to 99%
- Thermal overload at 100%, motor stopped
- Thermal overload reduced to 60%, motor can restart
- Passcode enabled
- Passcode disabled
- Thermal overload content in percentage

Fault Messages:

- System power not three phase
- Phase sequence incorrect
- Line frequency less than 25 Hz
- Line frequency more than 72 Hz
- Excessive current unbalance
- Operating parameters lost
- No current after "Run" command
- Undercurrent trip occurred
- Overcurrent trip occurred
- Control power too low
- Motor stalled during acceleration
- External fault

- D. Evaporator: The evaporator shall be two circuit, direct expansion, shell-and-tube type with copper tubes rolled into steel tube sheets. It shall be insulated with 3/4 inch (19 mm) closed cell polyurethane insulation and designed for 150 psi (1034 kPa) water side working pressure and 354 psi (2441 kPa) refrigerant side pressure. It shall be designed in accordance with ASME Pressure Vessel Code, Section VIII,

and have ANSI B9.1 pressure relief valves.

OPTION: The evaporator shall have 1 1/2 inch (40 mm) closed cell polyurethane insulation in lieu of standard 3/4 inch (19 mm).

OPTION: The evaporator shall have left-hand water connection when viewed from the control panel.

- E. Condensers: Horizontal shell and finned tube type with steel shell and integral finned copper tubes rolled into steel tube sheets. The condenser shall be equipped with intermediate tube supports and construct in accordance with the requirements of ASME Unfired Pressure Vessel Code Section VIII and ANSI B9.1 Safety Code. It shall be designed for 225 psi (1551 kPa) water side working pressure and 350 psi (2413 kPa) refrigerant side pressure. It shall have ANSI B9.1 pressure relief valves..
- F. Refrigerant Circuit: The unit shall have two or more refrigerant circuits, completely independent of each other. Each circuit shall be equipped with one compressor with integral oil separator, one microprocessor controller, a factory-mounted control circuit transformer, electronic expansion valve, compressor suction shutoff valve, discharge check valve, liquid line shutoff valves, replaceable core filter-dryers, sight-glass with moisture indicator. Each circuit shall be capable of operating independently, not being disabled in the event of fault(s) on the other circuit(s).
OPTION: Each compressor shall have a suction service shutoff valve.
- G. Electric Panel: The electric panel shall consist of two separated compartments, one for power components and one for control components. The control section shall contain a microprocessor controller for each circuit and one for the unit, providing operating and equipment protection controls. The circuit controllers shall operate independently of each other.
OPTION: The panel shall include a 115-volt convenience outlet.

The power section shall include solid state motor starters, a control transformer with primary and secondary fusing, microprocessor transformers with fusing, standard power blocks for each electrical circuit power connection, and switches for each circuit pumpdown and unit control power. The control panel shall have a hinged, tool-locked door.

OPTION: The unit shall have power connection to factory-installed, non-fused disconnect switches with through-the-door handles for each electric circuit.

OPTION: The unit shall have power connection to factory-installed, high interrupt current rated, non-fused disconnect switches with through-the-door handles for each electric circuit.

OPTION: The unit shall have a high short circuit rated panel with high interrupt current rated, non-fused disconnect switches with through-the-door handles for each electric circuit.

OPTION: The unit shall have single point power connection to a factory-installed power block that is factory-wired to compressor isolation circuit breakers for each circuit.

OPTION: The unit shall have single point power connection to a factory-installed, non-fused disconnect switch with through-the-door handle. Each circuit shall be equipped with factory installed compressor isolation circuit breakers.

OPTION: The unit shall have single point power connection to a factory-installed, high interrupt current rated, non-fused disconnect switch with through-the-door handle. Each circuit shall be equipped with factory-installed compressor isolation circuit breakers.

OPTION: The unit shall have a high short circuit rated panel with single point power connection to a factory-installed, high interrupt current rated, non-fused

disconnect switch with through-the-door handle. Each circuit shall be equipped with a factory-installed compressor isolation circuit breaker.

The control system shall stage and load the compressors based on the leaving water temperature. Equipment protection devices controlled by the microprocessor shall include motor protection, high pressure, loss of refrigerant, loss of water flow, freeze protection, and low refrigerant pressure. Controls shall include auto/stop switch, chilled water setpoint adjustment, anti-recycle timer, and digital display with water temperature and setpoint, operating temperatures and pressures, and diagnostic messages. The following features and functions shall be included:

1. The control logic shall be designed to maximize operating efficiency and equipment life with protections for operation under unusual conditions. The system shall intelligently stage the unit to sustain leaving water temperature precision and stability while minimizing compressor cycling.
 2. The following features and functions shall be included:
 - a. Password protection for setpoint adjustment.
 - b. Durable liquid crystal display (LCD) screen type, having minimum four 20-character lines with 6 key input pad conveniently mounted on the unit controller. Default language and units of measure shall be English and I-P respectively. Messages shall be in plain English. Coded messages, LED indicators and LED displays are not acceptable.
 - c. Remote reset of chilled water temperature using a 4-20mA signal.
 - d. Soft-load operation, protecting the compressor by preventing full-load operation during the initial chilled fluid pull-down period.
 - e. BAS communication through Open Choices™. Optional modular plug-ins that enable the unit controller to communicate using standardized protocols such as LONTALK®, Modbus® and BACnet® without a separate gateway.
 - f. Non-volatile program memory allowing auto-restart after a power failure without requiring a UPS (un-interruptible power supply).
 - g. Recording of safety shutdowns, including date-and-time stamp with system temperatures and pressures. A minimum of six previous occurrences shall be maintained in a revolving memory.
 - h. Start-to-start and stop-to-start cycle timers, providing minimum compressor off-time while maximizing motor protection.
 - i. Lead-lag compressor staging for part-load operation by manual selection or automatically by circuit run hours.
 - j. Pro-active compressor unloading when selected operating parameters exceed design settings, such as high discharge pressure or low evaporator pressure.
 - k. Diagnostic monitoring of unit operation, providing a pre-alarm signal in advance of a potential shutdown, allowing time for corrective action.
- H. The following options are to be included:
- Chilled water flow switch to be field mounted in the chilled water line and field wired to terminals in the control panel.
 - Rubber-In-Shear **OR** spring vibration isolators for field installation per plans.
 - Compressor acoustical enclosure for sound reduction.

PART 3 - EXECUTION

3.01 INSTALLATION

- A. Install in strict accordance with manufacturer's requirements, shop drawings, and contract documents.
- B. Adjust and level chiller in alignment on supports.
- C. Coordinate electrical installation with electrical contractor.
- D. Coordinate controls with control contractor.
- E. Provide all appurtenances required to ensure a fully operational and functional chiller.

3.02 START-UP

- A. Ensure proper charge of refrigerant and oil.
- B. Provide testing, and starting of machine, and instruction to the Owner in its proper operation and maintenance.

Screw Compressor Chiller with Remote Condenser

WGS 130AA to 190AA

PART 1 - GENERAL

1.01 SUMMARY

Section includes design, performance criteria, refrigerants, controls, and installation requirements for screw compressor packaged chillers with remote condensers.

1.02 REFERENCES

Comply with applicable Standards/Codes of ARI 550/590-98, ANSI/ASHRAE 15, ASME Section VIII, NEC, and OSHA as adopted by the State.

Equipment shall meet efficiency standards of ASHRAE Standard 90.1 for October 2001.

1.03 SUBMITTALS

A. Submit shop drawings and product data in accordance with contract specifications.

B. Submittals shall include the following:

1. Dimensioned plan and elevation view drawings, required clearances, and location of all field connections including field installed refrigerant piping.
2. Summary of all auxiliary utility requirements such as: electricity, water, compressed air, etc. Summary shall indicate quality and quantity of each required utility.
3. Single-line schematic drawing of the power field hookup requirements, indicating all items that are furnished.
4. Schematic diagram of control system indicating points for field connection. Diagram shall fully delineate field and factory wiring.
5. Installation manual.

1.04 QUALITY ASSURANCE

A. Qualifications: Equipment manufacturer must specialize in the manufacture of the products specified and have five years experience with similar equipment and the refrigerant offered.

B. Regulatory Requirements: Comply with the codes and standards specified.

C. The chiller manufacturer's facility must be ISO certified.

1.05 DELIVERY AND HANDLING

A. Chillers, less remote condensers, shall be delivered to the job site completely assembled (less condenser) and charged with refrigerant and oil by the manufacturer.

B. Comply with the manufacturer's instructions for rigging and handling equipment.

1.06 WARRANTY

The equipment manufacturer's warranty shall be for a period of one year from date of equipment start-up but not more than 18 months from shipment. The warranty shall cover defective material and workmanship within the above period, excluding refrigerant.

OR

The equipment manufacturer's warranty shall be for a period of two years from date of equipment start-up but not more than 30 months from shipment. The warranty shall cover defective material and workmanship within the above period, excluding refrigerant.

OR

The equipment manufacturer's warranty shall be for a period of five years from date of equipment start-up but not more than 66 months from shipment. The warranty shall cover defective material and workmanship within the above period, excluding refrigerant.

PART 2--PRODUCTS

2.01 ACCEPTABLE MANUFACTURERS

- A. Basis of Design - McQuay model WGS, including the standard product features and all special features required per the plans and specifications.
- B. Equal Products - Equipment manufactured by [ENTER MANUFACTURER NAME HERE] may be acceptable as an equal. Naming these products as equal does not imply that their standard construction or configuration is acceptable or meets the specifications. Equipment proposed "as equal", must meet the specifications including all architectural, mechanical, electrical, and structural details, all scheduled performance and the job design, plans and specifications.

2.02 UNIT DESCRIPTION

Provide and install as shown on the plans, factory assembled, factory charged, and factory run-tested screw compressor chillers in the quantity and size specified. Each chiller system shall consist of an indoor unit with two semi-hermetic rotary screw compressors, two-circuit shell-and-tube evaporator, control system and all components necessary for controlled unit operation. The remote condenser shall be field piped to the indoor unit. The contractor shall provide sufficient refrigerant to charge the field piping and condenser. Chillers using zeotropic refrigerants such as HFC-407C shall have a five-year refrigerant warranty.

2.03 DESIGN REQUIREMENTS

- A. General: Provide a complete screw compressor packaged chiller as specified herein and as shown on the drawings. The unit(s) shall be in accordance with the standards referenced in section 1.02 and any local codes.
- B. Performance: Refer to the schedule of performance on the drawings. Performance shall be in accordance with applicable ARI Standard.
- C. Acoustics: Sound for the unit shall not exceed the following tabulated levels. When needed to achieve these levels, the manufacturer shall provide the necessary sound treatment. Acceptable sound attenuation devices include, but are not limited to compressor sound blankets, low-sound fans and discharge gas mufflers. Chiller performance, affected by the use of these devices, shall meet or exceed the scheduled performance requirements. Sound data shall be in one-third octave bands and be provided with the quotation. Sound measurements are to be taken in accordance with ARI Standard 575. [ENTER BELOW - TABLE OF OCTAVE BAND CENTER FREQUENCIES AND OVERALL "A"]

2.04 CHILLER COMPONENTS

- A. Compressors: The compressors shall be semi-hermetic, single rotor, rotary screw type with internal oil separator. The compressor motor shall be refrigerant gas cooled, high torque, induction type, two-pole, with inherent thermal protection on all three phases and shall be mounted on RIS vibration isolator pads.
- B. Electric motors: Compressor motors shall be high torque, two pole, semi-hermetic, squirrel cage induction type with inherent thermal protection on all three phases and cooled by suction gas. Full-load power factor shall be, at minimum, 0.90. Motors not meeting this minimum power factor must be capacitor-corrected to 0.90 or better.
- C. Solid-State Motor Starters (for each compressor): Starter shall be designed using the current generation of reliable solid-state technology. Each starter shall provide controlled motor acceleration and deceleration, and shall extend protections covering the following conditions: phase rotation, electronic thermal overload, over/under current, stalled motor, single phase, high load current and current unbalance. Across-the-line or wye-delta starters are not acceptable. Acceptable solid-state starter manufacturers are GE, Cutler-Hammer, Benshaw or Reliance. The solid state starters shall be capable of self-diagnostics, metering, and have an LED display to include the following operating and fault messages:

Operating Messages:

- Line voltage not present
- Voltage present, starter ready
- Motor accelerating
- Motor at full speed
- Motor at full speed, ramp time expired
- Stop command received, motor decelerating
- Thermal overload has reached 90% to 99%
- Thermal overload at 100%, motor stopped
- Thermal overload reduced to 60%, motor can restart
- Passcode enabled
- Passcode disabled
- Thermal overload content in percentage

Fault Messages:

- System power not three phase
- Phase sequence incorrect
- Line frequency less than 25 Hz
- Line frequency more than 72 Hz
- Excessive current unbalance
- Operating parameters lost
- No current after "Run" command
- Undercurrent trip occurred
- Overcurrent trip occurred
- Control power too low
- Motor stalled during acceleration
- External fault

- D. Evaporator: The evaporator shall be two circuit, direct expansion, shell-and-tube type with copper tubes rolled into steel tube sheets. It shall be insulated with 3/4

inch (19 mm) closed cell polyurethane insulation and designed for 150 psi (1034 kPa) water side working pressure and 354 psi (2441 kPa) refrigerant side pressure. It shall be designed in accordance with ASME Pressure Vessel Code, Section VIII, and have ANSI B9.1 pressure relief valves.

OPTION: The evaporator shall have 1 1/2 inch (40 mm) closed cell polyurethane insulation in lieu of standard 3/4 inch (19 mm).

OPTION: The evaporator shall have left-hand water connection when viewed from the control panel.

- E. Condensers: The remote air-cooled condensers shall consist of a cabinet, condenser coils multiple direct-drive propeller fans, fan guards and mounting legs. The condenser shall have seamless copper tubing mechanically expanded into aluminum OPTION: copper, plate type fins with full depth collars. The coil shall be “floating tube type” with refrigerant carrying tubes not touching the galvanized end plates. The headers to be field piped. The coil shall have an integral subcooler rated at ten degrees of subcooling at a 25-degree temperature difference. Coils shall be factory leak tested, dehydrated and connection ends spun closed. Fans shall have heavy gauge aluminum blades with painted steel spiders. Motors shall be dual voltage, 1140 rpm. OPTION: 830 rpm motors. The condenser shall be factory-equipped with head pressure control consisting of a fan motor VFD on one motor with the balance of motors cycled by unit-mounted pressure switches.
- F. Refrigerant Circuit: The unit shall have two or more refrigerant circuits, completely independent of each other. Each circuit shall be equipped with one compressor with integral oil separator, one microprocessor controller, a factory-mounted control circuit transformer, electronic expansion valve, discharge check and shutoff valve, liquid line shutoff valves, replaceable core filter-dryers, sight-glass with moisture indicator. Each circuit shall have field installed refrigerant piping from a discharge line connection on the indoor unit to the condenser and a liquid return line from the condenser to a liquid connection on the unit, upstream of the filter-drier. Each circuit shall be capable of operating independently; not being disabled in the event of a fault on the other circuit. OPTION: The compressor shall have a suction service shutoff valve
- G. Electric Panel: The electric panel shall consist of two separated sections, one for power components and one for control components. The control section shall contain a microprocessor controller for each circuit and one for the unit, providing operating and equipment protection controls. The circuit controllers shall operate independently of each other.

OPTION: The panel shall include a 115-volt convenience outlet.

OPTION: The panel shall be equipped with ground-fault protection.

The power section shall include solid state motor starters, a control transformer with primary and secondary fusing, microprocessor transformers with fusing, standard power blocks for each electrical circuit power connection, and switches for each circuit pumpdown and unit control power. The control panel shall have a hinged, lockable door.

OPTION: The unit shall have power connection to factory-installed, non-fused disconnect switches with through-the-door handles for each electric circuit.

OPTION: The unit shall have power connection to factory-installed, high interrupt current rated, non-fused disconnect switches with through-the-door handles for each electric circuit.

OPTION: The unit shall have a high short circuit rated panel with high interrupt current rated, non-fused disconnect switches with through-the-door handles for

each electric circuit.

OPTION: The unit shall have single point power connection to a factory-installed power block that is factory wired to a compressor isolation circuit breaker for each circuit.

OPTION: The unit shall have single point power connection to a factory-installed, non-fused disconnect switch with through-the-door handle that is factory wired to a compressor isolation circuit breaker for each circuit.

OPTION: The unit shall have single point power connection to a factory-installed, high interrupt current rated, non-fused disconnect switch with through-the-door handle that is factory wired to a compressor isolation circuit breaker for each circuit.

OPTION: The unit shall have a high short circuit rated panel with single point power connection to a factory-installed, high interrupt current rated, non-fused disconnect switch with through-the-door handle that is factory wired to a compressor isolation circuit breaker for each circuit.

The control system shall stage and load the compressors based on the leaving water temperature. Equipment protection devices controlled by the microprocessor shall include motor protection, high pressure, loss of refrigerant, loss of water flow, freeze protection, and low refrigerant pressure. Controls shall include auto/stop switch, chilled water setpoint adjustment, anti-recycle timer, and digital display with water temperature and setpoint, operating temperatures and pressures, and diagnostic messages. The following features and functions shall be included:

1. The control logic shall be designed to maximize operating efficiency and equipment life with protections for operation under unusual conditions. The system shall intelligently stage the unit to sustain leaving water temperature precision and stability while minimizing compressor cycling.
2. The following features and functions shall be included:
 - a. Durable liquid crystal display (LCD) screen type, having minimum four 20-character lines with 6 key input pad conveniently mounted on the unit controller. Default language and units of measure shall be English and I-P respectively. Messages shall be in plain English. Coded messages, LED indicators and LED displays are not acceptable.
 - b. Remote reset of chilled water temperature using a 4-20mA signal.
 - c. Soft-load operation, protecting the compressor by preventing full-load operation during the initial chilled fluid pull-down period.
 - d. BAS communication flexibility through the McQuay Open Choices™ feature. Optional modular plug-ins that enable the unit controller to communicate using standardized protocols such as LONTALK®, MODBUS® and BACnet®.

Factory mounted DDC controller(s) shall support operation on a BACnet®, Modbus® or LONMARKS® network via one of the data link / physical layers listed below as specified by the successful Building Automation System (BAS) supplier.

- BACnet MS/TP master (Clause 9)
- BACnet IP, (Annex J)
- BACnet ISO 8802-3, (Ethernet)
- LONMARKS FTT-10A. The unit controller shall be LONMARKS® certified.

The information communicated between the BAS and the factory mounted unit controllers shall include the reading and writing of data to allow unit monitoring, control and alarm notification as specified in the unit sequence of operation and the unit points list.

For chillers communicating over a LONMARKS network, the corresponding LONMARKS eXternal Interface File (XIF) shall be provided with the chiller submittal data.

All communication from the chiller unit controller as specified in the points list shall be via standard BACnet objects. Proprietary BACnet objects shall not be allowed. BACnet communications shall conform to the BACnet protocol (ANSI/ASHRAE135-2001). A BACnet Protocol Implementation Conformance Statement (PICS) shall be provided along with the unit submittal.

- e. Non-volatile program memory allowing auto-restart after a power failure without requiring a UPS (un-interruptible power supply).
 - f. Recording of safety shutdowns, including date-and-time stamp with system temperatures and pressures. A minimum of six previous occurrences shall be maintained in a revolving memory.
 - g. Start-to-start and stop-to-start cycle timers, providing minimum compressor off-time while maximizing motor protection.
 - h. Lead-lag compressor staging for part-load operation by manual selection or automatically by circuit run hours.
 - i. Pro-active compressor unloading when selected operating parameters exceed design settings, such as high discharge pressure or low evaporator pressure.
 - j. Diagnostic monitoring of unit operation, providing a pre-alarm signal in advance of a potential shutdown, allowing time for corrective action.
- H. The following options are to be included:
- Chilled water flow switch to be field mounted in the chilled water line and field wired to terminals in the control panel.
 - Rubber-In-Shear **OR** spring vibration isolators for field installation per plans.
 - Compressor acoustical enclosure for sound reduction.

PART 3 - EXECUTION

3.01 INSTALLATION

- A. Install in strict accordance with manufacturer's requirements, shop drawings, and contract documents.
- B. Adjust and level chiller in alignment on supports.
- C. Coordinate electrical installation with electrical contractor.
- D. Coordinate controls with control contractor.
- E. Provide all appurtenances required to ensure a fully operational and functional chiller.

3.02 START-UP

- A. Ensure proper charge of refrigerant and oil.
- B. Provide testing, and starting of machine, and instruct the Owner in its proper operation and maintenance.

All McQuay equipment is sold pursuant to McQuay's Standard Terms and Conditions of Sale and Limited Product Warranty. Consult your local McQuay Representative for warranty details. Refer to form 933-430285Y-00-A (09/08). To find your local representative, go to www.mcquay.com

This document contains the most current product information as of this printing. For the most up-to-date product information, please go to www.mcquay.com.

