



Product Data

AquaEdge®
19XR High-Efficiency Semi-Hermetic Centrifugal Liquid Chillers and
19XRV High-Efficiency Semi-Hermetic Centrifugal Liquid Chillers with Greenspeed® Intelligence
50/60 Hz
HFC-134a

200 to 3000 Nominal Tons (703 to 10551 kW)

greenspeed **AQUAEDGE**

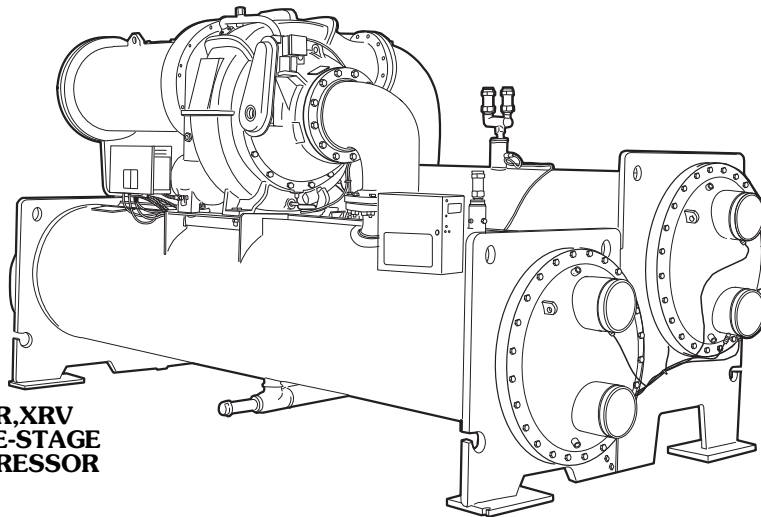

**19XR, XRV
SINGLE-STAGE
COMPRESSOR**

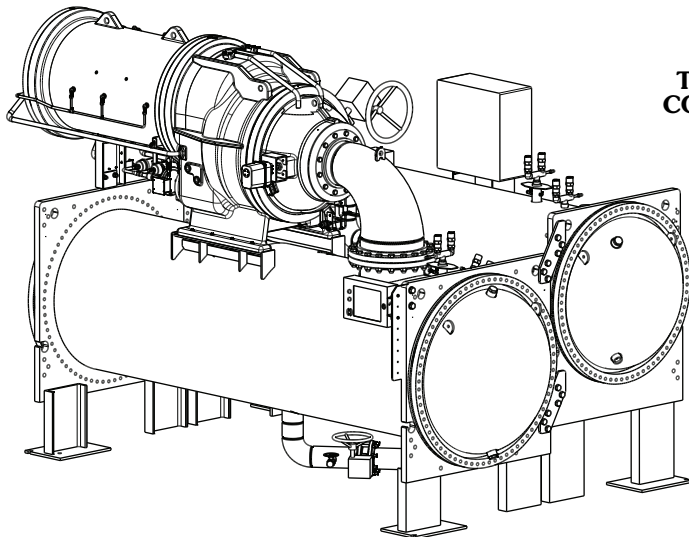

**19XR
TWO-STAGE
COMPRESSOR**

SEISMICOMPLIANT*

* Meets IBC 2006, ASCE-7-05, CBC 2007, and OSHPD seismic requirements.
Seismic rating available on select models.



Carrier's AquaEdge® centrifugal chillers offer:

- The use of non-ozone depleting refrigerant HFC-134a
- An annual leak rate of 0.1%, one of the lowest published in the industry
- The ability to store the entire charge of refrigerant inside the chiller, minimizing the chance of leaks during refrigerant transfer for maintenance
- Semi-hermetic compression
- Free-standing medium voltage VFD (variable frequency drive) (option)
- Modular construction
- Positive pressure design
- Variable diffuser optimization logic, which can improve the integrated part load values (IPLV) (available on compressor frame sizes 4 and 5 with diffuser control enabled)
- Single stage (200 to 1600 tons)
- Two stage (800 to 3000 tons)

Features/Benefits

The Carrier-designed AquaEdge family of chillers achieves high efficiencies without compromising the environment.

The AquaEdge chillers' high efficiencies are obtained at true operating conditions. Therefore, the effects of potential direct or indirect global warming are greatly diminished.

High efficiency

Today's owners of chilled water plants demand high efficiency from their chillers. Per AHRI (Air-Conditioning, Heating and Refrigeration Institute) 550/590 and 551/591, chillers operate at design conditions less than one percent of the time.

Features/Benefits (cont)



The AquaEdge® chiller efficiency levels meet or exceed energy efficiency requirements of ASHRAE (American Society of Heating, Refrigerating and Air-Conditioning Engineers) 90.1-2013.

As a result, superior part load efficiency is required for today's chilled water applications.

The AquaEdge® 19XR centrifugal chiller is offered as a fixed-speed machine or with an optional free-standing variable speed drive to maximize part load efficiency. The 19XRV chiller is equipped with a factory-installed variable speed drive.

The AquaEdge chiller with diffuser control enabled (available on compressor frame sizes 4 and 5) improves the chiller's part load efficiency by increasing the diffuser opening. Diffuser position is not only based on inlet guide vane (IGV) position, but also on lift.

Environmental leadership

Carrier has long been committed to the environment and its sustainability. AquaEdge chillers provide our customers with a high-efficiency, chlorine-free solution. Carrier's decision to utilize non-ozone depleting HFC-134a refrigerant provides our customers with a safer and more environmentally balanced choice without compromising efficiency.

Reliability

The AquaEdge chiller's single-stage or two-stage positive-pressure compressor, coupled with ASME (American Society of Mechanical Engineers) constructed heat exchangers, provides high reliability and sustainability. Carrier's semi-hermetic motors operate in a clean-liquid, refrigerant-cooled environment. The semi-hermetic design eliminates the potential for shaft seal leaks and refrigerant/oil loss. These are just some of the reasons why the AquaEdge family of chillers has one of the industry's lowest leak rates.

Positive pressure design

The AquaEdge chiller's positive pressure design reduces the chiller size by up to 35% compared to low-pressure designs. The smaller size minimizes the need for valuable mechanical room floor space. In addition, positive pressure designs eliminate the need for costly low-pressure containment

devices, reducing the initial cost of the system.

The AquaEdge chiller advantage

The AquaEdge chiller can be shipped fully charged, minimizing start-up and maintenance time. Purge units are not required. The tight construction of the AquaEdge centrifugal chiller ensures that contaminants stay out and efficiency is maintained throughout the life of the chiller.

Modular construction

The cooler, condenser, economizer, and compressor assemblies are completely bolted together, making the AquaEdge chillers ideally suited for replacement projects where ease of disassembly and reassembly at the jobsite are essential.

Marine container shipment (19XR, heat exchanger frame sizes 1 to 6 only)

The compact design allows for open-top container shipment to export destinations, ensuring product quality while reducing shipping cost.

Optional refrigerant isolation valves

This system allows the refrigerant to be stored inside the chiller during servicing, reducing refrigerant loss and eliminating time-consuming transfer procedures. As self-contained units, the AquaEdge chillers do not require additional remote storage systems.

Optional pumpdown unit

Combined with the refrigerant isolation valves listed above, the optional pumpdown unit eliminates complex connections to portable transfer systems, thereby reducing service costs. In

addition, the optional pumpdown compressor meets Environmental Protection Agency's (EPA's) vacuum level requirements that mandate minimizing refrigerant emissions during service.

Optional unit-mounted starter

Available in low-voltage wye-delta and solid state, Carrier's unit-mounted starter provides a single point power connection, reducing chiller installation time and expense. (Available on heat exchanger frame sizes 1 to 7 only.)

Optional seismic kit

A seismic isolation package is available on select models to meet International Building Code and ASCE (American Society of Civil Engineers) 7 seismic qualification requirements in concurrence with ICC ES (International Code Council Evaluation Service) AC156 Acceptance Criteria for Seismic Qualification by Shake-Table Testing of Nonstructural Components and Systems.

Semi-hermetic compressor features

Hydrodynamic journal bearings are featured for the fully supported motor shaft, and roller element bearings are featured for the high-speed impeller shaft for improved efficiency.

Pipe diffuser design uses jet engine technology, increasing centrifugal compressor peak efficiency (single-stage only).

Motors are hermetically sealed from the machine room; cooling is accomplished by spraying liquid refrigerant on the motor windings. This highly efficient motor cooling method results in the use of smaller, cooler-running

Table of contents

| | Page |
|-------------------------------------|-------|
| Features/Benefits | 1-6 |
| Model Number Nomenclature | 7,8 |
| Chiller Components | 9-14 |
| Physical Data | 15-48 |
| Options and Accessories | 49,50 |
| Dimensions | 51-54 |
| Selection Procedure | 55 |
| Electrical Data | 55 |
| Controls | 56 |
| Typical Piping and Wiring | 57,58 |
| Application Data | 59-76 |
| Guide Specifications | 77-87 |

motors than could be realized with air-cooled designs of the same type.

In addition, Carrier's semi-hermetic design eliminates:

- Compressor shaft seals that require maintenance and increase the likelihood of refrigerant leaks
- Shaft alignment problems that occur with open-drive designs during start-up and operation, when equipment temperature variations cause thermal expansion
- High noise levels that are common with air-cooled motors, which radiate noise to the machine room and adjacent areas
- Machine room cooling requirements associated with air-cooled motors, which dissipate heat to the machine room

Compressors are 100% run-tested to ensure proper operation of all compressor systems, including oil management, vibration, electrical, power transmission, and compression.

Heat exchanger features

The American Society of Mechanical Engineers (ASME) standard requires the use of an independent agency to certify the design, manufacture, and testing of all heat exchangers, ensuring the ultimate in heat exchanger safety, reliability, and long life.

Refrigerant-cooled VFD (19XRV) helps reduce VFD size and ensures proper cooling of the transistors for extended life. Using R-134a refrigerant instead of water also eliminates costly maintenance associated with the water cooling pump, heat exchanger and rubber tubing used with water-cooled VFDs.

1-in. tubes (optional) provide optimized cost and less pressure drop than the default 3/4-in. tubes.

Tube expansion at center support sheets prevents unwanted tube movement and vibration, thereby reducing the possibility of premature tube failure.

Double-grooved tube sheet holes reduce the possibility of leaks between the water and refrigerant system, increasing product reliability.

Condenser baffle prevents direct impingement of high velocity compressor gas onto the condenser tubes. The baffle eliminates the related vibration and

wear of the tubes and distributes the refrigerant flow evenly over the length of the vessel for improved efficiency.

Closely spaced intermediate support sheets prevent tube sagging and vibration, thereby increasing heat exchanger life.

Refrigerant filter drier isolation valves allow filter replacement without pumping down the chiller, which means less service time and less expense.

FLASC (flash subcooler), located in the bottom of the condenser, increases the refrigeration effect by cooling condensed liquid refrigerant to a lower temperature, resulting in reduced compressor power consumption.

Ball-type or linear float valves provide precise refrigerant metering over a wide variety of operating conditions. As a result, optimal refrigerant levels can be maintained in the condenser and cooler to achieve the greatest efficiency without unintentional hot gas bypass or flooding.

Microprocessor control features

Direct digital Product Integrated Control (PIC) provides unmatched flexibility and functionality. Each unit integrates directly with the Carrier Comfort Network® (CCN) system, providing a system solution to controls applications. The PIC control can be configured to display units in English or metric, and provides unparalleled ease of operation.

The default display offers all-in-one glance review of key chiller operation data, simplifying the interaction between chiller and user.

Features include:

- Display of over 125 operating, status, and diagnostic messages for improved user interface
- Monitoring of over 100 functions and conditions to protect the chiller from abnormal conditions
- Modular pull-out/plug-in design, reducing wiring requirements and providing easy installation
- Low-voltage (24 v) design, providing the ultimate assurance of personal safety and control integrity

The display modes include 4 standard languages:

- English

- Chinese
- Japanese (PIC II and PIC III only)
- Korean (PIC II and PIC III only)

Other languages are available.

Automatic capacity override function unloads the compressor whenever key safety limits are approached, increasing unit life.

Chilled water reset can be accomplished manually or automatically from the building management system. Reset saves energy when warmer chilled water can be used.

Demand limiting feature limits the power draw of the chiller during peak loading conditions. When incorporated into the Carrier Comfort Network® building automation system, a red line command holds chillers at their present capacity and prevents any other chillers from starting. If a load shed signal is received, the compressors are unloaded to avoid high demand charges whenever possible.

Ramp loading ensures a smooth pull-down of water loop temperature and prevents a rapid increase in compressor power consumption during the pulldown period.

Automated controls test can be executed prior to start-up to verify that the entire control system is functioning properly.

365-day real time clock feature allows the operator to program a yearly schedule for each week, weekends, and holidays.

Occupancy schedules can be programmed into the controller to ensure that the chiller only operates when cooling is required.

Extensive service menu features include password protection to prevent unauthorized access to the service menu. Built-in diagnostic capabilities assist in troubleshooting and recommend proper corrective action for pre-set alarms, resulting in greater operating time.

Alarm file maintains the last 25 time and date-stamped alarm and alert messages in memory; this function reduces troubleshooting time and cost.

Configuration data backup in non-volatile memory provides protection during power failures and eliminates time-consuming control reconfiguration.

Features/Benefits (cont)



19XR refrigeration cycle

The compressor continuously draws refrigerant vapor from the cooler at a rate set by the amount of guide vane opening. As the compressor suction reduces the pressure in the cooler, the remaining refrigerant boils at a fairly low temperature (typically 38 to 42 F [3 to 6 C]). The energy required for boiling is obtained from the water flowing through the cooler tubes. With heat energy removed, the water becomes cold enough to use in an air-conditioning circuit or process liquid cooling.

After taking heat from the water, the refrigerant vapor is compressed. Compression adds still more heat energy and the refrigerant is quite warm (typically 98 to 102 F [37 to 40 C]) when it is discharged from the compressor into the condenser.

Relatively cool (typically 65 to 90 F [18 to 32 C]) water flowing into the

condenser tubes removes heat from the refrigerant, and the vapor condenses to liquid.

The liquid refrigerant passes through orifices into the FLASC (flash subcooler) chamber. Since the FLASC chamber is at a lower pressure, part of the liquid refrigerant flashes to vapor, thereby cooling the remaining liquid. The FLASC vapor is recondensed on the tubes which are cooled by entering condenser water. The liquid drains into a float valve chamber between the FLASC chamber and cooler. Here, the AccuMeter™ float valve forms a liquid seal to keep FLASC chamber vapor from entering the cooler. When liquid refrigerant passes through the valve, some of it flashes to vapor in the reduced pressure on the cooler side. In flashing, it removes heat from the remaining liquid. The refrigerant is now at a temperature and pressure at which the cycle began. Refrigerant

from the condenser also cools the motor, oil and optional variable speed drive.

The refrigeration cycle for a 19XR, XRV chiller with two-stage compressor is similar to the one described above, with the following exception: Liquid refrigerant from the condenser flows into an economizer at intermediate pressure. In the economizer, vapor is separated from the liquid; the separated vapor flows to the second stage of the compressor and the liquid flows into the cooler. Since the economizer gas has to pass through only half of the compression cycle to reach condenser pressure, a saving in power is achieved. The energy removed from the vaporized refrigerant allows the liquid refrigerant in the cooler to absorb more heat when it evaporates and thereby benefits the cooling cycle.

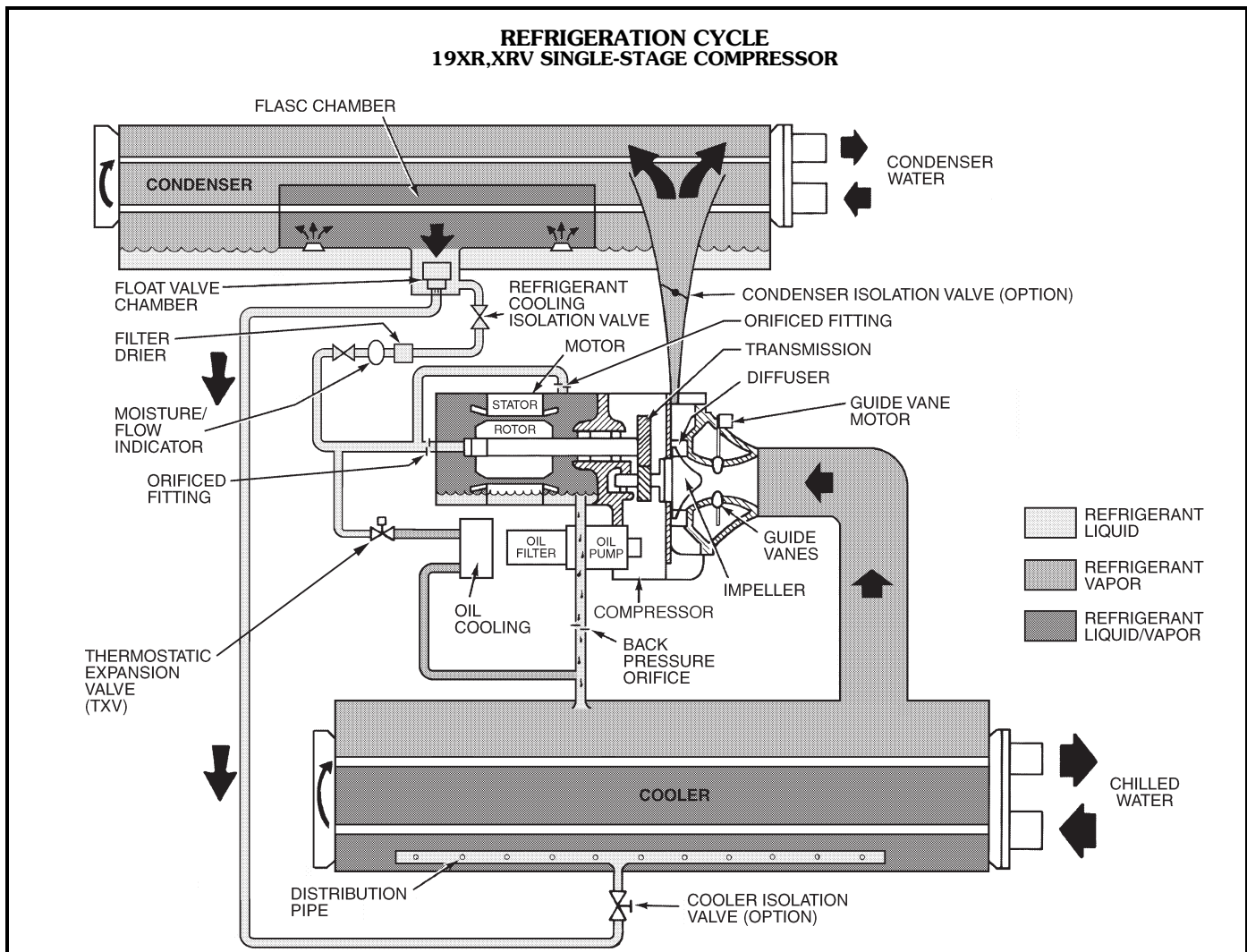

REFRIGERATION CYCLE (cont)
19XR,XRV TWO-STAGE COMPRESSOR FRAME SIZE E

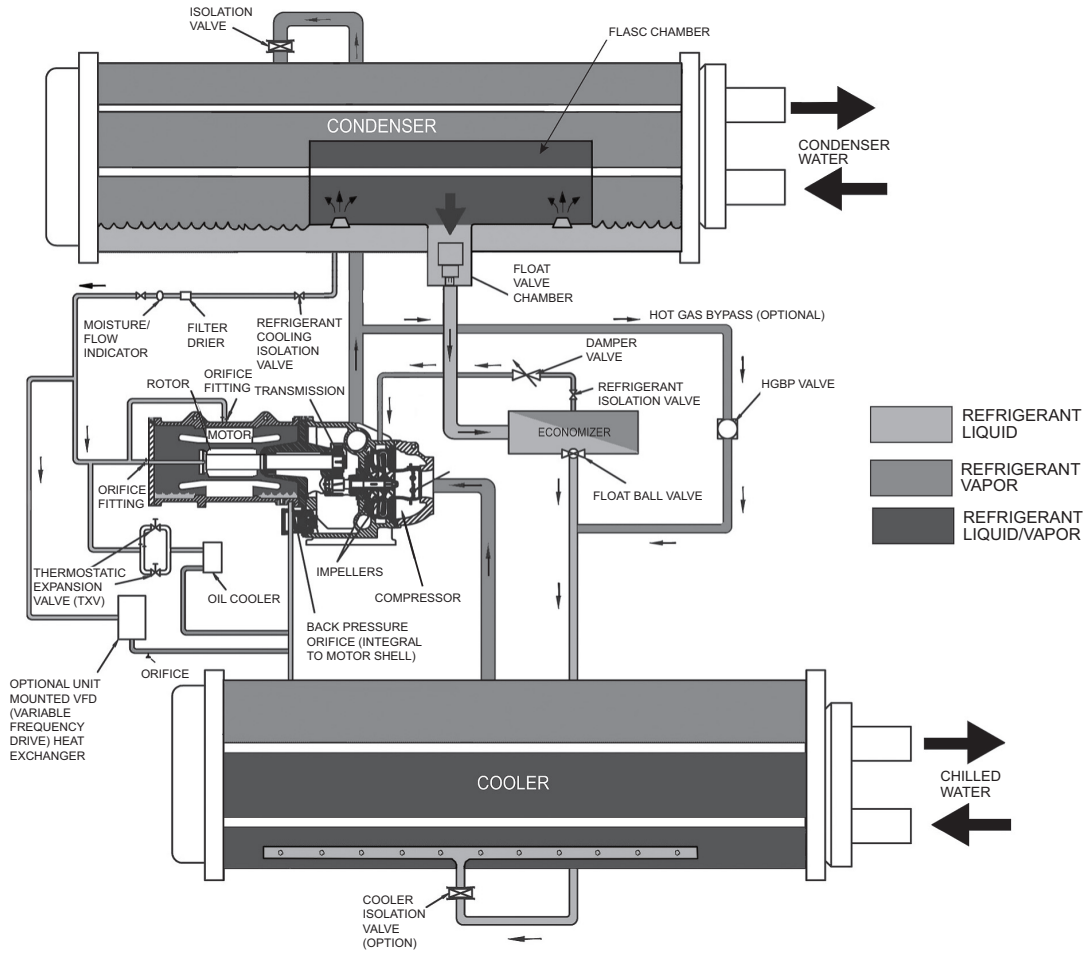

Features/Benefits (cont)

REFRIGERATION CYCLE (cont) 19XR TWO-STAGE COMPRESSOR FRAME SIZES 6 AND 7

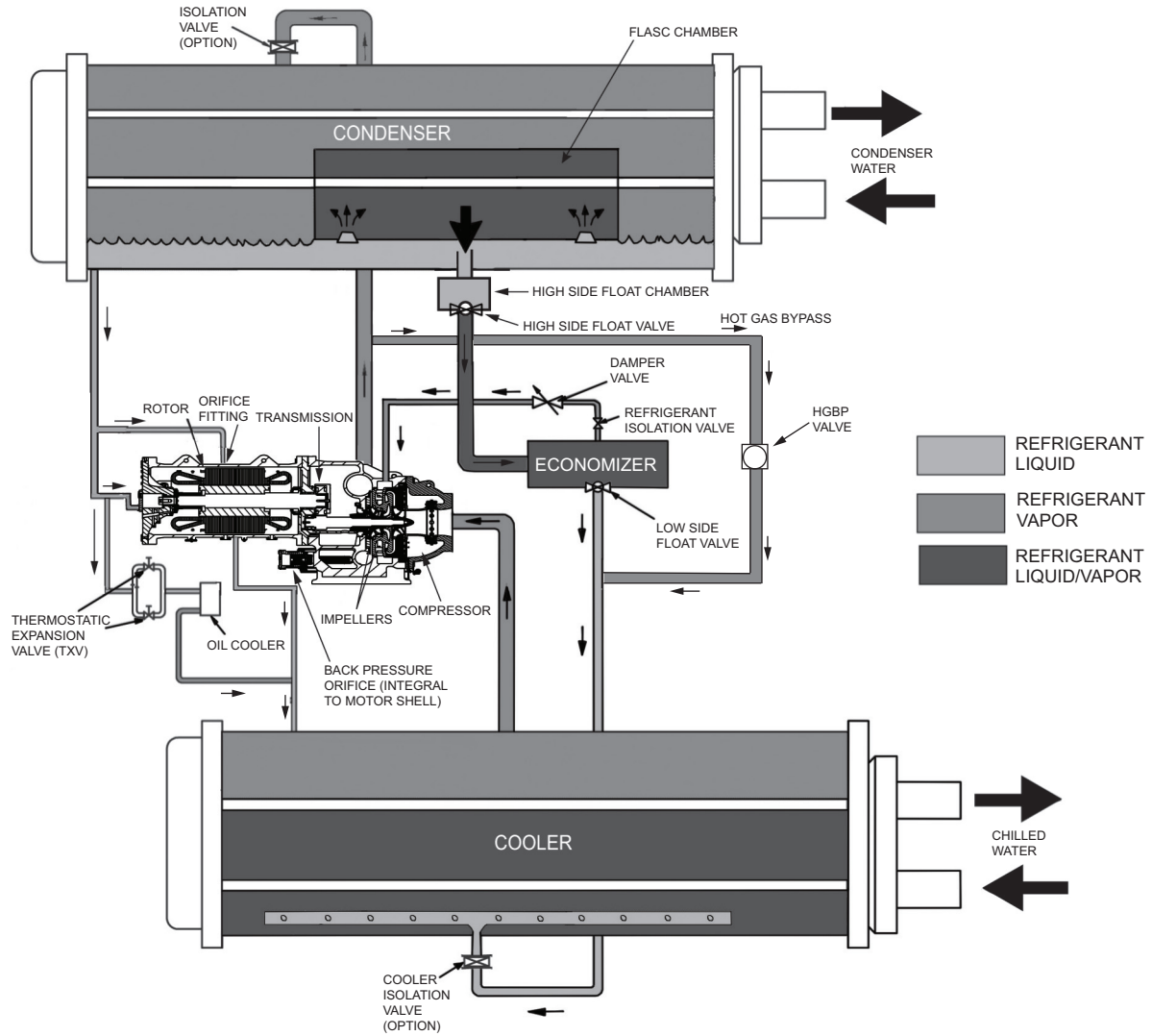

Model number nomenclature



19XR,XRV SINGLE-STAGE COMPRESSOR AND TWO-STAGE COMPRESSOR FRAME SIZE E

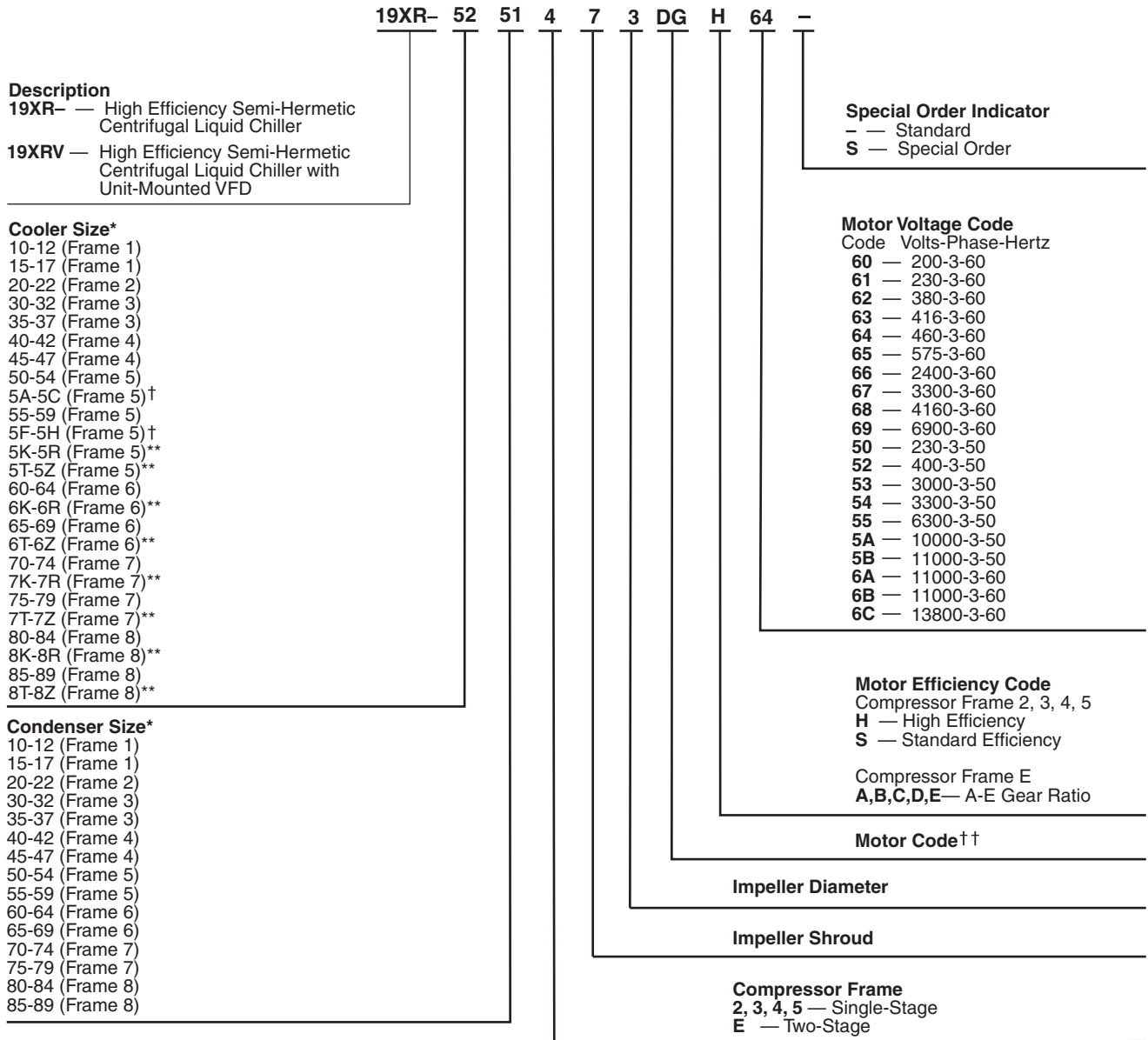

Quality Assurance

ISO 9001:2008 certified processes

AHRI (Air-Conditioning, Heating, and Refrigeration Institute) Performance Certified

*Frame sizes 1 through 6 available on single-stage units only.

†Refer to 19XR,XRV Computer Selection Program for details on these sizes.

** Frame sizes with K-R and T-Z are with 1 in. OD evaporator tubing.

††Refer to the 19XR,XRV Computer Selection Program for motor size details.

SEISMICOMPLIANT*

* Meets IBC 2006, ASCE-7-05, CBC 2007, and OSHPD seismic requirements.

Seismic rating available on select models.

Model number nomenclature (cont)



19XR TWO-STAGE COMPRESSOR FRAME SIZE 6 AND 7

| | 19XR- | A45 | A47 | 636 | M | N | 7 | - | |
|---|-------|-----|-----|-----|---|---|---|---|--|
| Description 19XR- — High Efficiency Semi-Hermetic Centrifugal Liquid Chiller | | | | | | | | | Special Order Indicator — — Standard S — Special Order |
| Cooler Size Code (Digits 6, 7, 8) A40-A42 A45-A47 A4A-A4C* A4F-A4H* A60-A62 A65-A67 A6A-A6C* A6F-A6H* B60-B62† B65-B67† B80-B82† B85-B87† B6A-B6C*† B6F-B6H*† B8A-B8C*† B8F-B8H*† C60-C62† C65-C67† C6A-C6C*† C6F-C6H*† | | | | | | | | | Motor Voltage Code Code Volts-Phase-Hertz: 4 — 3000-3-50 5 — 3300-3-50 6 — 6300-3-50 7 — 10000-3-50 8 — 11000-3-50 E — 2400-3-60 F — 3300-3-60 G — 4160-3-60 H — 6900-3-60 J — 11000-3-60 K — 13800-3-60 |
| Condenser Size Code (Digits 9, 10, 11) A40-A42 A45-A47 A4A-A4C* A4F-A4H* A60-A62 A65-A67 A6A-A6C* A6F-A6H* B40-B42 B45-B47 B4A-B4C* B4F-B4H* B60-B62* B65-B67* B6A-B6C* B6F-B6H* C60-C62† C65-C67† C80-C82† C85-C87† C6A-C6C*† C6F-C6H*† C8A-C8C*† C8F-C8H*† D60-D62† D65-D67† D6A-D6C*† D6F-D6H*† | | | | | | | | | Motor Size Code Compressor Frame Size N — 1500 HP P — 1625 HP Q — 1750 HP R — 1875 HP S — 2000 HP T — 2100 HP Compressor Frame Size U — 2250 HP V — 2375 HP W — 2500 HP X — 2625 HP Y — 2750 HP Z — 2900 HP |
| Compressor Size Code Frame Size (12th Digit) 6 — Frame Size 6 7 — Frame Size 7 | | | | | | | | | Gear Code Compressor Frame Size 6 E J M P Compressor Frame Size 7 R T V X Y |
| Shroud Size (13th Digit) 1 (Frame Size 7 Only) 2 3 4 (Frame Size 6 Only) | | | | | | | | | |
| Impeller Diameter (14th Digit) 2 4 6 8 0 | | | | | | | | | |

*Frame sizes with A-C and F-H are with 1-in. OD tubing.
†Heat exchanger available with frame 7 compressor only.



Quality Assurance
ISO 9001:2008 certified processes

AHRI (Air-Conditioning, Heating, and Refrigeration Institute)
Performance Certified

Compliance with UL 1995 (CSA C22.2 No. 236)

COMPRESSOR COMPONENTS 19XR,XRV SINGLE-STAGE COMPRESSOR

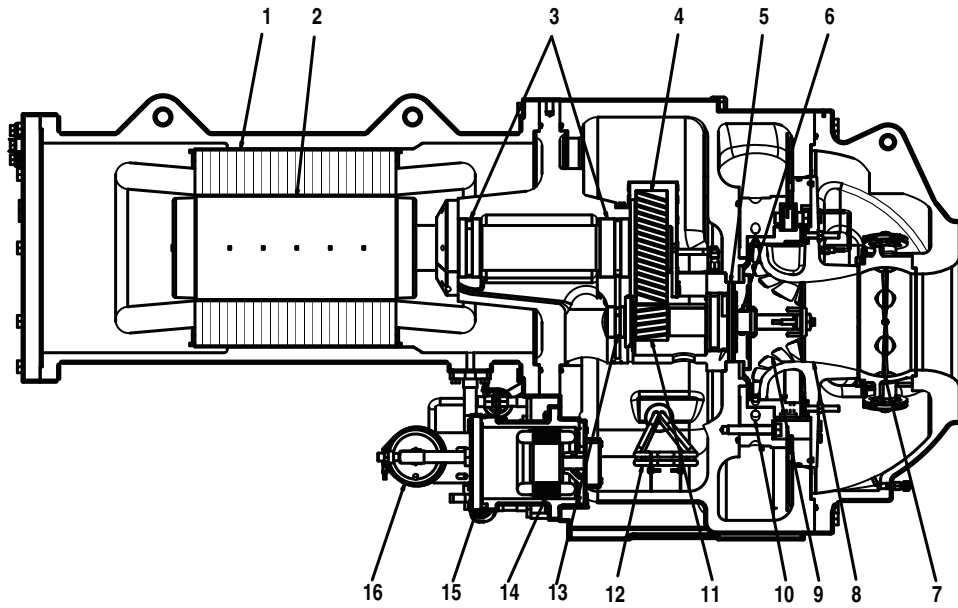

LEGEND

- | | |
|-------------------------------------|-------------------------------|
| 1 — Motor Stator | 9 — Impeller |
| 2 — Motor Rotor | 10 — Pipe Diffuser |
| 3 — Motor Shaft Journal Bearings | 11 — High Speed Pinion Gear |
| 4 — Low Speed Bull Gear | 12 — Oil Heater |
| 5 — High Speed Shaft Thrust Bearing | 13 — High Speed Shaft Bearing |
| 6 — High Speed Shaft Bearing | 14 — Oil Pump Motor |
| 7 — Variable Inlet Guide Vanes | 15 — Oil Pump Cover |
| 8 — Impeller Shroud | 16 — Oil Filter |

Chiller components (cont)

COMPRESSOR COMPONENTS 19XR, XRV TWO-STAGE COMPRESSOR FRAME SIZE E

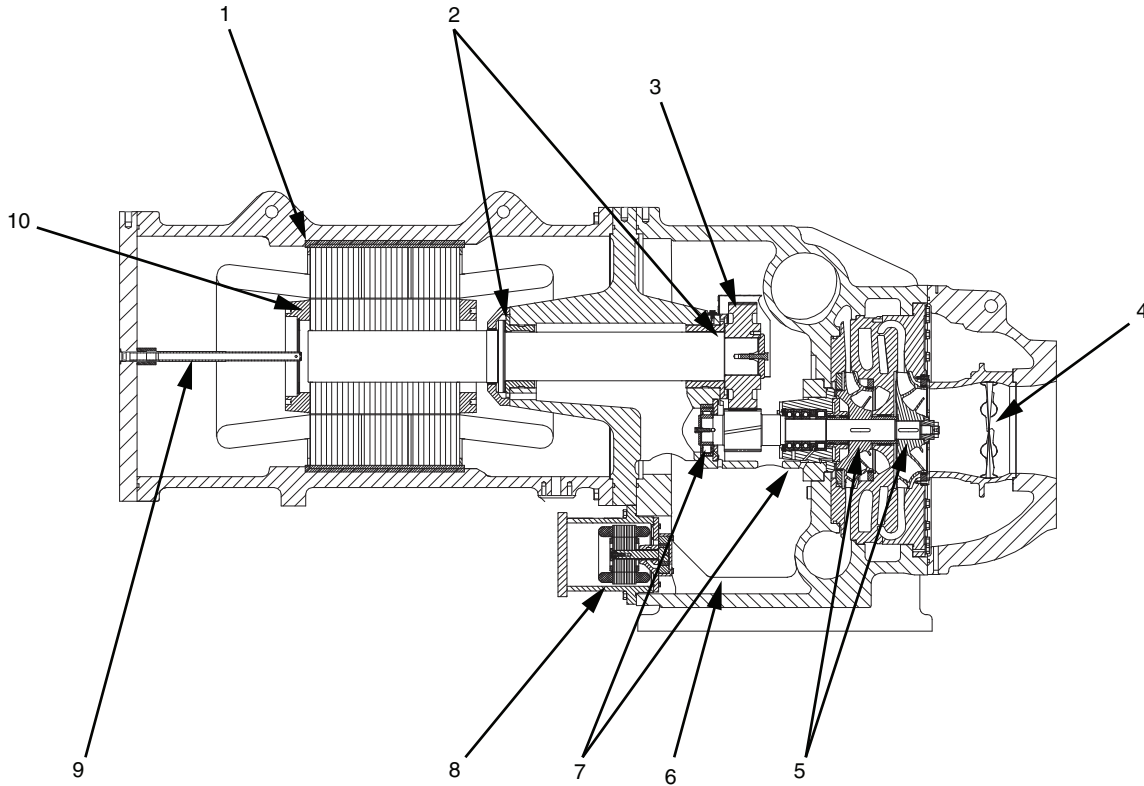

LEGEND

- | | |
|--------------------------------|-------------------------------|
| 1 — Motor Stator | 6 — Oil Heater |
| 2 — Motor Shaft Bearings | 7 — High Speed Shaft Bearings |
| 3 — Transmission | 8 — Oil Pump |
| 4 — Variable Inlet Guide Vanes | 9 — Motor Cooling |
| 5 — Impellers | 10 — Motor Rotor |

**COMPRESSOR COMPONENTS
19XR TWO-STAGE COMPRESSOR FRAME SIZES 6 AND 7**

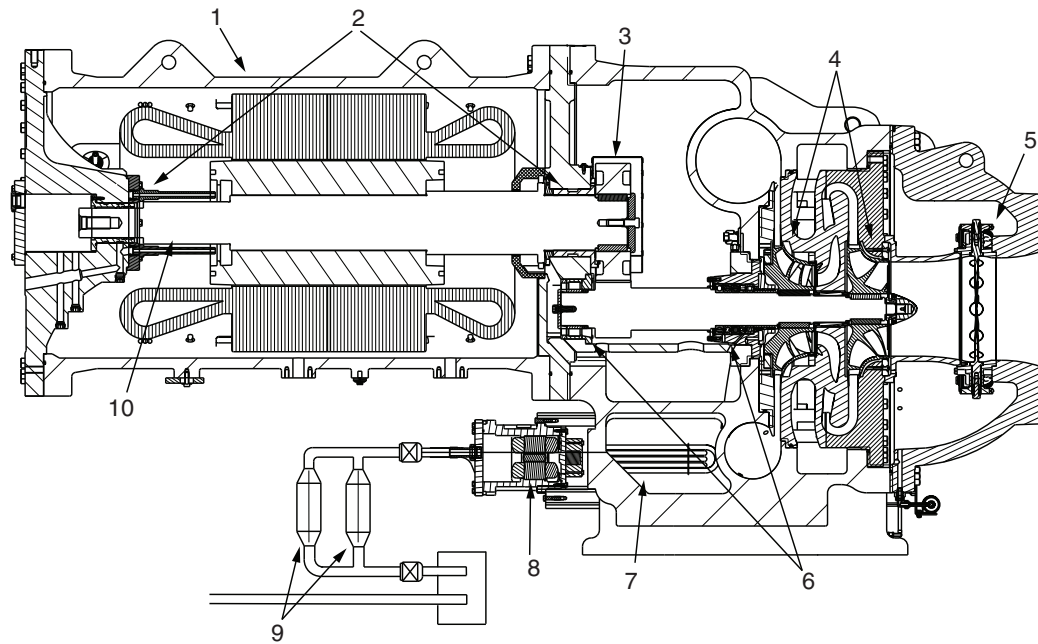

LEGEND

- | | |
|--------------------------------|-------------------------------|
| 1 — Motor Stator | 6 — High Speed Shaft Bearings |
| 2 — Motor Shaft Bearings | 7 — Oil Heater |
| 3 — Transmission | 8 — Oil Pump |
| 4 — Impellers | 9 — Oil Filters |
| 5 — Variable Inlet Guide Vanes | 10 — Motor Rotor |

Chiller components (cont)

19XR, XRV SINGLE-STAGE COMPRESSOR

FRONT VIEW

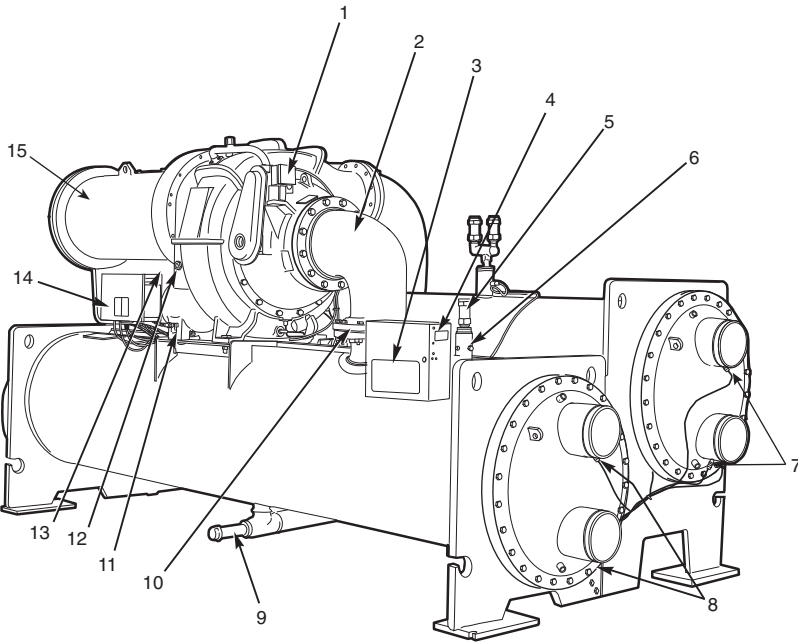

LEGEND

- 1 — Guide Vane Actuator
- 2 — Suction Elbow
- 3 — International Chiller Visual Control (ICVC)
- 4 — Chiller Identification Nameplate
- 5 — Cooler Auto Reset Relief Valves
- 6 — Cooler Pressure Transducer
- 7 — Condenser In/Out Temperature Thermistors
- 8 — Cooler In/Out Temperature Thermistors
- 9 — Refrigerant Storage Tank Connection Valve
- 10 — Typical Flange Connection
- 11 — Oil Drain Valve
- 12 — Oil Level Sight Glasses
- 13 — Refrigerant Oil Cooler (Hidden)
- 14 — Auxiliary Power Panel
- 15 — Motor Housing

REAR VIEW

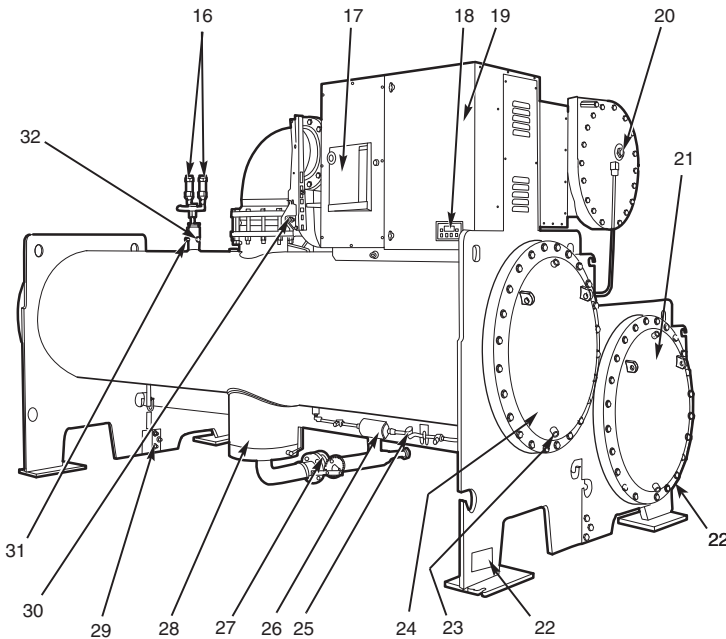

LEGEND

- 16 — Condenser Auto. Reset Relief Valves
- 17 — Motor Circuit Breaker
- 18 — Solid-State Starter Control Display
- 19 — Unit-Mounted Starter or VFD (Optional)
Solid-State Starter Shown
- 20 — Motor Sight Glass
- 21 — Cooler Return-End Waterbox Cover
- 22 — ASME Nameplate (One Hidden)
- 23 — Typical Waterbox Drain Port
- 24 — Condenser Return-End Waterbox Cover
- 25 — Refrigerant Moisture/Flow Indicator
- 26 — Refrigerant Filter/Drier
- 27 — Liquid Line Isolation Valve (Optional)
- 28 — Liquid Float Valve Chamber
- 29 — Vessel Take-Apart Connector
- 30 — Discharge Isolation Valve (Optional)
- 31 — Condenser Pressure Transducer
- 32 — Refrigerant Charging Valve/Pumpout Connection

19XR,XRV TWO-STAGE COMPRESSOR FRAME SIZE E

FRONT VIEW

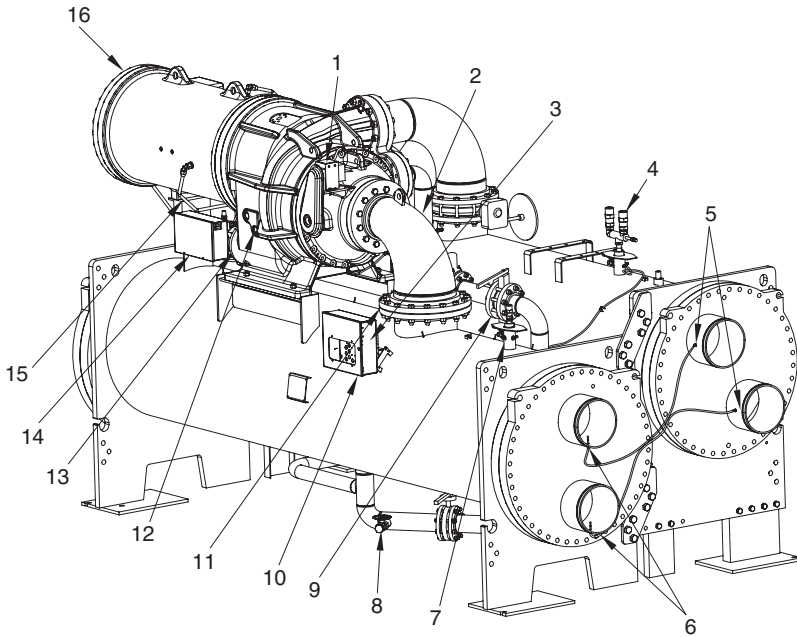

LEGEND

- 1 — Guide Vane Actuator
- 2 — Suction Elbow
- 3 — Chiller Identification Nameplate
- 4 — Condenser Auto Reset Relief Valves
- 5 — Condenser In/Out Temperature Thermistors
- 6 — Cooler In/Out Temperature Thermistors
- 7 — Cooler Pressure Transducer
- 8 — Refrigerant Storage Tank Connection Valve
- 9 — Refrigerant Isolation Valve
- 10 — Chiller Visual Controller/ International Chiller Visual Control (ICVC)
- 11 — Typical Flange Connection
- 12 — Oil Level Sight Glasses
- 13 — Oil Drain Charging Valve
- 14 — Auxiliary Power Panel
- 15 — Refrigerant Oil Cooler (Hidden)
- 16 — Compressor Motor Housing

REAR VIEW

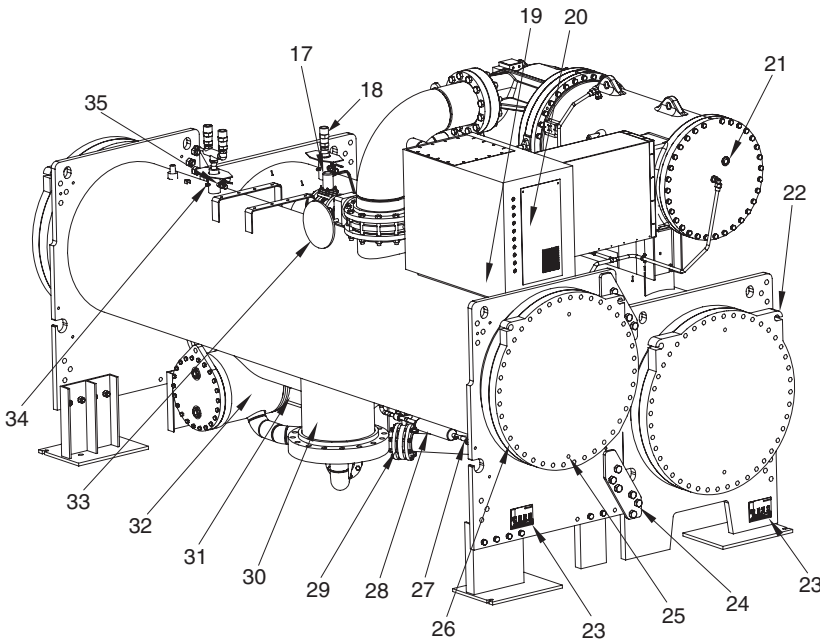

LEGEND

- 17 — Damper Valve (Hidden)
- 18 — Cooler Auto. Reset Relief Valves
- 19 — Solid-State Starter Control Display (Optional)
- 20 — Unit-Mounted Starter (Optional)
- 21 — Motor Sight Glass
- 22 — Cooler Return-End Waterbox Cover
- 23 — ASME Nameplate
- 24 — Vessel Take-Apart Connector
- 25 — Typical Waterbox Drain Port
- 26 — Condenser Return-End Waterbox Cover
- 27 — Refrigerant Moisture/Flow Indicator
- 28 — Refrigerant Filter/Drier
- 29 — Liquid Line Isolation Valve (Optional)
- 30 — Linear Float Valve Chamber
- 31 — Economizer Assembly
- 32 — Economizer Float Ball Valve Assembly (Inside)
- 33 — Discharge Isolation Valve (Optional)
- 34 — Condenser Pressure Transducer
- 35 — Refrigerant Charging Valve/Pumpout Connection

Chiller components (cont)

19XR TWO-STAGE COMPRESSOR FRAME SIZES 6 AND 7

FRONT VIEW

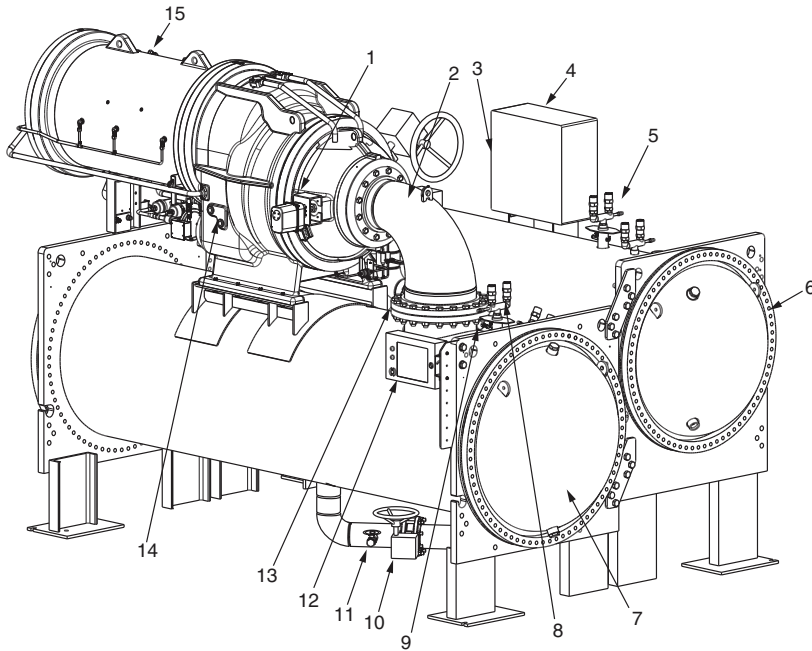

LEGEND

- 1 — Guide Vane Actuator*
- 2 — Suction Elbow
- 3 — Chiller Identification Nameplate
- 4 — Auxiliary Power Panel
- 5 — Condenser Auto. Reset Relief Valves
- 6 — Condenser Return End Waterbox Cover
- 7 — Cooler Return End Waterbox Cover
- 8 — Cooler Auto. Reset Relief Valves
- 9 — Cooler Pressure Transducer
- 10 — Liquid Line Isolation Valve (Optional)
- 11 — Refrigerant Storage Tank Connection Valve
- 12 — HMI (Human Machine Interface) Panel
- 13 — Typical Flange Connection
- 14 — Oil Level Sight Glasses
- 15 — Compressor Motor Housing

*See certified drawing for Frame 7 location.

REAR VIEW

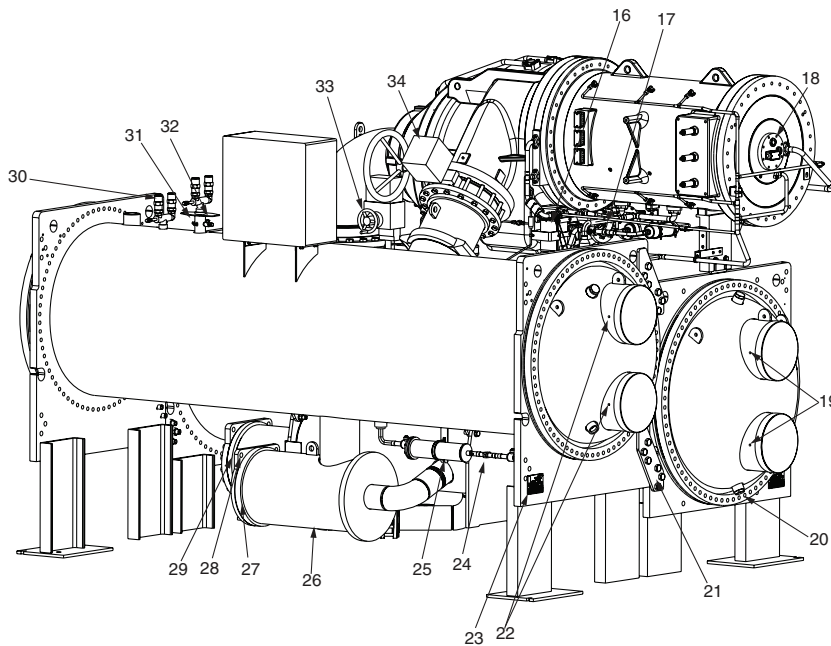

LEGEND

- 16 — Oil Cooler
- 17 — Oil Drain Changing Valve (Hidden)
- 18 — Motor Sight Glass
- 19 — Cooler In/Out Temperature Thermistors
- 20 — Typical Waterbox Drain Port
- 21 — Vessel Take-Apart Connector
- 22 — Condenser In/Out Temperature Thermistors
- 23 — ASME Nameplate
- 24 — Refrigerant Moisture/Flow Indicator
- 25 — Refrigerant Filter/Drier
- 26 — High Side Float Chamber
- 27 — High Side Float Ball Valve Assembly (Inside)
- 28 — Economizer Assembly
- 29 — Economizer Float Ball Assembly (Inside)
- 30 — Cooler Auto. Reset Relief Valve
- 31 — Condenser Pressure Transducer
- 32 — Refrigerant Charging Valve/Pumpout Connection
- 33 — Damper Valve
- 34 — Discharge Isolation Valve (Optional)

NOTE: Frame 6 is shown.

Physical data



19XR,XRV COMPRESSOR AND MOTOR WEIGHTS*— STANDARD AND HIGH-EFFICIENCY MOTORS

COMPRESSOR FRAME SIZE 2†

| MOTOR CODE | ENGLISH | | | | | | SI | | | | | |
|---|--------------------------|----------------------|-------------------|----------------------|-------------------|----------------------------|--------------------------|----------------------|-------------------|----------------------|-------------------|----------------------------|
| | Compressor Weight** (lb) | 60 Hz | | 50 Hz | | End Bell Cover Weight (lb) | Compressor Weight** (kg) | 60 Hz | | 50 Hz | | End Bell Cover Weight (kg) |
| | | Stator Weight†† (lb) | Rotor Weight (lb) | Stator Weight†† (lb) | Rotor Weight (lb) | | | Stator Weight†† (kg) | Rotor Weight (kg) | Stator Weight†† (kg) | Rotor Weight (kg) | |
| STANDARD-EFFICIENCY MOTORS / LOW VOLTAGE (200-575 v) | | | | | | | | | | | | |
| BDS | 2300 | 900 | 190 | 915 | 205 | 185 | 1043 | 408 | 86 | 415 | 93 | 84 |
| BES | 2300 | 915 | 200 | 965 | 220 | 185 | 1043 | 415 | 91 | 438 | 100 | 84 |
| BFS | 2300 | 975 | 215 | 1000 | 230 | 185 | 1043 | 442 | 98 | 454 | 104 | 84 |
| BGS | 2300 | 1000 | 230 | 1060 | 250 | 185 | 1043 | 454 | 104 | 481 | 113 | 84 |
| BHS | 2300 | 1030 | 240 | 1105 | 265 | 185 | 1043 | 467 | 109 | 501 | 120 | 84 |
| BJS | 2300 | 1105 | 265 | — | — | 185 | 1043 | 501 | 120 | — | — | 84 |
| HIGH-EFFICIENCY MOTORS / LOW VOLTAGE (200-575 v) | | | | | | | | | | | | |
| BDH | 2300 | 1030 | 240 | 1030 | 240 | 185 | 1043 | 467 | 109 | 467 | 109 | 84 |
| BEH | 2300 | 1070 | 250 | 1070 | 250 | 185 | 1043 | 485 | 113 | 485 | 113 | 84 |
| BFH | 2300 | 1120 | 265 | 1120 | 265 | 185 | 1043 | 508 | 120 | 508 | 120 | 84 |
| BGH | 2300 | 1175 | 290 | 1175 | 290 | 185 | 1043 | 533 | 132 | 533 | 132 | 84 |
| BHH | 2300 | 1175 | 290 | 1175 | 290 | 185 | 1043 | 533 | 132 | 533 | 132 | 84 |
| BJH | 2300 | 1175 | 290 | — | — | 185 | 1043 | 533 | 132 | — | — | 84 |
| JBH | 2300 | 1003 | 226 | 1063 | 248 | 185 | 1043 | 455 | 103 | 482 | 112 | 84 |
| JCH | 2300 | 1063 | 248 | 1113 | 263 | 185 | 1043 | 482 | 112 | 505 | 119 | 84 |
| JDH | 2300 | 1113 | 263 | 1149 | 278 | 185 | 1043 | 505 | 119 | 521 | 126 | 84 |
| JEH | 2300 | 1149 | 278 | 1196 | 295 | 185 | 1043 | 521 | 126 | 542 | 134 | 84 |
| JFH | 2300 | 1196 | 295 | — | — | 185 | 1043 | 542 | 134 | — | — | 84 |

*Total compressor weight is the sum of the compressor aerodynamic components (compressor weight column), stator, rotor, and end bell cover weights.

†See Model Number Nomenclature on page 7.

**Compressor aerodynamic component weight only, motor weight not included. Applicable to standard compressors only. For high lift compressors, contact Carrier Chiller Marketing for weights.

††Stator weight includes the stator and shell.

Physical data (cont)



19XR,XRV COMPRESSOR AND MOTOR WEIGHTS*— STANDARD AND HIGH-EFFICIENCY MOTORS (cont)

COMPRESSOR FRAME SIZE 3†

| MOTOR CODE | ENGLISH | | | | | | SI | | | | | |
|---|--------------------------|----------------------|-------------------|----------------------|-------------------|----------------------------|--------------------------|----------------------|-------------------|----------------------|-------------------|----------------------------|
| | Compressor Weight** (lb) | 60 Hz | | 50 Hz | | End Bell Cover Weight (lb) | Compressor Weight** (kg) | 60 Hz | | 50 Hz | | End Bell Cover Weight (kg) |
| | | Stator Weight†† (lb) | Rotor Weight (lb) | Stator Weight†† (lb) | Rotor Weight (lb) | | | Stator Weight†† (kg) | Rotor Weight (kg) | Stator Weight†† (kg) | Rotor Weight (kg) | |
| STANDARD-EFFICIENCY MOTORS / LOW VOLTAGE (200-575 v) | | | | | | | | | | | | |
| CBS | 2816 | 1146 | 219 | 1188 | 236 | 274 | 1277 | 520 | 99 | 539 | 107 | 124 |
| CCS | 2816 | 1171 | 227 | 1196 | 242 | 274 | 1277 | 531 | 103 | 542 | 110 | 124 |
| CDS | 2816 | 1198 | 237 | 1258 | 255 | 274 | 1277 | 543 | 108 | 571 | 116 | 124 |
| CES | 2816 | 1207 | 240 | 1272 | 258 | 274 | 1277 | 547 | 109 | 577 | 117 | 124 |
| CLS | 2816 | 1247 | 249 | 1328 | 273 | 274 | 1277 | 566 | 113 | 602 | 124 | 124 |
| CMS | 2816 | 1270 | 257 | 1353 | 278 | 274 | 1277 | 576 | 117 | 614 | 126 | 124 |
| CNS | 2816 | 1321 | 266 | 1386 | 282 | 274 | 1277 | 599 | 121 | 629 | 128 | 124 |
| CPS | 2816 | 1334 | 269 | 1401 | 287 | 274 | 1277 | 605 | 122 | 635 | 130 | 124 |
| CQS | 2816 | 1353 | 276 | 1408 | 290 | 274 | 1277 | 614 | 125 | 639 | 132 | 124 |
| CRS | 2816 | 1259 | 321 | — | — | 274 | 1277 | 571 | 146 | — | — | 124 |
| CRS (380v) | 2816 | 1328 | 346 | — | — | 274 | 1277 | 602 | 157 | — | — | 124 |
| HIGH-EFFICIENCY MOTORS / LOW VOLTAGE (200-575 v) | | | | | | | | | | | | |
| CBH | 2816 | 1235 | 239 | 1290 | 254 | 274 | 1277 | 560 | 108 | 585 | 115 | 124 |
| CCH | 2816 | 1260 | 249 | 1295 | 259 | 274 | 1277 | 572 | 113 | 587 | 117 | 124 |
| CDH | 2816 | 1286 | 258 | 1358 | 273 | 274 | 1277 | 583 | 117 | 616 | 124 | 124 |
| CEH | 2816 | 1305 | 265 | 1377 | 279 | 274 | 1277 | 592 | 120 | 625 | 127 | 124 |
| CLH | 2816 | 1324 | 271 | 1435 | 292 | 274 | 1277 | 601 | 123 | 651 | 132 | 124 |
| CMH | 2816 | 1347 | 275 | 1455 | 298 | 274 | 1277 | 611 | 125 | 660 | 135 | 124 |
| CNH | 2816 | 1358 | 278 | 1467 | 301 | 274 | 1277 | 616 | 126 | 665 | 137 | 124 |
| CPH | 2816 | 1401 | 290 | 1479 | 304 | 274 | 1277 | 635 | 132 | 671 | 138 | 124 |
| CQH | 2816 | 1455 | 304 | 1479 | 304 | 274 | 1277 | 670 | 138 | 671 | 138 | 124 |
| KBH | 2816 | 1313 | 276 | 1353 | 285 | 274 | 1277 | 596 | 125 | 614 | 129 | 124 |
| KCH | 2816 | 1353 | 285 | 1381 | 291 | 274 | 1277 | 614 | 129 | 626 | 132 | 124 |
| KDH | 2816 | 1381 | 291 | 1417 | 307 | 274 | 1277 | 626 | 132 | 643 | 139 | 124 |
| KEH | 2816 | 1417 | 307 | 1441 | 313 | 274 | 1277 | 643 | 139 | 654 | 142 | 124 |
| KFH | 2816 | 1441 | 313 | 1470 | 320 | 274 | 1277 | 654 | 142 | 667 | 145 | 124 |
| KGH | 2816 | 1470 | 320 | 1505 | 333 | 274 | 1277 | 667 | 145 | 683 | 151 | 124 |
| KHH | 2816 | 1505 | 333 | — | — | 274 | 1277 | 683 | 151 | — | — | 124 |

*Total compressor weight is the sum of the compressor aerodynamic components (compressor weight column), stator, rotor, and end bell cover weights.

†See Model Number Nomenclature on page 7.

**Compressor aerodynamic component weight only, motor weight not included. Applicable to standard compressors only. For high lift compressors, contact Carrier Chiller Marketing for weights.

††Stator weight includes the stator and shell.

**19XR,XRV COMPRESSOR AND MOTOR WEIGHTS*—
STANDARD AND HIGH-EFFICIENCY MOTORS (cont)
COMPRESSOR FRAME SIZE 4†**

| MOTOR CODE | ENGLISH | | | | | | SI | | | | | |
|--|---|----------------------|-------------------|----------------------|-------------------|----------------------------|---|----------------------|-------------------|----------------------|-------------------|----------------------------|
| | Compressor Weight** (lb) Fixed Ring/ Split Ring | 60 Hz | | 50 Hz | | End Bell Cover Weight (lb) | Compressor Weight** (kg) Fixed Ring/ Split Ring | 60 Hz | | 50 Hz | | End Bell Cover Weight (kg) |
| | | Stator Weight†† (lb) | Rotor Weight (lb) | Stator Weight†† (lb) | Rotor Weight (lb) | | | Stator Weight†† (kg) | Rotor Weight (kg) | Stator Weight†† (kg) | Rotor Weight (kg) | |
| STANDARD-EFFICIENCY MOTORS / LOW VOLTAGE (200-575 v) | | | | | | | | | | | | |
| DBS | 3425 / 4211 | 1570 | 324 | 1725 | 347 | 236 | 1554 / 1910 | 712 | 147 | 782 | 157 | 107 |
| DCS | 3425 / 4211 | 1580 | 326 | 1737 | 352 | 236 | 1554 / 1910 | 717 | 148 | 788 | 160 | 107 |
| DDS | 3425 / 4211 | 1595 | 329 | 1749 | 357 | 236 | 1554 / 1910 | 723 | 149 | 793 | 162 | 107 |
| DES | 3425 / 4211 | 1685 | 345 | 1762 | 365 | 236 | 1554 / 1910 | 764 | 156 | 799 | 166 | 107 |
| DFS | 3425 / 4211 | 1690 | 348 | 1801 | 372 | 236 | 1554 / 1910 | 767 | 158 | 817 | 169 | 107 |
| DGS | 3425 / 4211 | 1692 | 352 | 1858 | 386 | 236 | 1554 / 1910 | 767 | 160 | 843 | 175 | 107 |
| DHS | 3425 / 4211 | 1774 | 366 | 1904 | 398 | 236 | 1554 / 1910 | 805 | 166 | 864 | 181 | 107 |
| DJS | 3425 / 4211 | — | — | 2020 | 401 | 318 | 1554 / 1910 | — | — | 916 | 182 | 142 |
| STANDARD-EFFICIENCY MOTORS / MEDIUM VOLTAGE (2400-4160 v) | | | | | | | | | | | | |
| DBS | 3425 / 4211 | 1524 | 296 | 1637 | 327 | 236 | 1554 / 1910 | 691 | 134 | 743 | 148 | 107 |
| DCS | 3425 / 4211 | 1569 | 307 | 1685 | 354 | 236 | 1554 / 1910 | 712 | 139 | 764 | 161 | 107 |
| DDS | 3425 / 4211 | 1588 | 313 | 1713 | 357 | 236 | 1554 / 1910 | 720 | 142 | 777 | 162 | 107 |
| DES | 3425 / 4211 | 1613 | 324 | 1746 | 360 | 236 | 1554 / 1910 | 732 | 147 | 792 | 163 | 107 |
| DFS | 3425 / 4211 | 1675 | 347 | 1811 | 381 | 236 | 1554 / 1910 | 760 | 157 | 821 | 173 | 107 |
| DGS | 3425 / 4211 | 1704 | 355 | 1998 | 422 | 236 (60 Hz) 318 (50 Hz) | 1554 / 1910 | 773 | 161 | 906 | 191 | 107 (60 Hz) 142 (50 Hz) |
| DHS | 3425 / 4211 | 1737 | 361 | 2056 | 443 | 236 (60 Hz) 318 (50 Hz) | 1554 / 1910 | 788 | 164 | 933 | 201 | 107 (60 Hz) 142 (50 Hz) |
| DJS | 3425 / 4211 | 1769 | 365 | 2101 | 464 | 236 (60 Hz) 318 (50 Hz) | 1554 / 1910 | 802 | 166 | 953 | 210 | 107 (60 Hz) 142 (50 Hz) |
| STANDARD-EFFICIENCY MOTORS / MEDIUM VOLTAGE (6300-6900 v) | | | | | | | | | | | | |
| DDS | 3425 / 4211 | 1919 | 423 | 2069 | 458 | 318 | 1554 / 1910 | 870 | 192 | 938 | 208 | 142 |
| DES | 3425 / 4211 | 1939 | 428 | 2089 | 463 | 318 | 1554 / 1910 | 880 | 194 | 947 | 210 | 142 |
| DFS | 3425 / 4211 | 1989 | 448 | 2139 | 478 | 318 | 1554 / 1910 | 902 | 203 | 970 | 217 | 142 |
| DGS | 3425 / 4211 | 2054 | 473 | — | — | 318 | 1554 / 1910 | 932 | 215 | — | — | 142 |
| DHS | 3425 / 4211 | 2099 | 488 | — | — | 318 | 1554 / 1910 | 952 | 221 | — | — | 142 |
| DJS | 3425 / 4211 | 2159 | 508 | — | — | 318 | 1554 / 1910 | 979 | 230 | — | — | 142 |
| HIGH-EFFICIENCY MOTORS / LOW VOLTAGE (200-575 v) | | | | | | | | | | | | |
| DBH | 3425 / 4211 | 1773 | 406 | 1827 | 406 | 318 | 1554 / 1910 | 804 | 184 | 829 | 184 | 142 |
| DCH | 3425 / 4211 | 1827 | 406 | 1827 | 414 | 318 | 1554 / 1910 | 829 | 184 | 829 | 188 | 142 |
| DDH | 3425 / 4211 | 1827 | 414 | 1881 | 422 | 318 | 1554 / 1910 | 829 | 188 | 853 | 191 | 142 |
| DEH | 3425 / 4211 | 1881 | 422 | 1881 | 422 | 318 | 1554 / 1910 | 853 | 191 | 853 | 191 | 142 |
| DFH | 3425 / 4211 | 1881 | 439 | 1963 | 439 | 318 | 1554 / 1910 | 853 | 199 | 890 | 199 | 142 |
| DGH | 3425 / 4211 | 1963 | 455 | 1963 | 455 | 318 | 1554 / 1910 | 890 | 206 | 890 | 206 | 142 |
| DHH | 3425 / 4211 | 1963 | 455 | 2050 | 463 | 318 | 1554 / 1910 | 890 | 206 | 930 | 210 | 142 |
| DJH | 3425 / 4211 | — | — | 2050 | 471 | 318 | 1554 / 1910 | — | — | 930 | 213 | 142 |
| DKH | 3425 / 4211 | 2050 | 471 | — | — | 318 | 1554 / 1910 | 930 | 214 | — | — | 142 |

*Total compressor weight is the sum of the compressor aerodynamic components (compressor weight column), stator, rotor, and end bell cover weights.

†See Model Number Nomenclature on page 7.

**Compressor aerodynamic component weight only, motor weight not included. Applicable to standard compressors only. For high lift compressors, contact Carrier Chiller Marketing for weights.

††Stator weight includes the stator and shell.

Physical data (cont)



19XR,XRV COMPRESSOR AND MOTOR WEIGHTS*— STANDARD AND HIGH-EFFICIENCY MOTORS (cont) COMPRESSOR FRAME SIZE 4† (cont)

| MOTOR CODE | ENGLISH | | | | | | SI | | | | | |
|--|---|----------------------|-------------------|----------------------|-------------------|----------------------------|---|----------------------|-------------------|----------------------|-------------------|----------------------------|
| | Compressor Weight** (lb) Fixed Ring/ Split Ring | 60 Hz | | 50 Hz | | End Bell Cover Weight (lb) | Compressor Weight** (kg) Fixed Ring/ Split Ring | 60 Hz | | 50 Hz | | End Bell Cover Weight (kg) |
| | | Stator Weight†† (lb) | Rotor Weight (lb) | Stator Weight†† (lb) | Rotor Weight (lb) | | | Stator Weight†† (kg) | Rotor Weight (kg) | Stator Weight†† (kg) | Rotor Weight (kg) | |
| HIGH-EFFICIENCY MOTORS / LOW VOLTAGE (200-575 v) | | | | | | | | | | | | |
| LBH | 3425 / 4211 | 1873 | 364 | 1939 | 389 | 318 | 1554 / 1910 | 850 | 165 | 880 | 176 | 144 |
| LCH | 3425 / 4211 | 1939 | 389 | 2023 | 406 | 318 | 1554 / 1910 | 880 | 176 | 918 | 184 | 144 |
| LDH | 3425 / 4211 | 2023 | 406 | 2043 | 417 | 318 | 1554 / 1910 | 918 | 184 | 927 | 189 | 144 |
| LEH | 3425 / 4211 | 2043 | 417 | 2096 | 434 | 318 | 1554 / 1910 | 927 | 189 | 951 | 197 | 144 |
| LFH | 3425 / 4211 | 2096 | 434 | 2133 | 444 | 318 | 1554 / 1910 | 951 | 197 | 968 | 201 | 144 |
| LGH | 3425 / 4211 | 2133 | 444 | 2199 | 458 | 318 | 1554 / 1910 | 968 | 201 | 997 | 208 | 144 |
| LHH | 3425 / 4211 | 2199 | 458 | 2066 | 437 | 318 | 1554 / 1910 | 997 | 208 | 937 | 198 | 144 |
| HIGH-EFFICIENCY MOTORS / MEDIUM VOLTAGE (2400-4160 v) | | | | | | | | | | | | |
| DBH | 3425 / 4211 | 1950 | 405 | 1950 | 405 | 318 | 1554 / 1910 | 885 | 184 | 885 | 184 | 144 |
| DCH | 3425 / 4211 | 1950 | 405 | 2025 | 429 | 318 | 1554 / 1910 | 885 | 184 | 919 | 195 | 144 |
| DDH | 3425 / 4211 | 1950 | 405 | 2025 | 429 | 318 | 1554 / 1910 | 885 | 184 | 919 | 195 | 144 |
| DEH | 3425 / 4211 | 2025 | 429 | 2100 | 452 | 318 | 1554 / 1910 | 919 | 195 | 953 | 205 | 144 |
| DFH | 3425 / 4211 | 2025 | 429 | 2100 | 452 | 318 | 1554 / 1910 | 919 | 195 | 953 | 205 | 144 |
| DGH | 3425 / 4211 | 2100 | 452 | 2200 | 480 | 318 | 1554 / 1910 | 953 | 205 | 998 | 218 | 144 |
| DHH | 3425 / 4211 | 2100 | 452 | 2320 | 575 | 318 | 1554 / 1910 | 953 | 205 | 1052 | 261 | 144 |
| DJH | 3425 / 4211 | 2100 | 452 | 2320 | 587 | 318 | 1554 / 1910 | 953 | 205 | 1052 | 266 | 144 |
| DKH | 3425 / 4211 | 2320 | 587 | — | — | 318 | 1554 / 1910 | 1052 | 266 | — | — | 144 |
| HIGH-EFFICIENCY MOTORS / MEDIUM VOLTAGE (6300-6900 v) | | | | | | | | | | | | |
| DDH | 3425 / 4211 | 2150 | 536 | 2250 | 546 | 318 | 1554 / 1910 | 975 | 243 | 1021 | 248 | 144 |
| DEH | 3425 / 4211 | 2150 | 550 | 2250 | 550 | 318 | 1554 / 1910 | 975 | 249 | 1021 | 249 | 144 |
| DFH | 3425 / 4211 | 2250 | 575 | 2380 | 567 | 318 | 1554 / 1910 | 1021 | 261 | 1080 | 261 | 144 |
| DGH | 3425 / 4211 | 2250 | 599 | 2380 | 599 | 318 | 1554 / 1910 | 1021 | 272 | 1080 | 272 | 144 |
| DHH | 3425 / 4211 | 2380 | 604 | 2380 | 604 | 318 | 1554 / 1910 | 1080 | 274 | 1080 | 274 | 144 |
| DJH | 3425 / 4211 | 2380 | 614 | 2380 | 614 | 318 | 1554 / 1910 | 1080 | 279 | 1080 | 279 | 144 |
| DKH | 3425 / 4211 | 2380 | 614 | — | — | 318 | 1554 / 1910 | 1080 | 279 | — | — | 144 |

*Total compressor weight is the sum of the compressor aerodynamic components (compressor weight column), stator, rotor, and end bell cover weights.

†See Model Number Nomenclature on page 7.

**Compressor aerodynamic component weight only, motor weight not included. Applicable to standard compressors only. For high lift compressors, contact Carrier Chiller Marketing for weights.

††Stator weight includes the stator and shell.

**19XR,XRV COMPRESSOR AND MOTOR WEIGHTS*—
STANDARD AND HIGH-EFFICIENCY MOTORS (cont)
COMPRESSOR FRAME SIZE 5†**

| MOTOR CODE | ENGLISH | | | | | | SI | | | | | |
|--|--------------------------|----------------------|-------------------|----------------------|-------------------|----------------------------|--------------------------|----------------------|-------------------|----------------------|-------------------|----------------------------|
| | Compressor Weight** (lb) | 60 Hz | | 50 Hz | | End Bell Cover Weight (lb) | Compressor Weight** (kg) | 60 Hz | | 50 Hz | | End Bell Cover Weight (kg) |
| | | Stator Weight†† (lb) | Rotor Weight (lb) | Stator Weight†† (lb) | Rotor Weight (lb) | | | Stator Weight†† (kg) | Rotor Weight (kg) | Stator Weight†† (kg) | Rotor Weight (kg) | |
| STANDARD-EFFICIENCY MOTORS / LOW VOLTAGE (200-575 v) | | | | | | | | | | | | |
| EHS | 7285 | 2700 | 651 | 2770 | 701 | 414 | 3304 | 1225 | 295 | 1256 | 318 | 188 |
| EJS | 7285 | 2760 | 670 | 2890 | 701 | 414 | 3304 | 1252 | 304 | 1311 | 318 | 188 |
| EKS | 7285 | 2760 | 670 | 2890 | 718 | 414 | 3304 | 1252 | 304 | 1311 | 326 | 188 |
| ELS | 7285 | 2800 | 685 | 2960 | 751 | 414 | 3304 | 1270 | 311 | 1343 | 341 | 188 |
| EMS | 7285 | 2800 | 685 | 2960 | 751 | 414 | 3304 | 1270 | 311 | 1343 | 341 | 188 |
| ENS | 7285 | 2960 | 751 | 3110 | 801 | 414 | 3304 | 1343 | 341 | 1411 | 363 | 188 |
| EPS | 7285 | 2960 | 780 | 3110 | 801 | 414 | 3304 | 1343 | 354 | 1411 | 363 | 188 |
| EQS | 7285 | 3110 | 801 | — | — | 414 | 3304 | 1411 | 363 | — | — | 188 |
| STANDARD-EFFICIENCY MOTORS / MEDIUM VOLTAGE (2400-4160 v) | | | | | | | | | | | | |
| EHS | 7285 | 2744 | 706 | 2818 | 741 | 414 | 3304 | 1245 | 320 | 1278 | 336 | 188 |
| EJS | 7285 | 2816 | 741 | 2892 | 775 | 414 | 3304 | 1277 | 336 | 1312 | 352 | 188 |
| EKS | 7285 | 2816 | 741 | 2930 | 775 | 414 | 3304 | 1277 | 336 | 1329 | 352 | 188 |
| ELS | 7285 | 2808 | 741 | 3005 | 810 | 414 | 3304 | 1274 | 336 | 1363 | 367 | 188 |
| EMS | 7285 | 2892 | 775 | 3005 | 810 | 414 | 3304 | 1322 | 352 | 1363 | 367 | 188 |
| ENS | 7285 | 2997 | 775 | 3143 | 879 | 414 | 3304 | 1359 | 352 | 1426 | 399 | 188 |
| EPS | 7285 | 2967 | 810 | 3144 | 879 | 414 | 3304 | 1346 | 367 | 1426 | 399 | 188 |
| EQS | 7285 | 3081 | 872 | — | — | 414 | 3304 | 1398 | 396 | — | — | 188 |
| STANDARD-EFFICIENCY MOTORS / MEDIUM VOLTAGE (6300-6900 v) | | | | | | | | | | | | |
| EHS | 7285 | 2773 | 735 | 2845 | 769 | 414 | 3304 | 1258 | 333 | 1290 | 349 | 188 |
| EJS | 7285 | 2855 | 769 | 2855 | 769 | 414 | 3304 | 1295 | 349 | 1295 | 349 | 188 |
| EKS | 7285 | 2919 | 803 | 2919 | 803 | 414 | 3304 | 1324 | 364 | 1324 | 364 | 188 |
| ELS | 7285 | 2908 | 803 | 3058 | 871 | 414 | 3304 | 1319 | 364 | 1387 | 395 | 188 |
| EMS | 7285 | 3029 | 854 | 3068 | 871 | 414 | 3304 | 1374 | 387 | 1392 | 395 | 188 |
| ENS | 7285 | 3023 | 854 | 3281 | 974 | 414 | 3304 | 1371 | 387 | 1488 | 442 | 188 |
| EPS | 7285 | 3068 | 871 | 3288 | 974 | 414 | 3304 | 1392 | 395 | 1491 | 442 | 188 |
| HIGH-EFFICIENCY MOTORS / LOW VOLTAGE (200-575 v) | | | | | | | | | | | | |
| EHH | 7285 | 3060 | 701 | 3120 | 751 | 414 | 3304 | 1388 | 318 | 1415 | 341 | 188 |
| EJH | 7285 | 3105 | 716 | 3250 | 751 | 414 | 3304 | 1408 | 325 | 1474 | 341 | 188 |
| EKH | 7285 | 3180 | 716 | 3250 | 768 | 414 | 3304 | 1442 | 325 | 1474 | 348 | 188 |
| ELH | 7285 | 3180 | 737 | 3370 | 801 | 414 | 3304 | 1442 | 334 | 1529 | 363 | 188 |
| EMH | 7285 | 3270 | 737 | 3370 | 801 | 414 | 3304 | 1483 | 334 | 1529 | 363 | 188 |
| ENH | 7285 | 3270 | 801 | 3520 | 851 | 414 | 3304 | 1483 | 363 | 1597 | 386 | 188 |
| EPH | 7285 | 3340 | 830 | 3520 | 851 | 414 | 3304 | 1515 | 376 | 1597 | 386 | 188 |
| EQH | 7285 | 3520 | 851 | — | — | 414 | 3304 | 1597 | 386 | — | — | 188 |

*Total compressor weight is the sum of the compressor aerodynamic components (compressor weight column), stator, rotor, and end bell cover weights.
†See Model Number Nomenclature on page 7.

**Compressor aerodynamic component weight only, motor weight not included. Applicable to standard compressors only. For high lift compressors, contact Carrier Chiller Marketing for weights.
††Stator weight includes the stator and shell.

Physical data (cont)



19XR,XRV COMPRESSOR AND MOTOR WEIGHTS*— STANDARD AND HIGH-EFFICIENCY MOTORS (cont) COMPRESSOR FRAME SIZE 5† (cont)

| MOTOR CODE | ENGLISH | | | | | | SI | | | | | |
|--|--------------------------|----------------------|-------------------|----------------------|-------------------|----------------------------|--------------------------|----------------------|-------------------|----------------------|-------------------|----------------------------|
| | Compressor Weight** (lb) | 60 Hz | | 50 Hz | | End Bell Cover Weight (lb) | Compressor Weight** (kg) | 60 Hz | | 50 Hz | | End Bell Cover Weight (kg) |
| | | Stator Weight†† (lb) | Rotor Weight (lb) | Stator Weight†† (lb) | Rotor Weight (lb) | | | Stator Weight†† (kg) | Rotor Weight (kg) | Stator Weight†† (kg) | Rotor Weight (kg) | |
| HIGH-EFFICIENCY MOTORS / LOW VOLTAGE (200-575 v) | | | | | | | | | | | | |
| MBH | 7285 | 2795 | 645 | 2856 | 665 | 414 | 3304 | 1268 | 293 | 1295 | 302 | 188 |
| MCH | 7285 | 2873 | 672 | 2925 | 693 | 414 | 3304 | 1303 | 305 | 1327 | 314 | 188 |
| MDH | 7285 | 2906 | 684 | 3013 | 724 | 414 | 3304 | 1318 | 310 | 1367 | 328 | 188 |
| MEH | 7285 | 2956 | 704 | 3071 | 737 | 414 | 3304 | 1341 | 319 | 1392 | 334 | 188 |
| MFH | 7285 | 3034 | 724 | 3153 | 791 | 414 | 3304 | 1376 | 328 | 1430 | 359 | 188 |
| MGH | 7285 | 3071 | 737 | — | — | 414 | 3304 | 1393 | 334 | — | — | 188 |
| HIGH-EFFICIENCY MOTORS / MEDIUM VOLTAGE (2400-4160 v) | | | | | | | | | | | | |
| EHH | 7285 | 2939 | 776 | 2997 | 810 | 414 | 3304 | 1333 | 352 | 1359 | 367 | 188 |
| EJH | 7285 | 2999 | 810 | 3108 | 862 | 414 | 3304 | 1360 | 367 | 1410 | 391 | 188 |
| EKH | 7285 | 2988 | 810 | 3102 | 862 | 414 | 3304 | 1355 | 367 | 1407 | 391 | 188 |
| ELH | 7285 | 2981 | 810 | 3065 | 872 | 414 | 3304 | 1352 | 367 | 1390 | 396 | 188 |
| EMH | 7285 | 3031 | 855 | 3077 | 872 | 414 | 3304 | 1375 | 388 | 1396 | 396 | 188 |
| ENH | 7285 | 3075 | 872 | 3260 | 974 | 414 | 3304 | 1395 | 396 | 1479 | 442 | 188 |
| EPH | 7285 | 3081 | 872 | 3298 | 974 | 414 | 3304 | 1398 | 396 | 1496 | 442 | 188 |
| HIGH-EFFICIENCY MOTORS / MEDIUM VOLTAGE (6300-6900 v) | | | | | | | | | | | | |
| EHH | 7285 | 2998 | 810 | 3097 | 862 | 414 | 3304 | 1360 | 367 | 1405 | 391 | 188 |
| EJH | 7285 | 3029 | 855 | 3100 | 862 | 414 | 3304 | 1374 | 388 | 1406 | 391 | 188 |
| EKH | 7285 | 3049 | 855 | 3064 | 872 | 414 | 3304 | 1383 | 388 | 1390 | 396 | 188 |
| ELH | 7285 | 3068 | 872 | 3060 | 872 | 414 | 3304 | 1390 | 396 | 1388 | 396 | 188 |
| EMH | 7285 | — | — | 3072 | 872 | 414 | 3304 | — | — | 1393 | 396 | 188 |
| ENH | 7285 | 3075 | 872 | 3260 | 974 | 414 | 3304 | 1395 | 396 | 1479 | 442 | 188 |
| EPH | 7285 | 3081 | 872 | 3288 | 974 | 414 | 3304 | 1398 | 396 | 1491 | 442 | 188 |
| HIGH-EFFICIENCY MOTORS / HIGH VOLTAGE (10000-11000 v) | | | | | | | | | | | | |
| MCH | 7285 | — | — | 3956 | 678 | 414 | 3304 | — | — | 1794 | 308 | 188 |
| MDH | 7285 | — | — | 3956 | 678 | 414 | 3304 | — | — | 1794 | 308 | 188 |
| MFH | 7285 | — | — | 4062 | 719 | 414 | 3304 | — | — | 1842 | 326 | 188 |
| MGH | 7285 | 3820 | 657 | — | — | 414 | 3304 | 1733 | 298 | — | — | 188 |
| MHH | 7285 | 3820 | 657 | — | — | 414 | 3304 | 1733 | 298 | — | — | 188 |
| HIGH-EFFICIENCY MOTORS / HIGH VOLTAGE (13800 v) | | | | | | | | | | | | |
| MHH | 7285 | 3779 | 646 | — | — | 414 | 3304 | 1714 | 293 | — | — | 188 |

*Total compressor weight is the sum of the compressor aerodynamic components (compressor weight column), stator, rotor, and end bell cover weights.

†See Model Number Nomenclature on page 7.

**Compressor aerodynamic component weight only, motor weight not included. Applicable to standard compressors only. For high lift compressors, contact Carrier Chiller Marketing for weights.

††Stator weight includes the stator and shell.

**19XR,XRV COMPRESSOR AND MOTOR WEIGHTS*—
STANDARD AND HIGH-EFFICIENCY MOTORS (cont)
COMPRESSOR FRAME SIZE E†**

| MOTOR CODE | ENGLISH | | | | | | SI | | | | | |
|--|--------------------------|----------------------|-------------------|----------------------|-------------------|----------------------------|--------------------------|----------------------|-------------------|----------------------|-------------------|----------------------------|
| | Compressor Weight** (lb) | 60 Hz | | 50 Hz | | End Bell Cover Weight (lb) | Compressor Weight** (kg) | 60 Hz | | 50 Hz | | End Bell Cover Weight (kg) |
| | | Stator Weight†† (lb) | Rotor Weight (lb) | Stator Weight†† (lb) | Rotor Weight (lb) | | | Stator Weight†† (kg) | Rotor Weight (kg) | Stator Weight†† (kg) | Rotor Weight (kg) | |
| STANDARD-EFFICIENCY MOTORS / LOW VOLTAGE (380-575 v) | | | | | | | | | | | | |
| 6H | 4853 | 2843 | 741 | 2943 | 775 | 414 | 2201 | 1290 | 336 | 1335 | 352 | 188 |
| 6J | 4853 | 2826 | 741 | 2943 | 775 | 414 | 2201 | 1281 | 336 | 1335 | 352 | 188 |
| 6K | 4853 | 2943 | 775 | 2997 | 810 | 414 | 2201 | 1335 | 352 | 1359 | 367 | 188 |
| 6L | 4853 | 2932 | 775 | 2997 | 810 | 414 | 2201 | 1330 | 352 | 1359 | 367 | 188 |
| 6M | 4853 | 2986 | 810 | 3096 | 862 | 414 | 2201 | 1354 | 367 | 1404 | 391 | 188 |
| 6N | 4853 | 2986 | 810 | 3203 | 914 | 414 | 2201 | 1354 | 367 | 1453 | 415 | 188 |
| 6P | 4853 | 2986 | 810 | 3203 | 914 | 414 | 2201 | 1354 | 367 | 1453 | 415 | 188 |
| STANDARD-EFFICIENCY MOTORS / MEDIUM VOLTAGE (2400-4160 v) | | | | | | | | | | | | |
| 6H | 4853 | 2744 | 706 | 2818 | 741 | 414 | 2201 | 1245 | 320 | 1278 | 336 | 188 |
| 6J | 4853 | 2816 | 741 | 2892 | 775 | 414 | 2201 | 1277 | 336 | 1312 | 352 | 188 |
| 6K | 4853 | 2816 | 741 | 2930 | 775 | 414 | 2201 | 1277 | 336 | 1329 | 352 | 188 |
| 6L | 4853 | 2808 | 741 | 3005 | 810 | 414 | 2201 | 1274 | 336 | 1363 | 367 | 188 |
| 6M | 4853 | 2892 | 775 | 3005 | 810 | 414 | 2201 | 1322 | 352 | 1363 | 367 | 188 |
| 6N | 4853 | 2997 | 775 | 3143 | 879 | 414 | 2201 | 1359 | 352 | 1426 | 399 | 188 |
| 6P | 4853 | 2967 | 810 | 3144 | 879 | 414 | 2201 | 1346 | 367 | 1426 | 399 | 188 |
| 6Q | 4853 | 3081 | 872 | — | — | 414 | 2201 | 1398 | 396 | — | — | 188 |
| HIGH-EFFICIENCY MOTORS / LOW VOLTAGE (380-460 v) | | | | | | | | | | | | |
| EH | 4853 | 2939 | 776 | 2995 | 810 | 414 | 2201 | 1333 | 352 | 1359 | 367 | 188 |
| EJ | 4853 | 2944 | 776 | 3002 | 810 | 414 | 2201 | 1335 | 352 | 1362 | 367 | 188 |
| EK | 4853 | 2992 | 810 | 3110 | 862 | 414 | 2201 | 1357 | 367 | 1411 | 391 | 188 |
| EL | 4853 | 2299 | 810 | 3099 | 862 | 414 | 2201 | 1043 | 367 | 1406 | 391 | 188 |
| EM | 4853 | 2965 | 810 | 3210 | 914 | 414 | 2201 | 1345 | 367 | 1456 | 415 | 188 |
| EN | 4853 | 3015 | 855 | 3293 | 974 | 414 | 2201 | 1368 | 388 | 1494 | 442 | 188 |
| EP | 4853 | 3029 | 855 | 3289 | 974 | 414 | 2201 | 1374 | 388 | 1492 | 442 | 188 |

*Total compressor weight is the sum of the compressor aerodynamic components (compressor weight column), stator, rotor, and end bell cover weights.

†See Model Number Nomenclature on page 7.

**Compressor aerodynamic component weight only, motor weight not included. Applicable to standard compressors only. For high lift compressors, contact Carrier Chiller Marketing for weights.

††Stator weight includes the stator and shell.

Physical data (cont)



19XR,XRV COMPRESSOR AND MOTOR WEIGHTS*— STANDARD AND HIGH-EFFICIENCY MOTORS (cont) COMPRESSOR FRAME SIZE E† (cont)

| MOTOR CODE | ENGLISH | | | | | | SI | | | | | |
|--|--------------------------|----------------------|-------------------|----------------------|-------------------|----------------------------|--------------------------|----------------------|-------------------|----------------------|-------------------|----------------------------|
| | Compressor Weight** (lb) | 60 Hz | | 50 Hz | | End Bell Cover Weight (lb) | Compressor Weight** (kg) | 60 Hz | | 50 Hz | | End Bell Cover Weight (kg) |
| | | Stator Weight†† (lb) | Rotor Weight (lb) | Stator Weight†† (lb) | Rotor Weight (lb) | | | Stator Weight†† (kg) | Rotor Weight (kg) | Stator Weight†† (kg) | Rotor Weight (kg) | |
| HIGH-EFFICIENCY MOTORS / LOW VOLTAGE (400-460 v) | | | | | | | | | | | | |
| MB | 4853 | 2795 | 645 | 2856 | 665 | 414 | 2201 | 1268 | 293 | 1295 | 302 | 188 |
| MC | 4853 | 2873 | 672 | 2925 | 693 | 414 | 2201 | 1303 | 305 | 1327 | 314 | 188 |
| MD | 4853 | 2906 | 684 | 3013 | 724 | 414 | 2201 | 1318 | 310 | 1367 | 328 | 188 |
| ME | 4853 | 2956 | 704 | 3071 | 737 | 414 | 2201 | 1341 | 319 | 1392 | 334 | 188 |
| MF | 4853 | 3034 | 724 | 3153 | 791 | 414 | 2201 | 1376 | 328 | 1430 | 359 | 188 |
| MG | 4853 | 3071 | 737 | — | — | 414 | 2201 | 1393 | 334 | — | — | 188 |
| HIGH-EFFICIENCY MOTORS / MEDIUM VOLTAGE (2400-4160 v) | | | | | | | | | | | | |
| EH | 4853 | 2939 | 776 | 2997 | 810 | 414 | 2201 | 1333 | 352 | 1359 | 367 | 188 |
| EJ | 4853 | 2999 | 810 | 3108 | 862 | 414 | 2201 | 1360 | 367 | 1410 | 391 | 188 |
| EK | 4853 | 2988 | 810 | 3102 | 862 | 414 | 2201 | 1355 | 367 | 1407 | 391 | 188 |
| EL | 4853 | 2981 | 810 | 3065 | 872 | 414 | 2201 | 1352 | 367 | 1390 | 396 | 188 |
| EM | 4853 | 3031 | 855 | 3077 | 872 | 414 | 2201 | 1375 | 388 | 1396 | 396 | 188 |
| EN | 4853 | 3075 | 872 | 3260 | 974 | 414 | 2201 | 1395 | 396 | 1479 | 442 | 188 |
| EP | 4853 | 3081 | 872 | 3298 | 974 | 414 | 2201 | 1398 | 396 | 1496 | 442 | 188 |
| HIGH-EFFICIENCY MOTORS / MEDIUM VOLTAGE (6300-6900 v) | | | | | | | | | | | | |
| EH | 4853 | 2998 | 810 | 3097 | 862 | 414 | 2201 | 1360 | 367 | 1405 | 391 | 188 |
| EJ | 4853 | 3029 | 855 | 3100 | 862 | 414 | 2201 | 1374 | 388 | 1406 | 391 | 188 |
| EK | 4853 | 3049 | 855 | 3064 | 872 | 414 | 2201 | 1383 | 388 | 1390 | 396 | 188 |
| EL | 4853 | 3068 | 872 | 3060 | 872 | 414 | 2201 | 1390 | 396 | 1388 | 396 | 188 |
| EM | 4853 | — | — | 3072 | 872 | 414 | 2201 | — | — | 1393 | 396 | 188 |
| EN | 4853 | 3075 | 872 | 3260 | 974 | 414 | 2201 | 1395 | 396 | 1479 | 442 | 188 |
| EP | 4853 | 3081 | 872 | 3288 | 974 | 414 | 2201 | 1398 | 396 | 1491 | 442 | 188 |
| HIGH-EFFICIENCY MOTORS / HIGH VOLTAGE (10000-11000 v) | | | | | | | | | | | | |
| MD | 4853 | — | — | 3956 | 678 | 414 | 2201 | — | — | 1794 | 308 | 188 |
| MF | 4853 | — | — | 4062 | 719 | 414 | 2201 | — | — | 1842 | 326 | 188 |
| MH | 4853 | 3820 | 657 | — | — | 414 | 2201 | 1733 | 298 | — | — | 188 |
| HIGH-EFFICIENCY MOTORS / HIGH VOLTAGE (13800 v) | | | | | | | | | | | | |
| MH | 4853 | 3779 | 646 | — | — | 414 | 2201 | 1714 | 293 | — | — | 188 |

*Total compressor weight is the sum of the compressor aerodynamic components (compressor weight column), stator, rotor, and end bell cover weights.

†See Model Number Nomenclature on page 7.

**Compressor aerodynamic component weight only, motor weight not included. Applicable to standard compressors only. For high lift compressors, contact Carrier Chiller Marketing for weights.

††Stator weight includes the stator and shell.

19XR COMPRESSOR AND MOTOR WEIGHTS*— HIGH-EFFICIENCY MOTORS
COMPRESSOR FRAME SIZE 6, 60 Hz†

| MOTOR CODE | ENGLISH | | | | SI | | | |
|----------------------------|--------------------------|--------------------------------|-----------------------------|----------------------------|--------------------------|--------------------------------|-----------------------------|----------------------------|
| | COMPRESSOR WEIGHT** (lb) | STATOR AND HOUSING WEIGHT (lb) | ROTOR AND SHAFT WEIGHT (lb) | END BELL COVER WEIGHT (lb) | COMPRESSOR WEIGHT** (kg) | STATOR AND HOUSING WEIGHT (kg) | ROTOR AND SHAFT WEIGHT (kg) | END BELL COVER WEIGHT (kg) |
| Voltage: 2400-3-60 | | | | | | | | |
| N | 10,287 | 5929 | 1212 | 1021 | 4666 | 2689 | 550 | 463 |
| P | 10,287 | 6021 | 1230 | 1021 | 4666 | 2731 | 558 | 463 |
| Q | 10,287 | 6112 | 1248 | 1021 | 4666 | 2772 | 566 | 463 |
| R | 10,287 | 6190 | 1264 | 1021 | 4666 | 2808 | 573 | 463 |
| S | 10,287 | 6268 | 1280 | 1021 | 4666 | 2843 | 581 | 463 |
| T | 10,287 | 6259 | 1280 | 1021 | 4666 | 2839 | 581 | 463 |
| Voltage: 3300-3-60 | | | | | | | | |
| N | 10,287 | 5927 | 1212 | 1021 | 4666 | 2688 | 550 | 463 |
| P | 10,287 | 6019 | 1230 | 1021 | 4666 | 2730 | 558 | 463 |
| Q | 10,287 | 6110 | 1248 | 1021 | 4666 | 2771 | 566 | 463 |
| R | 10,287 | 6187 | 1264 | 1021 | 4666 | 2806 | 573 | 463 |
| S | 10,287 | 6263 | 1280 | 1021 | 4666 | 2841 | 581 | 463 |
| T | 10,287 | 6277 | 1280 | 1021 | 4666 | 2847 | 581 | 463 |
| Voltage: 4160-3-60 | | | | | | | | |
| N | 10,287 | 6103 | 1247 | 1021 | 4666 | 2768 | 566 | 463 |
| P | 10,287 | 6103 | 1248 | 1021 | 4666 | 2768 | 566 | 463 |
| Q | 10,287 | 6103 | 1248 | 1021 | 4666 | 2768 | 566 | 463 |
| R | 10,287 | 6185 | 1264 | 1021 | 4666 | 2805 | 573 | 463 |
| S | 10,287 | 6268 | 1280 | 1021 | 4666 | 2843 | 581 | 463 |
| T | 10,287 | 6268 | 1280 | 1021 | 4666 | 2843 | 581 | 463 |
| Voltage: 6900-3-60 | | | | | | | | |
| N | 10,287 | 6558 | 1316 | 1021 | 4666 | 2975 | 600 | 463 |
| P | 10,287 | 6559 | 1316 | 1021 | 4666 | 2975 | 600 | 463 |
| Q | 10,287 | 6559 | 1316 | 1021 | 4666 | 2975 | 600 | 463 |
| R | 10,287 | 6566 | 1316 | 1021 | 4666 | 2978 | 600 | 463 |
| S | 10,287 | 6574 | 1316 | 1021 | 4666 | 2982 | 600 | 463 |
| T | 10,287 | 6604 | 1351 | 1021 | 4666 | 2996 | 613 | 463 |
| Voltage: 11000-3-60 | | | | | | | | |
| N | 10,287 | 6587 | 1351 | 1021 | 4666 | 2988 | 613 | 463 |
| P | 10,287 | 6587 | 1351 | 1021 | 4666 | 2988 | 613 | 463 |
| Q | 10,287 | 6587 | 1351 | 1021 | 4666 | 2988 | 613 | 463 |
| R | 10,287 | 6716 | 1385 | 1021 | 4666 | 3036 | 628 | 463 |
| S | 10,287 | 6844 | 1419 | 1021 | 4666 | 3104 | 644 | 463 |
| T | 10,287 | 6844 | 1419 | 1021 | 4666 | 3104 | 644 | 463 |
| Voltage: 13800-3-60 | | | | | | | | |
| N | 10,287 | 6554 | 1351 | 1021 | 4666 | 2973 | 613 | 463 |
| P | 10,287 | 6554 | 1351 | 1021 | 4666 | 2973 | 613 | 463 |
| Q | 10,287 | 6554 | 1351 | 1021 | 4666 | 2973 | 613 | 463 |
| R | 10,287 | 6709 | 1385 | 1021 | 4666 | 3043 | 628 | 463 |
| S | 10,287 | 6864 | 1419 | 1021 | 4666 | 3113 | 644 | 463 |
| T | 10,287 | 6864 | 1419 | 1021 | 4666 | 3113 | 644 | 463 |

*Total compressor weight is the sum of the compressor aerodynamic components (compressor weight column), stator, rotor, and end bell cover weights.

**Compressor aerodynamic component weight only, motor weight not included. Applicable to standard compressors only. For high lift compressors, contact Carrier Chiller Marketing for weights.

†See Model Number Nomenclature on page 8.

Physical data (cont)



19XR COMPRESSOR AND MOTOR WEIGHTS*— HIGH-EFFICIENCY MOTORS (cont) COMPRESSOR FRAME SIZE 6, 50 Hz†

| MOTOR CODE | ENGLISH | | | | SI | | | |
|----------------------------|-------------------------|--------------------------------|-----------------------------|----------------------------|-------------------------|--------------------------------|-----------------------------|----------------------------|
| | COMPRESSOR WEIGHT† (lb) | STATOR AND HOUSING WEIGHT (lb) | ROTOR AND SHAFT WEIGHT (lb) | END BELL COVER WEIGHT (lb) | COMPRESSOR WEIGHT† (kg) | STATOR AND HOUSING WEIGHT (kg) | ROTOR AND SHAFT WEIGHT (kg) | END BELL COVER WEIGHT (kg) |
| Voltage: 3000-3-50 | | | | | | | | |
| N | 10,287 | 5918 | 1212 | 1021 | 4666 | 2684 | 550 | 463 |
| P | 10,287 | 6006 | 1230 | 1021 | 4666 | 2724 | 558 | 463 |
| Q | 10,287 | 6094 | 1248 | 1021 | 4666 | 2764 | 566 | 463 |
| R | 10,287 | 6184 | 1264 | 1021 | 4666 | 2805 | 573 | 463 |
| S | 10,287 | 6274 | 1280 | 1021 | 4666 | 2846 | 581 | 463 |
| T | 10,287 | 6296 | 1280 | 1021 | 4666 | 2856 | 581 | 463 |
| Voltage: 3300-3-50 | | | | | | | | |
| N | 10,287 | 5913 | 1212 | 1021 | 4666 | 2682 | 550 | 463 |
| P | 10,287 | 6007 | 1230 | 1021 | 4666 | 2725 | 558 | 463 |
| Q | 10,287 | 6101 | 1248 | 1021 | 4666 | 2767 | 566 | 463 |
| R | 10,287 | 6192 | 1264 | 1021 | 4666 | 2809 | 573 | 463 |
| S | 10,287 | 6283 | 1280 | 1021 | 4666 | 2850 | 581 | 463 |
| T | 10,287 | 6266 | 1280 | 1021 | 4666 | 2842 | 581 | 463 |
| Voltage: 6300-3-50 | | | | | | | | |
| N | 10,287 | 6277 | 1280 | 1021 | 4666 | 2847 | 581 | 463 |
| P | 10,287 | 6333 | 1298 | 1021 | 4666 | 2873 | 589 | 463 |
| Q | 10,287 | 6389 | 1316 | 1021 | 4666 | 2898 | 600 | 463 |
| R | 10,287 | 6473 | 1316 | 1021 | 4666 | 2936 | 600 | 463 |
| S | 10,287 | 6556 | 1316 | 1021 | 4666 | 2974 | 600 | 463 |
| T | 10,287 | 6609 | 1351 | 1021 | 4666 | 2998 | 613 | 463 |
| Voltage: 10000-3-50 | | | | | | | | |
| N | 10,287 | 6281 | 1280 | 1021 | 4666 | 2849 | 581 | 463 |
| P | 10,287 | 6281 | 1281 | 1021 | 4666 | 2849 | 581 | 463 |
| Q | 10,287 | 6281 | 1281 | 1021 | 4666 | 2849 | 581 | 463 |
| R | 10,287 | 6441 | 1316 | 1021 | 4666 | 2922 | 600 | 463 |
| S | 10,287 | 6600 | 1351 | 1021 | 4666 | 2994 | 613 | 463 |
| T | 10,287 | 6156 | 1351 | 1021 | 4666 | 2792 | 613 | 463 |
| Voltage: 11000-3-50 | | | | | | | | |
| N | 10,287 | 6600 | 1351 | 1021 | 4666 | 2994 | 613 | 463 |
| P | 10,287 | 6600 | 1351 | 1021 | 4666 | 2994 | 613 | 463 |
| Q | 10,287 | 6600 | 1351 | 1021 | 4666 | 2994 | 613 | 463 |
| R | 10,287 | 6765 | 1385 | 1021 | 4666 | 3069 | 628 | 463 |
| S | 10,287 | 6930 | 1419 | 1021 | 4666 | 3143 | 644 | 463 |
| T | 10,287 | 6930 | 1419 | 1021 | 4666 | 3143 | 644 | 463 |

*Total compressor weight is the sum of the compressor aerodynamic components (compressor weight column), stator, rotor, and end bell cover weights.

†See Model Number Nomenclature on page 8.

**Compressor aerodynamic component weight only, motor weight not included. Applicable to standard compressors only. For high lift compressors, contact Carrier Chiller Marketing for weights.

19XR COMPRESSOR AND MOTOR WEIGHTS*— HIGH-EFFICIENCY MOTORS (cont)
COMPRESSOR FRAME SIZE 7, 60 Hz†

| MOTOR CODE | ENGLISH | | | | SI | | | |
|----------------------------|--------------------------|--------------------------------|-----------------------------|----------------------------|--------------------------|--------------------------------|-----------------------------|----------------------------|
| | COMPRESSOR WEIGHT** (lb) | STATOR AND HOUSING WEIGHT (lb) | ROTOR AND SHAFT WEIGHT (lb) | END BELL COVER WEIGHT (lb) | COMPRESSOR WEIGHT** (kg) | STATOR AND HOUSING WEIGHT (kg) | ROTOR AND SHAFT WEIGHT (kg) | END BELL COVER WEIGHT (kg) |
| Voltage: 2400-3-60 | | | | | | | | |
| U | 16,024 | 6719 | 1443 | 983 | 7268 | 3048 | 654 | 446 |
| V | 16,024 | 6718 | 1443 | 983 | 7268 | 3047 | 654 | 446 |
| W | 16,024 | 6717 | 1443 | 983 | 7268 | 3047 | 654 | 446 |
| X | 16,024 | 6811 | 1460 | 983 | 7268 | 3089 | 662 | 446 |
| Y | 16,024 | 6906 | 1476 | 983 | 7268 | 3132 | 670 | 446 |
| Z | 16,024 | 7073 | 1509 | 983 | 7268 | 3208 | 684 | 446 |
| Voltage: 3300-3-60 | | | | | | | | |
| U | 16,024 | 6723 | 1443 | 983 | 7268 | 3049 | 654 | 446 |
| V | 16,024 | 6730 | 1443 | 983 | 7268 | 3053 | 654 | 446 |
| W | 16,024 | 6736 | 1443 | 983 | 7268 | 3055 | 654 | 446 |
| X | 16,024 | 6816 | 1460 | 983 | 7268 | 3092 | 662 | 446 |
| Y | 16,024 | 6895 | 1476 | 983 | 7268 | 3128 | 670 | 446 |
| Z | 16,024 | 7055 | 1509 | 983 | 7268 | 3200 | 684 | 446 |
| Voltage: 4160-3-60 | | | | | | | | |
| U | 16,024 | 6739 | 1443 | 983 | 7268 | 3057 | 654 | 446 |
| V | 16,024 | 6721 | 1443 | 983 | 7268 | 3049 | 654 | 446 |
| W | 16,024 | 6703 | 1443 | 983 | 7268 | 3040 | 654 | 446 |
| X | 16,024 | 6778 | 1460 | 983 | 7268 | 3074 | 662 | 446 |
| Y | 16,024 | 6853 | 1476 | 983 | 7268 | 3108 | 670 | 446 |
| Z | 16,024 | 7069 | 1509 | 983 | 7268 | 3206 | 684 | 446 |
| Voltage: 6900-3-60 | | | | | | | | |
| U | 16,024 | 6730 | 1443 | 983 | 7268 | 3053 | 654 | 446 |
| V | 16,024 | 6909 | 1476 | 983 | 7268 | 3134 | 670 | 446 |
| W | 16,024 | 7088 | 1509 | 983 | 7268 | 3215 | 684 | 446 |
| X | 16,024 | 7076 | 1509 | 983 | 7268 | 3210 | 684 | 446 |
| Y | 16,024 | 7064 | 1509 | 983 | 7268 | 3204 | 684 | 446 |
| Z | 16,024 | 7141 | 1542 | 983 | 7268 | 3239 | 699 | 446 |
| Voltage: 11000-3-60 | | | | | | | | |
| U | 16,024 | 7042 | 1509 | 983 | 7268 | 3194 | 684 | 446 |
| V | 16,024 | 7085 | 1526 | 983 | 7268 | 3214 | 692 | 446 |
| W | 16,024 | 7128 | 1542 | 983 | 7268 | 3233 | 699 | 446 |
| X | 16,024 | 7131 | 1542 | 983 | 7268 | 3235 | 699 | 446 |
| Y | 16,024 | 7135 | 1542 | 983 | 7268 | 3236 | 699 | 446 |
| Z | 16,024 | 7313 | 1575 | 983 | 7268 | 3317 | 714 | 446 |
| Voltage: 13800-3-60 | | | | | | | | |
| U | 16,024 | 7073 | 1509 | 983 | 7268 | 3208 | 684 | 446 |
| V | 16,024 | 7109 | 1526 | 983 | 7268 | 3225 | 692 | 446 |
| W | 16,024 | 7146 | 1542 | 983 | 7268 | 3241 | 699 | 446 |
| X | 16,024 | 7146 | 1542 | 983 | 7268 | 3241 | 699 | 446 |
| Y | 16,024 | 7146 | 1542 | 983 | 7268 | 3241 | 699 | 446 |
| Z | 16,024 | 7295 | 1575 | 983 | 7268 | 3309 | 714 | 446 |

*Total compressor weight is the sum of the compressor aerodynamic components (compressor weight column), stator, rotor, and end bell cover weights.

†See Model Number Nomenclature on page 8.

**Compressor aerodynamic component weight only, motor weight not included. Applicable to standard compressors only. For high lift compressors, contact Carrier Chiller Marketing for weights.

Physical data (cont)



19XR COMPRESSOR AND MOTOR WEIGHTS*— HIGH-EFFICIENCY MOTORS (cont) COMPRESSOR FRAME SIZE 7, 50 Hz†

| MOTOR CODE | ENGLISH | | | | SI | | | |
|----------------------------|--------------------------|--------------------------------|-----------------------------|----------------------------|--------------------------|--------------------------------|-----------------------------|----------------------------|
| | COMPRESSOR WEIGHT** (lb) | STATOR AND HOUSING WEIGHT (lb) | ROTOR AND SHAFT WEIGHT (lb) | END BELL COVER WEIGHT (lb) | COMPRESSOR WEIGHT** (kg) | STATOR AND HOUSING WEIGHT (kg) | ROTOR AND SHAFT WEIGHT (kg) | END BELL COVER WEIGHT (kg) |
| Voltage: 3000-3-50 | | | | | | | | |
| U | 16,024 | 6725 | 1443 | 983 | 7268 | 3050 | 654 | 446 |
| V | 16,024 | 6716 | 1443 | 983 | 7268 | 3046 | 654 | 446 |
| W | 16,024 | 6706 | 1443 | 983 | 7268 | 3042 | 654 | 446 |
| X | 16,024 | 6802 | 1460 | 983 | 7268 | 3085 | 662 | 446 |
| Y | 16,024 | 6899 | 1476 | 983 | 7268 | 3129 | 670 | 446 |
| Z | 16,024 | 7066 | 1509 | 983 | 7268 | 3205 | 684 | 446 |
| Voltage: 3300-3-50 | | | | | | | | |
| U | 16,024 | 6743 | 1443 | 983 | 7268 | 3059 | 654 | 446 |
| V | 16,024 | 6739 | 1443 | 983 | 7268 | 3057 | 654 | 446 |
| W | 16,024 | 6734 | 1443 | 983 | 7268 | 3054 | 654 | 446 |
| X | 16,024 | 6826 | 1460 | 983 | 7268 | 3096 | 662 | 446 |
| Y | 16,024 | 6917 | 1476 | 983 | 7268 | 3137 | 670 | 446 |
| Z | 16,024 | 7075 | 1509 | 983 | 7268 | 3209 | 684 | 446 |
| Voltage: 6300-3-50 | | | | | | | | |
| U | 16,024 | 6743 | 1443 | 983 | 7268 | 3059 | 654 | 446 |
| V | 16,024 | 6900 | 1476 | 983 | 7268 | 3130 | 670 | 446 |
| W | 16,024 | 7058 | 1509 | 983 | 7268 | 3201 | 684 | 446 |
| X | 16,024 | 7130 | 1526 | 983 | 7268 | 3234 | 692 | 446 |
| Y | 16,024 | 7203 | 1542 | 983 | 7268 | 3267 | 699 | 446 |
| Z | 16,024 | 7203 | 1542 | 983 | 7268 | 3267 | 699 | 446 |
| Voltage: 10000-3-50 | | | | | | | | |
| U | 16,024 | 6904 | 1476 | 983 | 7268 | 3132 | 670 | 446 |
| V | 16,024 | 6907 | 1476 | 983 | 7268 | 3133 | 670 | 446 |
| W | 16,024 | 6910 | 1476 | 983 | 7268 | 3134 | 670 | 446 |
| X | 16,024 | 7074 | 1509 | 983 | 7268 | 3209 | 684 | 446 |
| Y | 16,024 | 7238 | 1542 | 983 | 7268 | 3283 | 699 | 446 |
| Z | 16,024 | 7401 | 1575 | 983 | 7268 | 3357 | 714 | 446 |
| Voltage: 11000-3-50 | | | | | | | | |
| U | 16,024 | 7139 | 1509 | 983 | 7268 | 3238 | 684 | 446 |
| V | 16,024 | 7186 | 1526 | 983 | 7268 | 3260 | 692 | 446 |
| W | 16,024 | 7234 | 1542 | 983 | 7268 | 3281 | 699 | 446 |
| X | 16,024 | 7234 | 1542 | 983 | 7268 | 3281 | 699 | 446 |
| Y | 16,024 | 7234 | 1542 | 983 | 7268 | 3281 | 699 | 446 |
| Z | 16,024 | 7383 | 1575 | 983 | 7268 | 3349 | 714 | 446 |

*Total compressor weight is the sum of the compressor aerodynamic components (compressor weight column), stator, rotor, and end bell cover weights.

†See Model Number Nomenclature on page 8.

**Compressor aerodynamic component weight only, motor weight not included. Applicable to standard compressors only. For high lift compressors, contact Carrier Chiller Marketing for weights.

COMPONENT WEIGHTS — SINGLE-STAGE COMPRESSORS AND TWO-STAGE COMPRESSORS FRAME 6, FRAME 7, AND FRAME E

| COMPONENT | FRAME 2 COMPRESSOR* | | FRAME 3 COMPRESSOR* | | FRAME 4 COMPRESSOR* | | FRAME 5 COMPRESSOR* | | FRAME E COMPRESSOR* | | FRAME 6 COMPRESSOR* | | FRAME 7 COMPRESSOR* | |
|---|---------------------|-----|---------------------|-----|---------------------|------|---------------------|------|---------------------|------|---------------------|-----|---------------------|-----|
| | lb | kg | lb | kg | lb | kg | lb | kg | lb | kg | lb | kg | lb | kg |
| Suction Pipe Assembly (includes Flanges) | 116 | 53 | 185 | 84 | 239 | 108 | 407 | 185 | 310 | 141 | 486 | 220 | 613 | 278 |
| Discharge Assembly | 100 | 45 | 125 | 57 | 157 | 71 | 325 | 147 | 290 | 132 | 256 | 116 | 312 | 142 |
| Control Panel† (Frames 2-5, E) | 34 | 15 | 34 | 15 | 34 | 15 | 34 | 15 | 34 | 15 | — | — | — | — |
| Optional Cooler Inlet Isolation Valve | 8 | 4 | 13 | 6 | 20 | 9 | 24 | 11 | 24 | 11 | 26 | 12 | 28 | 13 |
| Optional Discharge Isolation Valve | 26 | 12 | 46 | 21 | 74 | 34 | 108 | 49 | 93 | 42 | 277 | 91 | 324 | 147 |
| Std Tier VFD — 380, 400, and 460-v (230, 335, 445 A) | 650 | 295 | 650 | 295 | — | — | — | — | — | — | — | — | — | — |
| Std Tier VFD — 380, 400, and 460-v (485, 550 A) | — | — | 1035 | 469 | 1035 | 469 | — | — | — | — | — | — | — | — |
| Std Tier VFD — 380, 400, and 460-v (605, 680 A) | — | — | 1600 | 726 | 1600 | 726 | — | — | — | — | — | — | — | — |
| Std Tier VFD — 380, 400, and 460-v (765 A) | — | — | — | — | 1600 | 726 | — | — | — | — | — | — | — | — |
| Std Tier VFD — 380, 400, and 460-v (855, 960, 1070 A) | — | — | — | — | 1600 | 726 | 1600 | 726 | 1600 | 726 | — | — | — | — |
| Std Tier VFD — 380, 400, and 460-v (1275 A) | — | — | — | — | 3000 | 1361 | 3000 | 1361 | 3000 | 1361 | — | — | — | — |
| Std Tier VFD — 380, 400, and 460-v (1530 A) | — | — | — | — | — | — | 3000 | 1361 | 3000 | 1361 | — | — | — | — |
| LiquiFlo™ 2 VFD — 380, 400, and 460-v (442 A) | 1600 | 726 | 1600 | 726 | — | — | — | — | — | — | — | — | — | — |
| LiquiFlo 2 VFD — 380, 400, and 460-v (608 A) | — | — | 1600 | 726 | 1600 | 726 | — | — | — | — | — | — | — | — |
| LiquiFlo 2 VFD — 380, 400, and 460-v (900 A) | — | — | — | — | 2800 | 1270 | 2800 | 1270 | 2800 | 1270 | — | — | — | — |
| LiquiFlo 2 VFD — 380, 400, and 460-v (1200 A) | — | — | — | — | 2850 | 1293 | 2850 | 1293 | 2850 | 1293 | — | — | — | — |
| LiquiFlo 2 VFD — 575-v (390 A) | 2200 | 998 | 2200 | 998 | — | — | — | — | — | — | — | — | — | — |
| VFD Shelf | — | — | — | — | 1049 | 476 | 1049 | 476 | 1049 | 476 | — | — | — | — |
| HMI Panel (Frames 6 and 7 only) | — | — | — | — | — | — | — | — | — | — | 25 | 11 | 25 | 11 |
| Auxiliary Control Panel (Frames 6 and 7 only) | — | — | — | — | — | — | — | — | — | — | 190 | 86 | 190 | 86 |
| Economizer Cover | — | — | — | — | — | — | — | — | 120 | 54 | 132 | 60 | 182 | 83 |
| High Side Float Chamber Cover | — | — | — | — | — | — | — | — | 296 | 134 | 132 | 60 | 182 | 83 |

*To determine compressor frame size, refer to 19XR,XRV Computer Selection Program.

†Included in total cooler weight.

NOTE: VFD sizes are available on select heat exchanger models; consult the 19XR,XRV Computer Selection program.

Physical data (cont)



19XR,XRV HEAT EXCHANGER WEIGHTS — SINGLE-STAGE COMPRESSOR AND TWO-STAGE COMPRESSOR FRAME SIZE E — DRIVE END ENTERING COOLER WATER

| CODE† | ENGLISH | | | | | | SI | | | | | |
|-------|--------------------------|----------------|-------------------------|-----------|-------------------|-----------|--------------------------|----------------|-------------------------|-----------|-------------------|-----------|
| | Dry Rigging Weight (lb)* | | Machine Charge | | | | Dry Rigging Weight (kg)* | | Machine Charge | | | |
| | Cooler Only | Condenser Only | Refrigerant Weight (lb) | | Water Weight (lb) | | Cooler Only | Condenser Only | Refrigerant Weight (kg) | | Water Weight (kg) | |
| | | | Cooler | Condenser | Cooler | Condenser | | | Cooler | Condenser | Cooler | Condenser |
| 10 | 2707 | 2704 | 328 | 226 | 283 | 348 | 1229 | 1228 | 149 | 103 | 128 | 158 |
| 11 | 2777 | 2772 | 357 | 226 | 309 | 374 | 1261 | 1258 | 162 | 103 | 140 | 170 |
| 12 | 2848 | 2857 | 387 | 226 | 335 | 407 | 1293 | 1297 | 176 | 103 | 152 | 185 |
| 15 | 2968 | 2984 | 405 | 275 | 327 | 402 | 1346 | 1355 | 184 | 125 | 148 | 183 |
| 16 | 3054 | 3068 | 441 | 275 | 359 | 435 | 1387 | 1393 | 200 | 125 | 163 | 197 |
| 17 | 3141 | 3173 | 477 | 275 | 391 | 475 | 1426 | 1441 | 217 | 125 | 178 | 216 |
| 20 | 3407 | 3373 | 416 | 252 | 402 | 398 | 1547 | 1531 | 189 | 114 | 183 | 181 |
| 21 | 3555 | 3540 | 459 | 252 | 456 | 462 | 1614 | 1607 | 208 | 114 | 207 | 210 |
| 22 | 3711 | 3704 | 505 | 252 | 514 | 526 | 1685 | 1682 | 229 | 114 | 233 | 239 |
| 30 | 4071 | 3694 | 510 | 308 | 464 | 464 | 1848 | 1677 | 232 | 140 | 211 | 211 |
| 31 | 4253 | 3899 | 565 | 308 | 531 | 543 | 1931 | 1770 | 257 | 140 | 241 | 247 |
| 32 | 4445 | 4100 | 626 | 308 | 601 | 621 | 2018 | 1861 | 284 | 140 | 273 | 282 |
| 35 | 4343 | 4606 | 577 | 349 | 511 | 513 | 1972 | 2091 | 262 | 158 | 232 | 233 |
| 36 | 4551 | 4840 | 639 | 349 | 587 | 603 | 2066 | 2197 | 290 | 158 | 266 | 274 |
| 37 | 4769 | 5069 | 709 | 349 | 667 | 692 | 2165 | 2301 | 322 | 158 | 303 | 314 |
| 40 | 4908 | 5039 | 726 | 338 | 863 | 915 | 2228 | 2288 | 330 | 153 | 392 | 415 |
| 41 | 5078 | 5232 | 783 | 338 | 930 | 995 | 2305 | 2375 | 355 | 153 | 422 | 452 |
| 42 | 5226 | 5424 | 840 | 338 | 990 | 1074 | 2373 | 2462 | 381 | 153 | 449 | 488 |
| 45 | 5363 | 5602 | 821 | 383 | 938 | 998 | 2435 | 2543 | 373 | 174 | 426 | 453 |
| 46 | 5559 | 5824 | 874 | 383 | 1014 | 1088 | 2524 | 2644 | 397 | 174 | 460 | 494 |
| 47 | 5730 | 6044 | 949 | 383 | 1083 | 1179 | 2601 | 2744 | 431 | 174 | 492 | 535 |
| 50 | 5713 | 6090 | 897 | 446 | 1101 | 1225 | 2594 | 2765 | 407 | 202 | 500 | 556 |
| 51 | 5940 | 6283 | 974 | 446 | 1192 | 1304 | 2697 | 2852 | 442 | 202 | 541 | 592 |
| 52 | 6083 | 6464 | 1021 | 446 | 1248 | 1379 | 2762 | 2935 | 464 | 202 | 567 | 626 |
| 53 | 6141 | 6529 | 1010 | 446 | 1277 | 1409 | 2788 | 2964 | 459 | 202 | 580 | 640 |
| 54 | 6192 | 6591 | 987 | 446 | 1302 | 1439 | 2811 | 2992 | 448 | 202 | 591 | 653 |
| 55 | 6257 | 6785 | 1014 | 504 | 1201 | 1339 | 2841 | 3080 | 460 | 229 | 545 | 608 |
| 56 | 6517 | 7007 | 1101 | 504 | 1304 | 1429 | 2959 | 3181 | 500 | 229 | 592 | 649 |
| 57 | 6682 | 7215 | 1154 | 504 | 1369 | 1514 | 3034 | 3276 | 524 | 229 | 622 | 687 |
| 58 | 6751 | 7291 | 1143 | 504 | 1401 | 1550 | 3065 | 3310 | 519 | 229 | 636 | 704 |
| 59 | 6811 | 7363 | 1116 | 504 | 1430 | 1583 | 3092 | 3343 | 507 | 229 | 649 | 719 |
| 5A | 5124 | — | 491 | — | 1023 | — | 2326 | — | 223 | — | 464 | — |
| 5B | 5177 | — | 510 | — | 1050 | — | 2350 | — | 232 | — | 477 | — |
| 5C | 5243 | — | 532 | — | 1079 | — | 2380 | — | 242 | — | 490 | — |
| 5F | 5577 | — | 553 | — | 1113 | — | 2532 | — | 251 | — | 505 | — |
| 5G | 5640 | — | 575 | — | 1143 | — | 2561 | — | 261 | — | 519 | — |
| 5H | 5716 | — | 600 | — | 1176 | — | 2595 | — | 272 | — | 534 | — |
| 5K | 4993 | — | 673 | — | 1067 | — | 2267 | — | 306 | — | 484 | — |
| 5L | 5090 | — | 706 | — | 1118 | — | 2311 | — | 321 | — | 508 | — |
| 5M | 5165 | — | 742 | — | 1162 | — | 2345 | — | 337 | — | 528 | — |
| 5P | 5041 | — | 641 | — | 1111 | — | 2289 | — | 291 | — | 504 | — |
| 5Q | 5131 | — | 678 | — | 1155 | — | 2329 | — | 308 | — | 524 | — |
| 5R | 5214 | — | 709 | — | 1206 | — | 2367 | — | 322 | — | 548 | — |
| 5T | 5425 | — | 768 | — | 1162 | — | 2463 | — | 349 | — | 528 | — |
| 5U | 5534 | — | 801 | — | 1220 | — | 2512 | — | 364 | — | 554 | — |
| 5V | 5620 | — | 843 | — | 1270 | — | 2551 | — | 383 | — | 577 | — |
| 5X | 5484 | — | 730 | — | 1212 | — | 2490 | — | 331 | — | 550 | — |
| 5Y | 5584 | — | 769 | — | 1262 | — | 2535 | — | 349 | — | 573 | — |
| 5Z | 5678 | — | 805 | — | 1320 | — | 2578 | — | 365 | — | 599 | — |
| 60 | 6719 | 6764 | 1091 | 479 | 1400 | 1521 | 3050 | 3071 | 495 | 217 | 636 | 691 |
| 61 | 6895 | 6949 | 1150 | 479 | 1470 | 1597 | 3130 | 3155 | 522 | 217 | 667 | 725 |
| 62 | 7038 | 7130 | 1202 | 479 | 1527 | 1671 | 3195 | 3237 | 546 | 217 | 693 | 759 |
| 63 | 7103 | 7199 | 1202 | 479 | 1559 | 1704 | 3225 | 3268 | 546 | 217 | 708 | 774 |
| 64 | 7161 | 7264 | 1178 | 479 | 1587 | 1735 | 3251 | 3298 | 535 | 217 | 720 | 788 |
| 65 | 7392 | 6782 | 1241 | 542 | 1530 | 1667 | 3356 | 3079 | 563 | 246 | 695 | 757 |
| 66 | 7594 | 7894 | 1309 | 542 | 1610 | 1753 | 3448 | 3584 | 594 | 246 | 731 | 796 |
| 67 | 7759 | 8102 | 1369 | 542 | 1674 | 1838 | 3523 | 3678 | 622 | 246 | 760 | 834 |
| 68 | 7836 | 8182 | 1359 | 542 | 1711 | 1875 | 3558 | 3715 | 617 | 246 | 777 | 851 |
| 69 | 7905 | 8258 | 1332 | 542 | 1743 | 1911 | 3589 | 3749 | 605 | 246 | 791 | 868 |

*Rigging weights are for standard tubes of standard wall thickness (0.025-in. [0.635 mm] wall).

†Heat exchanger frame sizes 1 through 6 available on single-stage chillers only.

NOTES:

1. Cooler includes the control panel (ICVC), suction elbow, and 1/2 the distribution piping weight.

2. Condenser includes float valve and sump, discharge elbow, and 1/2 the distribution piping weight.
3. For special tubes refer to the 19XR,XRV Computer Selection Program.
4. All weights for standard 2-pass NIH (nozzle-in-head) design.
5. For "E" compressor, add 1054 lb (478 kg) steel weight and 283 lb (128 kg) refrigerant weight for economizer assembly.

19XR,XRV HEAT EXCHANGER WEIGHTS — SINGLE-STAGE COMPRESSOR AND TWO-STAGE COMPRESSOR FRAME SIZE E — DRIVE END ENTERING COOLER WATER (cont)

| CODE† | ENGLISH | | | | | | SI | | | | | |
|-------|--------------------------|----------------|-------------------------|-----------|-------------------|-----------|--------------------------|----------------|-------------------------|-----------|-------------------|-----------|
| | Dry Rigging Weight (lb)* | | Machine Charge | | | | Dry Rigging Weight (kg)* | | Machine Charge | | | |
| | Cooler Only | Condenser Only | Refrigerant Weight (lb) | | Water Weight (lb) | | Cooler Only | Condenser Only | Refrigerant Weight (kg) | | Water Weight (kg) | |
| | | | Cooler | Condenser | Cooler | Condenser | | | Cooler | Condenser | Cooler | Condenser |
| 6K | 5,716 | — | 760 | — | 1291 | — | 2595 | — | 345 | — | 586 | — |
| 6L | 5,804 | — | 797 | — | 1341 | — | 2635 | — | 362 | — | 609 | — |
| 6M | 5,894 | — | 828 | — | 1399 | — | 2676 | — | 376 | — | 635 | — |
| 6P | 5,768 | — | 725 | — | 1338 | — | 2619 | — | 329 | — | 607 | — |
| 6Q | 5,852 | — | 764 | — | 1385 | — | 2657 | — | 347 | — | 629 | — |
| 6R | 5,938 | — | 798 | — | 1439 | — | 2696 | — | 362 | — | 653 | — |
| 6T | 6,230 | — | 863 | — | 1405 | — | 2828 | — | 392 | — | 638 | — |
| 6U | 6,330 | — | 905 | — | 1462 | — | 2874 | — | 411 | — | 664 | — |
| 6V | 6,433 | — | 941 | — | 1528 | — | 2921 | — | 427 | — | 694 | — |
| 6X | 6,293 | — | 823 | — | 1459 | — | 2857 | — | 374 | — | 662 | — |
| 6Y | 6,388 | — | 868 | — | 1512 | — | 2900 | — | 394 | — | 686 | — |
| 6Z | 6,487 | — | 906 | — | 1574 | — | 2945 | — | 411 | — | 715 | — |
| 70 | 9,942 | 10,786 | 1409 | 840 | 2008 | 2225 | 4514 | 4897 | 640 | 381 | 912 | 1010 |
| 71 | 10,330 | 11,211 | 1539 | 840 | 2164 | 2389 | 4690 | 5090 | 699 | 381 | 982 | 1085 |
| 72 | 10,632 | 11,622 | 1646 | 840 | 2286 | 2548 | 4827 | 5276 | 747 | 381 | 1038 | 1157 |
| 73 | 10,715 | 11,737 | 1622 | 840 | 2328 | 2604 | 4865 | 5329 | 736 | 381 | 1057 | 1182 |
| 74 | 10,790 | 11,775 | 1584 | 840 | 2366 | 2622 | 4899 | 5346 | 719 | 381 | 1074 | 1190 |
| 75 | 10,840 | 11,859 | 1599 | 950 | 2183 | 2431 | 4921 | 5384 | 726 | 431 | 991 | 1104 |
| 76 | 11,289 | 12,345 | 1747 | 950 | 2361 | 2619 | 5125 | 5605 | 793 | 431 | 1072 | 1189 |
| 77 | 11,638 | 12,814 | 1869 | 950 | 2501 | 2801 | 5284 | 5818 | 849 | 431 | 1135 | 1272 |
| 78 | 11,738 | 12,949 | 1849 | 950 | 2548 | 2864 | 5329 | 5879 | 839 | 431 | 1157 | 1300 |
| 79 | 11,828 | 12,994 | 1806 | 950 | 2592 | 2885 | 5370 | 5899 | 820 | 431 | 1177 | 1310 |
| 7K | 8,728 | — | 1047 | — | 1948 | — | 3963 | — | 475 | — | 884 | — |
| 7L | 8,959 | — | 1132 | — | 2094 | — | 4067 | — | 514 | — | 951 | — |
| 7M | 9,161 | — | 1214 | — | 2229 | — | 4159 | — | 551 | — | 1012 | — |
| 7P | 8,792 | — | 1002 | — | 2010 | — | 3992 | — | 455 | — | 913 | — |
| 7Q | 9,023 | — | 1087 | — | 2156 | — | 4096 | — | 493 | — | 979 | — |
| 7R | 9,229 | — | 1167 | — | 2295 | — | 4190 | — | 530 | — | 1042 | — |
| 7T | 9,431 | — | 1194 | — | 2115 | — | 4282 | — | 542 | — | 960 | — |
| 7U | 9,698 | — | 1292 | — | 2282 | — | 4403 | — | 587 | — | 1036 | — |
| 7V | 9,932 | — | 1403 | — | 2436 | — | 4509 | — | 637 | — | 1106 | — |
| 7X | 9,510 | — | 1142 | — | 2185 | — | 4318 | — | 518 | — | 992 | — |
| 7Y | 9,777 | — | 1240 | — | 2352 | — | 4439 | — | 563 | — | 1068 | — |
| 7Z | 10,016 | — | 1347 | — | 2511 | — | 4547 | — | 612 | — | 1140 | — |
| 80 | 12,664 | 12,753 | 1700 | 836 | 2726 | 2977 | 5749 | 5790 | 772 | 380 | 1238 | 1352 |
| 81 | 12,998 | 13,149 | 1812 | 836 | 2863 | 3143 | 5901 | 5970 | 823 | 380 | 1300 | 1427 |
| 82 | 13,347 | 13,545 | 1928 | 836 | 3005 | 3309 | 6060 | 6149 | 875 | 380 | 1364 | 1502 |
| 83 | 13,437 | 13,872 | 1877 | 836 | 3053 | 3476 | 6100 | 6298 | 852 | 380 | 1386 | 1578 |
| 84 | 13,523 | 14,217 | 1840 | 836 | 3099 | 3651 | 6139 | 6455 | 835 | 380 | 1407 | 1658 |
| 85 | 13,804 | 14,008 | 1927 | 945 | 2951 | 3238 | 6267 | 6360 | 875 | 429 | 1340 | 1470 |
| 86 | 14,191 | 14,465 | 2054 | 945 | 3108 | 3428 | 6443 | 6567 | 933 | 429 | 1411 | 1556 |
| 87 | 14,597 | 14,923 | 2186 | 945 | 3271 | 3618 | 6627 | 6775 | 992 | 429 | 1485 | 1643 |
| 88 | 14,705 | 15,311 | 2142 | 945 | 3325 | 3608 | 6676 | 6951 | 972 | 429 | 1510 | 1638 |
| 89 | 14,808 | 15,721 | 2099 | 945 | 3378 | 4009 | 6723 | 7137 | 953 | 429 | 1534 | 1820 |
| 8K | 11,153 | — | 1385 | — | 2760 | — | 5063 | — | 629 | — | 1253 | — |
| 8L | 11,400 | — | 1484 | — | 2926 | — | 5176 | — | 674 | — | 1328 | — |
| 8M | 11,650 | — | 1589 | — | 3088 | — | 5289 | — | 721 | — | 1402 | — |
| 8P | 11,219 | — | 1334 | — | 2830 | — | 5093 | — | 606 | — | 1285 | — |
| 8Q | 11,470 | — | 1430 | — | 2999 | — | 5207 | — | 649 | — | 1362 | — |
| 8R | 11,719 | — | 1535 | — | 3161 | — | 5320 | — | 697 | — | 1435 | — |
| 8T | 12,069 | — | 1580 | — | 2991 | — | 5479 | — | 717 | — | 1358 | — |
| 8U | 12,357 | — | 1694 | — | 3180 | — | 5610 | — | 769 | — | 1444 | — |
| 8V | 12,645 | — | 1814 | — | 3365 | — | 5741 | — | 824 | — | 1528 | — |
| 8X | 12,152 | — | 1522 | — | 3070 | — | 5517 | — | 691 | — | 1394 | — |
| 8Y | 12,444 | — | 1632 | — | 3264 | — | 5650 | — | 741 | — | 1482 | — |
| 8Z | 12,733 | — | 1752 | — | 3448 | — | 5781 | — | 795 | — | 1565 | — |

*Rigging weights are for standard tubes of standard wall thickness (0.025-in. [0.635 mm] wall).

†Heat exchanger frame sizes 1 through 6 available on single-stage chillers only.

NOTES:

1. Cooler includes the control panel (ICVC), suction elbow, and 1/2 the distribution piping weight.

2. Condenser includes float valve and sump, discharge elbow, and 1/2 the distribution piping weight.

3. For special tubes refer to the 19XR,XRV Computer Selection Program.

4. All weights for standard 2-pass NIH (nozzle-in-head) design.

5. For "E" compressor, add 1054 lb (478 kg) steel weight and 283 lb (128 kg) refrigerant weight for economizer assembly.

Physical data (cont)



19XR,XRV HEAT EXCHANGER WEIGHTS — SINGLE-STAGE COMPRESSOR AND TWO-STAGE COMPRESSOR FRAME SIZE E — COMPRESSOR END ENTERING COOLER WATER

| CODE† | ENGLISH | | | | | | SI | | | | | |
|-------|--------------------------|----------------|-------------------------|-----------|-------------------|-----------|--------------------------|----------------|-------------------------|-----------|-------------------|-----------|
| | Dry Rigging Weight (lb)* | | Machine Charge | | | | Dry Rigging Weight (kg)* | | Machine Charge | | | |
| | Cooler Only | Condenser Only | Refrigerant Weight (lb) | | Water Weight (lb) | | Cooler Only | Condenser Only | Refrigerant Weight (kg) | | Water Weight (kg) | |
| | | | Cooler | Condenser | Cooler | Condenser | | | Cooler | Condenser | Cooler | Condenser |
| 10 | 2707 | 27,04 | 290 | 200 | 283 | 348 | 1228 | 1227 | 132 | 91 | 128 | 158 |
| 11 | 2777 | 27,72 | 310 | 200 | 309 | 374 | 1260 | 1257 | 141 | 91 | 140 | 170 |
| 12 | 2848 | 28,57 | 330 | 200 | 335 | 407 | 1292 | 1296 | 150 | 91 | 152 | 185 |
| 15 | 2968 | 29,84 | 320 | 250 | 327 | 402 | 1346 | 1354 | 145 | 113 | 148 | 182 |
| 16 | 3054 | 30,68 | 340 | 250 | 359 | 435 | 1385 | 1392 | 154 | 113 | 163 | 197 |
| 17 | 3141 | 31,73 | 370 | 250 | 391 | 475 | 1425 | 1439 | 168 | 113 | 177 | 215 |
| 20 | 3407 | 33,73 | 345 | 225 | 402 | 398 | 1545 | 1530 | 156 | 102 | 182 | 181 |
| 21 | 3555 | 35,40 | 385 | 225 | 456 | 462 | 1613 | 1606 | 175 | 102 | 207 | 210 |
| 22 | 3711 | 37,04 | 435 | 225 | 514 | 526 | 1683 | 1680 | 197 | 102 | 233 | 239 |
| 30 | 4071 | 36,94 | 350 | 260 | 464 | 464 | 1847 | 1676 | 159 | 118 | 210 | 210 |
| 31 | 4253 | 38,99 | 420 | 260 | 531 | 543 | 1929 | 1769 | 191 | 118 | 241 | 246 |
| 32 | 4445 | 41,00 | 490 | 260 | 601 | 621 | 2016 | 1860 | 222 | 118 | 273 | 282 |
| 35 | 4343 | 46,06 | 400 | 310 | 511 | 513 | 1970 | 2089 | 181 | 141 | 232 | 233 |
| 36 | 4551 | 48,40 | 480 | 310 | 587 | 603 | 2064 | 2195 | 218 | 141 | 266 | 274 |
| 37 | 4769 | 50,69 | 550 | 310 | 667 | 692 | 2163 | 2299 | 249 | 141 | 303 | 314 |
| 40 | 4908 | 50,39 | 560 | 338 | 863 | 915 | 2226 | 2286 | 254 | 153 | 391 | 415 |
| 41 | 5078 | 52,32 | 630 | 338 | 930 | 995 | 2303 | 2373 | 286 | 153 | 422 | 451 |
| 42 | 5226 | 54,24 | 690 | 338 | 990 | 1074 | 2370 | 2460 | 313 | 153 | 449 | 487 |
| 45 | 5363 | 56,02 | 640 | 383 | 938 | 998 | 2433 | 2541 | 290 | 174 | 425 | 453 |
| 46 | 5559 | 58,24 | 720 | 383 | 1014 | 1088 | 2522 | 2642 | 327 | 174 | 460 | 494 |
| 47 | 5730 | 60,44 | 790 | 383 | 1083 | 1179 | 2599 | 2742 | 358 | 174 | 491 | 535 |
| 50 | 5713 | 60,90 | 750 | 446 | 1101 | 1225 | 2591 | 2762 | 340 | 202 | 499 | 556 |
| 51 | 5940 | 62,83 | 840 | 446 | 1192 | 1304 | 2694 | 2850 | 381 | 202 | 541 | 591 |
| 52 | 6083 | 64,64 | 900 | 446 | 1248 | 1379 | 2759 | 2932 | 408 | 202 | 566 | 626 |
| 53 | 6141 | 65,29 | 900 | 446 | 1277 | 1409 | 2788 | 2964 | 408 | 202 | 580 | 640 |
| 54 | 6192 | 65,91 | 900 | 446 | 1302 | 1439 | 2811 | 2992 | 408 | 202 | 591 | 653 |
| 55 | 6257 | 67,85 | 870 | 509 | 1201 | 1339 | 2838 | 3078 | 395 | 231 | 545 | 607 |
| 56 | 6517 | 70,07 | 940 | 509 | 1304 | 1429 | 2956 | 3178 | 426 | 231 | 591 | 648 |
| 57 | 6682 | 72,15 | 980 | 509 | 1369 | 1514 | 3031 | 3273 | 445 | 231 | 621 | 687 |
| 58 | 6751 | 72,91 | 980 | 509 | 1401 | 1550 | 3065 | 3310 | 445 | 231 | 636 | 704 |
| 59 | 6811 | 73,63 | 980 | 509 | 1430 | 1583 | 3092 | 3343 | 445 | 231 | 649 | 719 |
| 5A | 5124 | — | 500 | — | 1023 | — | 2324 | — | 227 | — | 464 | — |
| 5B | 5177 | — | 520 | — | 1050 | — | 2348 | — | 236 | — | 476 | — |
| 5C | 5243 | — | 550 | — | 1079 | — | 2378 | — | 249 | — | 489 | — |
| 5F | 5577 | — | 550 | — | 1113 | — | 2530 | — | 249 | — | 505 | — |
| 5G | 5640 | — | 570 | — | 1143 | — | 2558 | — | 259 | — | 518 | — |
| 5H | 5716 | — | 600 | — | 1176 | — | 2593 | — | 272 | — | 533 | — |
| 5K | 4993 | — | 673 | — | 1067 | — | 2267 | — | 306 | — | 484 | — |
| 5L | 5090 | — | 706 | — | 1118 | — | 2311 | — | 321 | — | 508 | — |
| 5M | 5165 | — | 742 | — | 1162 | — | 2345 | — | 337 | — | 528 | — |
| 5P | 5041 | — | 641 | — | 1111 | — | 2289 | — | 291 | — | 504 | — |
| 5Q | 5131 | — | 678 | — | 1155 | — | 2329 | — | 308 | — | 524 | — |
| 5R | 5214 | — | 709 | — | 1206 | — | 2367 | — | 322 | — | 548 | — |
| 5T | 5425 | — | 768 | — | 1162 | — | 2463 | — | 349 | — | 528 | — |
| 5U | 5534 | — | 801 | — | 1220 | — | 2512 | — | 364 | — | 554 | — |
| 5V | 5620 | — | 843 | — | 1270 | — | 2551 | — | 383 | — | 577 | — |
| 5X | 5484 | — | 730 | — | 1212 | — | 2490 | — | 331 | — | 550 | — |
| 5Y | 5584 | — | 769 | — | 1262 | — | 2535 | — | 349 | — | 573 | — |
| 5Z | 5678 | — | 805 | — | 1320 | — | 2578 | — | 365 | — | 599 | — |
| 60 | 6719 | 67,64 | 940 | 479 | 1400 | 1521 | 3048 | 3068 | 426 | 217 | 635 | 690 |
| 61 | 6895 | 69,49 | 980 | 479 | 1470 | 1597 | 3128 | 3152 | 445 | 217 | 667 | 724 |
| 62 | 7038 | 71,30 | 1020 | 479 | 1527 | 1671 | 3192 | 3234 | 463 | 217 | 693 | 758 |
| 63 | 7103 | 71,99 | 1020 | 479 | 1559 | 1704 | 3225 | 3268 | 463 | 217 | 708 | 773 |
| 64 | 7161 | 72,64 | 1020 | 479 | 1587 | 1735 | 3251 | 3298 | 463 | 217 | 720 | 788 |
| 65 | 7392 | 76,82 | 1020 | 542 | 1530 | 1667 | 3353 | 3484 | 463 | 246 | 694 | 756 |
| 66 | 7594 | 78,94 | 1060 | 542 | 1610 | 1753 | 3445 | 3581 | 481 | 246 | 730 | 795 |
| 67 | 7759 | 81,02 | 1090 | 542 | 1674 | 1838 | 3519 | 3675 | 494 | 246 | 759 | 834 |
| 68 | 7836 | 81,82 | 1090 | 542 | 1711 | 1875 | 3558 | 3715 | 494 | 246 | 777 | 851 |
| 69 | 7905 | 82,58 | 1090 | 542 | 1743 | 1911 | 3589 | 3749 | 494 | 246 | 791 | 868 |

*Rigging weights are for standard tubes of standard wall thickness (0.025-in. [0.635 mm] wall).

†Heat exchanger frame sizes 1 through 6 available on single-stage chillers only.

NOTES:

1. Cooler includes the control panel (ICVC), suction elbow, and 1/2 the distribution piping weight.

2. Condenser includes float valve and sump, discharge elbow, and 1/2 the distribution piping weight.

3. For special tubes refer to the 19XR,XRV Computer Selection Program.

4. All weights for standard 2-pass NIH (nozzle-in-head) design.

5. For "E" compressor, add 1054 lb (478 kg) steel weight and 283 lb (128 kg) refrigerant weight for economizer assembly.

19XR,XRV HEAT EXCHANGER WEIGHTS — SINGLE-STAGE COMPRESSOR AND TWO-STAGE COMPRESSOR FRAME SIZE E — COMPRESSOR END ENTERING COOLER WATER (cont)

| CODE† | ENGLISH | | | | | | SI | | | | | |
|-------|--------------------------|----------------|-------------------------|-----------|-------------------|-----------|--------------------------|----------------|-------------------------|-----------|-------------------|-----------|
| | Dry Rigging Weight (lb)* | | Machine Charge | | | | Dry Rigging Weight (kg)* | | Machine Charge | | | |
| | Cooler Only | Condenser Only | Refrigerant Weight (lb) | | Water Weight (lb) | | Cooler Only | Condenser Only | Refrigerant Weight (kg) | | Water Weight (kg) | |
| | | | Cooler | Condenser | Cooler | Condenser | | | Cooler | Condenser | Cooler | Condenser |
| 6K | 5,716 | — | 760 | — | 1291 | — | 2595 | — | 345 | — | 586 | — |
| 6L | 5,804 | — | 797 | — | 1341 | — | 2635 | — | 362 | — | 609 | — |
| 6M | 5,894 | — | 828 | — | 1399 | — | 2676 | — | 376 | — | 635 | — |
| 6P | 5,768 | — | 725 | — | 1338 | — | 2619 | — | 329 | — | 607 | — |
| 6Q | 5,852 | — | 764 | — | 1385 | — | 2657 | — | 347 | — | 629 | — |
| 6R | 5,938 | — | 798 | — | 1439 | — | 2696 | — | 362 | — | 653 | — |
| 6T | 6,230 | — | 863 | — | 1405 | — | 2828 | — | 392 | — | 638 | — |
| 6U | 6,330 | — | 905 | — | 1462 | — | 2874 | — | 411 | — | 664 | — |
| 6V | 6,433 | — | 941 | — | 1528 | — | 2921 | — | 427 | — | 694 | — |
| 6X | 6,293 | — | 823 | — | 1459 | — | 2857 | — | 374 | — | 662 | — |
| 6Y | 6,388 | — | 868 | — | 1512 | — | 2900 | — | 394 | — | 686 | — |
| 6Z | 6,487 | — | 906 | — | 1574 | — | 2945 | — | 411 | — | 715 | — |
| 70 | 9,942 | 10,786 | 1220 | 840 | 2008 | 2225 | 4510 | 4893 | 553 | 381 | 911 | 1009 |
| 71 | 10,330 | 11,211 | 1340 | 840 | 2164 | 2389 | 4686 | 5085 | 608 | 381 | 982 | 1084 |
| 72 | 10,632 | 11,622 | 1440 | 840 | 2286 | 2548 | 4823 | 5278 | 653 | 381 | 1037 | 1156 |
| 73 | 10,715 | 11,737 | 1440 | 840 | 2328 | 2604 | 4865 | 5329 | 654 | 381 | 1057 | 1182 |
| 74 | 10,790 | 11,775 | 1440 | 840 | 2366 | 2622 | 4899 | 5346 | 654 | 381 | 1074 | 1190 |
| 75 | 10,840 | 11,859 | 1365 | 950 | 2183 | 2431 | 4917 | 5379 | 619 | 431 | 990 | 1103 |
| 76 | 11,289 | 12,345 | 1505 | 950 | 2361 | 2619 | 5121 | 5600 | 683 | 431 | 1071 | 1188 |
| 77 | 11,638 | 12,814 | 1625 | 950 | 2501 | 2801 | 5279 | 5812 | 737 | 431 | 1134 | 1271 |
| 78 | 11,738 | 12,949 | 1625 | 950 | 2548 | 2864 | 5329 | 5879 | 738 | 431 | 1157 | 1300 |
| 79 | 11,828 | 12,994 | 1625 | 950 | 2592 | 2885 | 5370 | 5899 | 738 | 431 | 1177 | 1310 |
| 7K | 8,728 | — | 1047 | — | 1948 | — | 3963 | — | 475 | — | 884 | — |
| 7L | 8,959 | — | 1132 | — | 2094 | — | 4067 | — | 514 | — | 951 | — |
| 7M | 9,161 | — | 1214 | — | 2229 | — | 4159 | — | 551 | — | 1012 | — |
| 7P | 8,792 | — | 1002 | — | 2010 | — | 3992 | — | 455 | — | 913 | — |
| 7Q | 9,023 | — | 1087 | — | 2156 | — | 4096 | — | 493 | — | 979 | — |
| 7R | 9,229 | — | 1167 | — | 2295 | — | 4190 | — | 530 | — | 1042 | — |
| 7T | 9,431 | — | 1194 | — | 2115 | — | 4282 | — | 542 | — | 960 | — |
| 7U | 9,698 | — | 1292 | — | 2282 | — | 4403 | — | 587 | — | 1036 | — |
| 7V | 9,932 | — | 1403 | — | 2436 | — | 4509 | — | 637 | — | 1106 | — |
| 7X | 9,510 | — | 1142 | — | 2185 | — | 4318 | — | 518 | — | 992 | — |
| 7Y | 9,777 | — | 1240 | — | 2352 | — | 4439 | — | 563 | — | 1068 | — |
| 7Z | 10,016 | — | 1347 | — | 2511 | — | 4547 | — | 612 | — | 1140 | — |
| 80 | 12,664 | 12,753 | 1500 | 836 | 2726 | 2977 | 5744 | 5785 | 680 | 379 | 1236 | 1350 |
| 81 | 12,998 | 13,149 | 1620 | 836 | 2863 | 3143 | 5896 | 5964 | 735 | 379 | 1299 | 1426 |
| 82 | 13,347 | 13,545 | 1730 | 836 | 3005 | 3309 | 6054 | 6144 | 785 | 379 | 1363 | 1501 |
| 83 | 13,437 | 13,872 | 1730 | 836 | 3053 | 3476 | 6100 | 6298 | 785 | 379 | 1386 | 1578 |
| 84 | 13,523 | 14,217 | 1730 | 836 | 3099 | 3651 | 6139 | 6455 | 785 | 379 | 1407 | 1658 |
| 85 | 13,804 | 14,008 | 1690 | 945 | 2951 | 3238 | 6261 | 6354 | 767 | 429 | 1339 | 1469 |
| 86 | 14,191 | 14,465 | 1820 | 945 | 3108 | 3428 | 6437 | 6561 | 826 | 429 | 1410 | 1555 |
| 87 | 14,597 | 14,923 | 1940 | 945 | 3271 | 3618 | 6621 | 6769 | 880 | 429 | 1484 | 1641 |
| 88 | 14,705 | 15,311 | 1940 | 945 | 3325 | 3808 | 6676 | 6951 | 881 | 429 | 1510 | 1729 |
| 89 | 14,808 | 15,721 | 1940 | 945 | 3378 | 4009 | 6723 | 7137 | 881 | 429 | 1534 | 1820 |
| 8K | 11,153 | — | 1385 | — | 2760 | — | 5063 | — | 629 | — | 1253 | — |
| 8L | 11,400 | — | 1484 | — | 2926 | — | 5176 | — | 674 | — | 1328 | — |
| 8M | 11,650 | — | 1589 | — | 3088 | — | 5289 | — | 721 | — | 1402 | — |
| 8P | 11,219 | — | 1334 | — | 2830 | — | 5093 | — | 606 | — | 1285 | — |
| 8Q | 11,470 | — | 1430 | — | 2999 | — | 5207 | — | 649 | — | 1362 | — |
| 8R | 11,719 | — | 1535 | — | 3161 | — | 5320 | — | 697 | — | 1435 | — |
| 8T | 12,069 | — | 1580 | — | 2991 | — | 5479 | — | 717 | — | 1358 | — |
| 8U | 12,357 | — | 1694 | — | 3180 | — | 5610 | — | 769 | — | 1444 | — |
| 8V | 12,645 | — | 1814 | — | 3365 | — | 5741 | — | 824 | — | 1528 | — |
| 8X | 12,152 | — | 1522 | — | 3070 | — | 5517 | — | 691 | — | 1394 | — |
| 8Y | 12,444 | — | 1632 | — | 3264 | — | 5650 | — | 741 | — | 1482 | — |
| 8Z | 12,733 | — | 1752 | — | 3448 | — | 5781 | — | 795 | — | 1565 | — |

*Rigging weights are for standard tubes of standard wall thickness (0.025-in. [0.635 mm] wall).

†Heat exchanger frame sizes 1 through 6 available on single-stage chillers only.

NOTES:

1. Cooler includes the control panel (ICVC), suction elbow, and 1/2 the distribution piping weight.
2. Condenser includes float valve and sump, discharge elbow, and 1/2 the distribution piping weight.
3. For special tubes refer to the 19XR,XRV Computer Selection Program.
4. All weights for standard 2-pass NIH (nozzle-in-head) design.

5. For "E" compressor, add 1054 lb (478 kg) steel weight and 283 lb (128 kg) refrigerant weight for economizer assembly.

Physical data (cont)



19XR TWO-STAGE COMPRESSOR FRAME SIZE 6 HEAT EXCHANGER WEIGHTS (ENGLISH)

| CODE† | DRY RIGGING WEIGHT (lb)* | | REFRIGERANT WEIGHT (lb) | | WATER WEIGHT (lb) | |
|-------|--------------------------|----------------|-------------------------|----------------|-------------------|----------------|
| | COOLER ONLY | CONDENSER ONLY | COOLER ONLY | CONDENSER ONLY | COOLER ONLY | CONDENSER ONLY |
| A40 | 16,877 | 18542 | 1647 | 927 | 4328 | 4553 |
| A41 | 17,270 | 19062 | 1773 | 927 | 4557 | 4890 |
| A42 | 17,690 | 19565 | 1887 | 927 | 4816 | 5213 |
| A45 | 16,968 | 18493 | 1599 | 927 | 4453 | 4582 |
| A46 | 17,371 | 19063 | 1714 | 927 | 4701 | 4949 |
| A47 | 17,761 | 19578 | 1837 | 927 | 4941 | 5281 |
| A60 | 18,354 | 20,139 | 1878 | 1074 | 4721 | 5029 |
| A61 | 18,807 | 20,745 | 2022 | 1074 | 4984 | 5415 |
| A62 | 19,295 | 21,330 | 2152 | 1074 | 5280 | 5786 |
| A65 | 18,469 | 20,095 | 1823 | 1074 | 4859 | 5060 |
| A66 | 18,936 | 20,758 | 1954 | 1074 | 5144 | 5482 |
| A67 | 19,389 | 21,357 | 2095 | 1074 | 5419 | 5862 |
| A4A | 15,540 | 17,089 | 1681 | 861 | 4183 | 4524 |
| A4B | 15,794 | 17,472 | 1792 | 861 | 4392 | 4859 |
| A4C | 16,063 | 17,812 | 1897 | 861 | 4615 | 5137 |
| A4F | 15,592 | 17,076 | 1626 | 861 | 4322 | 4588 |
| A4G | 15,845 | 17,405 | 1736 | 861 | 4531 | 4867 |
| A4H | 16,249 | 17,821 | 1890 | 861 | 4865 | 5219 |
| A6A | 16,465 | 18,359 | 1917 | 998 | 4555 | 4996 |
| A6B | 16,758 | 18,806 | 2044 | 998 | 4794 | 5368 |
| A6C | 17,070 | 19,202 | 2164 | 998 | 5050 | 5698 |
| A6F | 16,535 | 18,356 | 1854 | 998 | 4709 | 5068 |
| A6G | 16,829 | 18,739 | 1979 | 998 | 4948 | 5387 |
| A6H | 17,296 | 19,225 | 2156 | 998 | 5331 | 6156 |
| B40 | — | 21,217 | — | 1233 | — | 5850 |
| B41 | — | 21,965 | — | 1233 | — | 6333 |
| B42 | — | 22,581 | — | 1233 | — | 6729 |
| B45 | — | 21,173 | — | 1233 | — | 5904 |
| B46 | — | 21,909 | — | 1233 | — | 6379 |
| B47 | — | 22,653 | — | 1233 | — | 6859 |
| B60 | — | 23,061 | — | 1423 | — | 6464 |
| B61 | — | 23,932 | — | 1423 | — | 7018 |
| B62 | — | 24,649 | — | 1423 | — | 7473 |
| B65 | — | 23,022 | — | 1423 | — | 6521 |
| B66 | — | 23,879 | — | 1423 | — | 7066 |
| B67 | — | 24,745 | — | 1423 | — | 7617 |
| B4A | — | 19,217 | — | 1148 | — | 5756 |
| B4B | — | 19,793 | — | 1148 | — | 6243 |
| B4C | — | 20,254 | — | 1148 | — | 6633 |
| B4F | — | 19,217 | — | 1148 | — | 5852 |
| B4G | — | 19,721 | — | 1148 | — | 6279 |
| B4H | — | 20,318 | — | 1148 | — | 6785 |
| B6A | — | 20,794 | — | 1326 | — | 6357 |
| B6B | — | 21,465 | — | 1326 | — | 6915 |
| B6C | — | 22,002 | — | 1326 | — | 7362 |
| B6F | — | 20,806 | — | 1326 | — | 6462 |
| B6G | — | 21,393 | — | 1326 | — | 6951 |
| B6H | — | 22,088 | — | 1326 | — | 8379 |

*Rigging weights are for standard tubes of standard wall thickness (0.025-in. [0.635 mm] wall).
†See Model Number Nomenclature for 19XR Two-Stage Compressor Frame Size 6 and 7 on page 8.

NOTES:

1. Cooler weight includes the suction elbow and the distribution piping to the economizer and two-pass Victaulic dished heads.
2. Condenser weight includes the high side float chamber, discharge pipe, and the distribution piping weight from the economizer to the float chamber and two-pass Victaulic dished heads.

19XR TWO-STAGE COMPRESSOR FRAME SIZE 6 HEAT EXCHANGER WEIGHTS (SI)

| CODE† | DRY RIGGING WEIGHT (kg)* | | REFRIGERANT WEIGHT (kg) | | WATER WEIGHT (kg) | |
|-------|--------------------------|----------------|-------------------------|----------------|-------------------|----------------|
| | COOLER ONLY | CONDENSER ONLY | COOLER ONLY | CONDENSER ONLY | COOLER ONLY | CONDENSER ONLY |
| A40 | 7655 | 8 410 | 747 | 420 | 1963 | 2065 |
| A41 | 7833 | 8 646 | 804 | 420 | 2067 | 2218 |
| A42 | 8024 | 8 875 | 856 | 420 | 2184 | 2365 |
| A45 | 7697 | 8 388 | 725 | 420 | 2020 | 2078 |
| A46 | 7879 | 8 647 | 777 | 420 | 2132 | 2245 |
| A47 | 8056 | 8 880 | 833 | 420 | 2241 | 2395 |
| A60 | 8325 | 9 135 | 852 | 487 | 2141 | 2281 |
| A61 | 8531 | 9 410 | 917 | 487 | 2261 | 2456 |
| A62 | 8752 | 9 675 | 976 | 487 | 2395 | 2624 |
| A65 | 8377 | 9 115 | 827 | 487 | 2204 | 2295 |
| A66 | 8589 | 9 416 | 886 | 487 | 2333 | 2487 |
| A67 | 8795 | 9 687 | 950 | 487 | 2458 | 2659 |
| A4A | 7049 | 7 751 | 762 | 391 | 1897 | 2052 |
| A4B | 7164 | 7 925 | 813 | 391 | 1992 | 2204 |
| A4C | 7286 | 8 079 | 860 | 391 | 2093 | 2330 |
| A4F | 7072 | 7 746 | 738 | 391 | 1960 | 2081 |
| A4G | 7187 | 7 895 | 787 | 391 | 2055 | 2208 |
| A4H | 7370 | 8 083 | 857 | 391 | 2207 | 2367 |
| A6A | 7468 | 8 328 | 870 | 453 | 2066 | 2266 |
| A6B | 7601 | 8 530 | 927 | 453 | 2175 | 2435 |
| A6C | 7743 | 8 710 | 982 | 453 | 2291 | 2585 |
| A6F | 7500 | 8 326 | 841 | 453 | 2136 | 2299 |
| A6G | 7633 | 8 500 | 898 | 453 | 2244 | 2444 |
| A6H | 7845 | 8 730 | 978 | 453 | 2418 | 2792 |
| B40 | — | 9 624 | — | 559 | — | 2653 |
| B41 | — | 9 963 | — | 559 | — | 2873 |
| B42 | — | 10 243 | — | 559 | — | 3052 |
| B45 | — | 9 604 | — | 559 | — | 2678 |
| B46 | — | 9 938 | — | 559 | — | 2893 |
| B47 | — | 10 275 | — | 559 | — | 3111 |
| B60 | — | 10 460 | — | 645 | — | 2932 |
| B61 | — | 10 855 | — | 645 | — | 3183 |
| B62 | — | 11 181 | — | 645 | — | 3390 |
| B65 | — | 10 442 | — | 645 | — | 2958 |
| B66 | — | 10 831 | — | 645 | — | 3205 |
| B67 | — | 11 224 | — | 645 | — | 3455 |
| B4A | — | 8 717 | — | 521 | — | 2611 |
| B4B | — | 8 978 | — | 521 | — | 2832 |
| B4C | — | 9 187 | — | 521 | — | 3009 |
| B4F | — | 8 717 | — | 521 | — | 2654 |
| B4G | — | 8 945 | — | 521 | — | 2848 |
| B4H | — | 9 216 | — | 521 | — | 3078 |
| B6A | — | 9 432 | — | 601 | — | 2883 |
| B6B | — | 9 736 | — | 601 | — | 3137 |
| B6C | — | 9 980 | — | 601 | — | 3339 |
| B6F | — | 9 487 | — | 601 | — | 2931 |
| B6G | — | 9 704 | — | 601 | — | 3153 |
| B6H | — | 10 019 | — | 601 | — | 3801 |

*Rigging weights are for standard tubes of standard wall thickness (0.025-in. [0.635 mm] wall).
†See Model Number Nomenclature for 19XR Two-Stage Compressor Frame Size 6 and 7 on page 8.

NOTES:

1. Cooler weight includes the suction elbow and the distribution piping to the economizer and two-pass Victaulic dished heads.
2. Condenser weight includes the high side float chamber, discharge pipe, and the distribution piping weight from the economizer to the float chamber and two-pass Victaulic dished heads.

Physical data (cont)



19XR TWO-STAGE COMPRESSOR FRAME SIZE 7 HEAT EXCHANGER WEIGHTS (ENGLISH)

| CODE† | DRY RIGGING WEIGHT (lb)* | | REFRIGERANT WEIGHT (lb) | | WATER WEIGHT (lb) | |
|-------|--------------------------|----------------|-------------------------|----------------|-------------------|----------------|
| | COOLER ONLY | CONDENSER ONLY | COOLER ONLY | CONDENSER ONLY | COOLER ONLY | CONDENSER ONLY |
| B60 | 24,704 | — | 2273 | — | 6340 | — |
| B61 | 25,337 | — | 2355 | — | 6737 | — |
| B62 | 25,964 | — | 2460 | — | 7116 | — |
| B65 | 25,014 | — | 2185 | — | 6485 | — |
| B66 | 25,631 | — | 2275 | — | 6873 | — |
| B67 | 26,264 | — | 2379 | — | 7255 | — |
| B6A | 22,819 | — | 2081 | — | 6159 | — |
| B6B | 23,299 | — | 2162 | — | 6568 | — |
| B6C | 23,829 | — | 2256 | — | 6993 | — |
| B6F | 23,139 | — | 1951 | — | 6344 | — |
| B6G | 23,648 | — | 2019 | — | 6774 | — |
| B6H | 24,171 | — | 2120 | — | 7194 | — |
| B80 | 26,184 | — | 2557 | — | 6766 | — |
| B81 | 26,922 | — | 2649 | — | 7208 | — |
| B82 | 27,627 | — | 2768 | — | 7629 | — |
| B85 | 26,438 | — | 2458 | — | 6923 | — |
| B86 | 27,157 | — | 2559 | — | 7355 | — |
| B87 | 27,868 | — | 2676 | — | 7780 | — |
| B8A | 24,164 | — | 2341 | — | 6580 | — |
| B8B | 24,722 | — | 2432 | — | 7036 | — |
| B8C | 25,317 | — | 2538 | — | 7510 | — |
| B8F | 24,403 | — | 2195 | — | 6783 | — |
| B8G | 25,011 | — | 2271 | — | 7262 | — |
| B8H | 25,599 | — | 2385 | — | 7731 | — |
| C60 | 30,825 | 29,857 | 2647 | 1610 | 8475 | 8,630 |
| C61 | 31,536 | 30,881 | 2751 | 1610 | 8924 | 9,275 |
| C62 | 32,467 | 31,871 | 2875 | 1610 | 9474 | 9,916 |
| C65 | 31,135 | 29,982 | 2562 | 1610 | 8645 | 8,684 |
| C66 | 31,851 | 31,064 | 2666 | 1610 | 9097 | 9,362 |
| C67 | 32,777 | 32,186 | 2793 | 1610 | 9644 | 10,078 |
| C6A | 28,641 | 27,676 | 2443 | 1497 | 6898 | 8,675 |
| C6B | 29,167 | 28,315 | 2534 | 1497 | 7352 | 9,216 |
| C6C | 29,750 | 28,918 | 2627 | 1497 | 7823 | 9,752 |
| C6F | 28,929 | 27,774 | 2334 | 1497 | 7724 | 8,710 |
| C6G | 29,478 | 28,457 | 2415 | 1497 | 8194 | 9,283 |
| C6H | 30,083 | 29,223 | 2500 | 1497 | 8681 | 9,935 |
| C80 | — | 31,810 | — | 1811 | — | 9,312 |
| C81 | — | 32,955 | — | 1811 | — | 10,029 |
| C82 | — | 34,094 | — | 1811 | — | 10,742 |
| C85 | — | 31,911 | — | 1811 | — | 9,367 |
| C86 | — | 33,113 | — | 1811 | — | 10,120 |
| C87 | — | 34,385 | — | 1811 | — | 10,196 |
| C8A | — | 19,664 | — | 1684 | — | 9,387 |
| C8B | — | 19,548 | — | 1684 | — | 9,991 |
| C8C | — | 19,463 | — | 1684 | — | 10,589 |
| C8F | — | 19,763 | — | 1684 | — | 9,420 |
| C8G | — | 19,641 | — | 1684 | — | 10,059 |
| C8H | — | 19,503 | — | 1684 | — | 10,787 |
| D60 | — | 38,296 | — | 2097 | — | 11,473 |
| D61 | — | 39,624 | — | 2097 | — | 12,309 |
| D62 | — | 41,031 | — | 2097 | — | 13,210 |
| D65 | — | 37,624 | — | 2097 | — | 11,617 |
| D66 | — | 38,837 | — | 2097 | — | 12,387 |
| D67 | — | 40,460 | — | 2097 | — | 13,410 |
| D6A | — | 35,286 | — | 1947 | — | 11,401 |
| D6B | — | 36,328 | — | 1947 | — | 12,255 |
| D6C | — | 37,288 | — | 1947 | — | 13,078 |
| D6F | — | 34,447 | — | 1947 | — | 11,448 |
| D6G | — | 35,637 | — | 1947 | — | 12,408 |
| D6H | — | 36,663 | — | 1947 | — | 13,278 |

*Rigging weights are for standard tubes of standard wall thickness (0.025-in. [0.635 mm] wall).
†See Model Number Nomenclature for 19XR Two-Stage Compressor Frame Size 6 and 7 on page 8.

NOTES:

1. Cooler weight includes the suction elbow and the distribution piping to the economizer and two-pass Victaulic dished heads.
2. Condenser weight includes the high side float chamber, discharge pipe, and the distribution piping weight from the economizer to the float chamber and two-pass Victaulic dished heads.

19XR TWO-STAGE COMPRESSOR FRAME SIZE 7 HEAT EXCHANGER WEIGHTS (SI)

| CODE† | DRY RIGGING WEIGHT (kg)* | | REFRIGERANT WEIGHT (kg) | | WATER WEIGHT (kg) | |
|-------|--------------------------|----------------|-------------------------|----------------|-------------------|----------------|
| | COOLER ONLY | CONDENSER ONLY | COOLER ONLY | CONDENSER ONLY | COOLER ONLY | CONDENSER ONLY |
| B60 | 11206 | — | 1031 | — | 2876 | — |
| B61 | 11493 | — | 1068 | — | 3056 | — |
| B62 | 11777 | — | 1116 | — | 3228 | — |
| B65 | 11346 | — | 991 | — | 2941 | — |
| B66 | 11626 | — | 1032 | — | 3118 | — |
| B67 | 11913 | — | 1079 | — | 3291 | — |
| B6A | 10351 | — | 944 | — | 2794 | — |
| B6B | 10568 | — | 981 | — | 2979 | — |
| B6C | 10809 | — | 1023 | — | 3172 | — |
| B6F | 10496 | — | 885 | — | 2878 | — |
| B6G | 10727 | — | 916 | — | 3073 | — |
| B6H | 10964 | — | 962 | — | 3263 | — |
| B80 | 11877 | — | 1160 | — | 3069 | — |
| B81 | 12212 | — | 1202 | — | 3269 | — |
| B82 | 12531 | — | 1256 | — | 3460 | — |
| B85 | 11992 | — | 1115 | — | 3141 | — |
| B86 | 12318 | — | 1161 | — | 3336 | — |
| B87 | 11214 | — | 1214 | — | 3529 | — |
| B8A | 10952 | — | 1062 | — | 2885 | — |
| B8B | 11214 | — | 1103 | — | 3191 | — |
| B8C | 11484 | — | 1151 | — | 3406 | — |
| B8F | 11069 | — | 996 | — | 3077 | — |
| B8G | 11345 | — | 1030 | — | 3294 | — |
| B8H | 11612 | — | 1082 | — | 3507 | — |
| C60 | 13982 | 13543 | 1201 | 730 | 3841 | 3914 |
| C61 | 14304 | 14007 | 1248 | 730 | 4048 | 4207 |
| C62 | 14727 | 14456 | 1304 | 730 | 4297 | 4498 |
| C65 | 14123 | 13600 | 1162 | 730 | 3921 | 3939 |
| C66 | 14447 | 14090 | 1209 | 730 | 4126 | 4247 |
| C67 | 14867 | 14599 | 1267 | 730 | 4374 | 4571 |
| C6A | 12991 | 12554 | 1108 | 679 | 3129 | 3935 |
| C6B | 13230 | 12843 | 1149 | 679 | 3325 | 4180 |
| C6C | 13494 | 13117 | 1192 | 679 | 3553 | 4423 |
| C6F | 13,22 | 12508 | 1059 | 679 | 3504 | 3951 |
| C6G | 13371 | 12908 | 1095 | 679 | 3717 | 4211 |
| C6H | 13645 | 13255 | 1134 | 679 | 3938 | 4506 |
| C80 | — | 14429 | — | 821 | — | 4224 |
| C81 | — | 14948 | — | 821 | — | 4549 |
| C82 | — | 15465 | — | 821 | — | 4872 |
| C85 | — | 14475 | — | 821 | — | 4249 |
| C86 | — | 14020 | — | 821 | — | 4590 |
| C87 | — | 15597 | — | 821 | — | 4625 |
| C8A | — | 8919 | — | 764 | — | 4258 |
| C8B | — | 8867 | — | 764 | — | 4532 |
| C8C | — | 8816 | — | 764 | — | 4803 |
| C8F | — | 8964 | — | 764 | — | 4273 |
| C8G | — | 8909 | — | 764 | — | 4563 |
| C8H | — | 8846 | — | 764 | — | 4893 |
| D60 | — | 17371 | — | 951 | — | 5204 |
| D61 | — | 17973 | — | 951 | — | 5583 |
| D62 | — | 18611 | — | 951 | — | 5992 |
| D65 | — | 17066 | — | 951 | — | 5269 |
| D66 | — | 17616 | — | 951 | — | 5619 |
| D67 | — | 18352 | — | 951 | — | 6083 |
| D6A | — | 16005 | — | 883 | — | 5171 |
| D6B | — | 16478 | — | 883 | — | 5559 |
| D6C | — | 16914 | — | 883 | — | 5932 |
| D6F | — | 15625 | — | 883 | — | 5193 |
| D6G | — | 16165 | — | 883 | — | 5628 |
| D6H | — | 16630 | — | 883 | — | 6023 |

*Rigging weights are for standard tubes of standard wall thickness (0.025-in. [0.635 mm] wall).
†See Model Number Nomenclature for 19XR Two-Stage Compressor Frame Size 6 and 7 on page 8.

NOTES:

1. Cooler weight includes the suction elbow and the distribution piping to the economizer and two-pass Victaulic dished heads.
2. Condenser weight includes the high side float chamber, discharge pipe, and the distribution piping weight from the economizer to the float chamber and two-pass Victaulic dished heads.

Physical data (cont)



19XR TWO-STAGE COMPRESSOR FRAME SIZES 6 AND 7 ECONOMIZER WEIGHT

| FRAME SIZE | DRY WEIGHT (lb)* | REFRIGERANT WEIGHT (lb) | OPERATION WEIGHT (lb) | DRY WEIGHT (kg)* | REFRIGERANT WEIGHT (kg) | OPERATION WEIGHT (kg) |
|------------|------------------|-------------------------|-----------------------|------------------|-------------------------|-----------------------|
| XR6 | 1589 | 360 | 1949 | 721 | 163 | 884 |
| XR7 | 2749 | 646 | 3395 | 1247 | 293 | 1540 |

*Includes economizer weight and all the connecting piping to the compressor.

ADDITIONAL WEIGHTS FOR 19XR,XRV MARINE WATERBOXES*

150 psig (1034 kPa) MARINE WATERBOXES — SINGLE-STAGE COMPRESSORS

| FRAME† | NUMBER OF PASSES | ENGLISH (lb) | | | | SI (kg) | | | |
|---------|------------------|--------------|-----------|-------------|-----------|-------------|-----------|-------------|-----------|
| | | Cooler | | Condenser | | Cooler | | Condenser | |
| | | Rigging Wgt | Water Wgt | Rigging Wgt | Water Wgt | Rigging Wgt | Water Wgt | Rigging Wgt | Water Wgt |
| 1 | 1&3 | N/A | N/A | N/A | N/A | N/A | N/A | N/A | N/A |
| | 2 | N/A | N/A | N/A | N/A | N/A | N/A | N/A | N/A |
| 2 and 3 | 1&3 | 730 | 700 | N/A | N/A | 331 | 318 | N/A | N/A |
| | 2 | 365 | 350 | 365 | 350 | 166 | 159 | 166 | 159 |
| 4 | 1&3 | 1888 | 908 | N/A | N/A | 856 | 412 | N/A | N/A |
| | 2 | 944 | 452 | 989 | 452 | 428 | 205 | 449 | 205 |
| 5 | 1&3 | 2445 | 1019 | N/A | N/A | 1109 | 462 | N/A | N/A |
| | 2 | 1223 | 510 | 1195 | 499 | 555 | 231 | 542 | 226 |
| 6 | 1&3 | 2860 | 1155 | N/A | N/A | 1297 | 524 | N/A | N/A |
| | 2 | 1430 | 578 | 1443 | 578 | 649 | 262 | 655 | 262 |
| 7 | 1&3 | 3970 | 2579 | N/A | N/A | 1801 | 1170 | N/A | N/A |
| | 2 | 1720 | 1290 | 1561 | 1025 | 780 | 585 | 708 | 465 |
| 8 | 1&3 | 5048 | 3033 | N/A | N/A | 2290 | 1376 | N/A | N/A |
| | 2 | 2182 | 1517 | 1751 | 1172 | 990 | 688 | 794 | 532 |

300 psig (2068 kPa) MARINE WATERBOXES — SINGLE-STAGE COMPRESSORS

| FRAME† | NUMBER OF PASSES | ENGLISH (lb) | | | | SI (kg) | | | |
|---------|------------------|--------------|-----------|-------------|-----------|-------------|-----------|-------------|-----------|
| | | Cooler | | Condenser | | Cooler | | Condenser | |
| | | Rigging Wgt | Water Wgt | Rigging Wgt | Water Wgt | Rigging Wgt | Water Wgt | Rigging Wgt | Water Wgt |
| 1 | 1&3 | N/A | N/A | N/A | N/A | N/A | N/A | N/A | N/A |
| | 2 | N/A | N/A | N/A | N/A | N/A | N/A | N/A | N/A |
| 2 and 3 | 1&3 | 860 | 700 | N/A | N/A | 390 | 318 | N/A | N/A |
| | 2 | 430 | 350 | 430 | 350 | 195 | 159 | 195 | 159 |
| 4 | 1&3 | 2162 | 908 | N/A | N/A | 981 | 412 | N/A | N/A |
| | 2 | 1552 | 393 | 1641 | 393 | 704 | 178 | 744 | 178 |
| 5 | 1&3 | 2655 | 1019 | N/A | N/A | 1204 | 462 | N/A | N/A |
| | 2 | 1965 | 439 | 1909 | 418 | 891 | 199 | 866 | 190 |
| 6 | 1&3 | 3330 | 1155 | N/A | N/A | 1510 | 524 | N/A | N/A |
| | 2 | 2425 | 480 | 2451 | 480 | 1100 | 218 | 1112 | 218 |
| 7 | 1&3 | 5294 | 2579 | N/A | N/A | 2401 | 1170 | N/A | N/A |
| | 2 | 4140 | 1219 | 4652 | 784 | 1878 | 553 | 2110 | 356 |
| 8 | 1&3 | 6222 | 3033 | N/A | N/A | 2822 | 1376 | N/A | N/A |
| | 2 | 4952 | 1343 | 4559 | 783 | 2246 | 609 | 2068 | 355 |

150 psig (1034 kPa) MARINE WATERBOXES — TWO-STAGE COMPRESSORS, FRAME SIZE 6 ENGLISH (lb)

| FRAME | NUMBER OF PASSES | COOLER | | | CONDENSER | | |
|-------|------------------|-------------|--------|-----------|-------------|--------|-----------|
| | | Rigging Wgt | | Water Wgt | Rigging Wgt | | Water Wgt |
| | | Victaulic | Flange | | Victaulic | Flange | |
| A | 1 | 2794 | 3124 | 6515 | 2582 | 2912 | 5648 |
| | 2 | 2454 | 2650 | 2979 | 2236 | 2432 | 2613 |
| | 3 | 2771 | 2899 | 4190 | 2840 | 3020 | 3950 |
| B | 1 | — | — | — | 2604 | 2934 | 6975 |
| | 2 | — | — | — | 2459 | 2719 | 3600 |
| | 3 | — | — | — | 2770 | 2950 | 4858 |

*Add to cooler and condenser weights for total weights. Condenser weights may be found in the Heat Exchanger Weights tables on pages 32-35. The first digit of the heat exchanger code (first column) is the heat exchanger frame size.

†Values are for Victaulic nozzles, two-pass dished head design.

ADDITIONAL WEIGHTS FOR 19XR,XRV MARINE WATERBOXES* (cont)

150 psig (1034 kPa) MARINE WATERBOXES — TWO-STAGE COMPRESSORS, FRAME SIZE 6 — SI (kg)

| FRAME | NUMBER OF PASSES | COOLER | | | CONDENSER | | |
|-------|------------------|-------------|--------|-----------|-------------|--------|-----------|
| | | Rigging Wgt | | Water Wgt | Rigging Wgt | | Water Wgt |
| | | Victaulic | Flange | | Victaulic | Flange | |
| A | 1 | 1267 | 1417 | 2955 | 1171 | 1321 | 2562 |
| | 2 | 1113 | 1202 | 2979 | 1014 | 1103 | 1185 |
| | 3 | 1157 | 1315 | 1900 | 1288 | 1370 | 1792 |
| B | 1 | — | — | — | 1181 | 1331 | 3162 |
| | 2 | — | — | — | 1115 | 1233 | 1633 |
| | 3 | — | — | — | 1256 | 1338 | 2203 |

*Add to cooler and condenser weights for total weights. Condenser weights may be found in the Heat Exchanger Weights tables on pages 32-35. The first digit of the heat exchanger code (first column) is the heat exchanger frame size.

†Values are for Victaulic nozzles, two-pass dished head design.

150 psig (1034 kPa) MARINE WATERBOXES — TWO-STAGE COMPRESSORS, FRAME SIZE 7 — ENGLISH (lb)

| FRAME | NUMBER OF PASSES | COOLER | | | CONDENSER | | |
|-------|------------------|-------------|--------|-----------|-------------|--------|-----------|
| | | Rigging Wgt | | Water Wgt | Rigging Wgt | | Water Wgt |
| | | Victaulic | Flange | | Victaulic | Flange | |
| B | 1 | 4045 | 4375 | 8103 | — | — | — |
| | 2 | 3648 | 3908 | 4139 | — | — | — |
| | 3 | 4160 | 4340 | 5633 | — | — | — |
| C | 1 | 4828 | 5158 | 10,264 | 4273 | 4713 | 9858 |
| | 2 | 4375 | 4635 | 5201 | 3714 | 4044 | 4826 |
| | 3 | 4957 | 5137 | 7144 | 4434 | 4630 | 6819 |
| D | 1 | — | — | — | 4863 | 5303 | 12530 |
| | 2 | — | — | — | 4243 | 4573 | 6074 |
| | 3 | — | — | — | 5079 | 5275 | 8659 |

*Add to cooler and condenser weights for total weights. Condenser weights may be found in the Heat Exchanger Weights tables on pages 32-35. The first digit of the heat exchanger code (first column) is the heat exchanger frame size.

†Values are for Victaulic nozzles, two-pass dished head design.

150 psig (1034 kPa) MARINE WATERBOXES — TWO-STAGE COMPRESSORS, FRAME SIZE 7 — SI (kg)

| FRAME | NUMBER OF PASSES | COOLER | | | CONDENSER | | |
|-------|------------------|-------------|--------|-----------|-------------|--------|-----------|
| | | Rigging Wgt | | Water Wgt | Rigging Wgt | | Water Wgt |
| | | Victaulic | Flange | | Victaulic | Flange | |
| B | 1 | 1835 | 1984 | 3675 | — | — | — |
| | 2 | 1655 | 1773 | 1877 | — | — | — |
| | 3 | 1887 | 1969 | 2555 | — | — | — |
| C | 1 | 2190 | 2340 | 4655 | 1938 | 2138 | 4472 |
| | 2 | 1984 | 2102 | 2359 | 1685 | 1834 | 2189 |
| | 3 | 2248 | 2330 | 3240 | 2011 | 2100 | 3093 |
| D | 1 | — | — | — | 2206 | 2405 | 5684 |
| | 2 | — | — | — | 1925 | 2074 | 2755 |
| | 3 | — | — | — | 2303 | 2393 | 3928 |

*Add to cooler and condenser weights for total weights. Condenser weights may be found in the Heat Exchanger Weights tables on pages 32-35. The first digit of the heat exchanger code (first column) is the heat exchanger frame size.

†Values are for Victaulic nozzles, two-pass dished head design.

Physical data (cont)



ADDITIONAL WEIGHTS FOR 19XR,XRV MARINE WATERBOXES* (cont)

300 psig (2068 kPa) ASME MARINE WATERBOXES — TWO-STAGE COMPRESSORS, FRAME SIZE 6* — ENGLISH (lb)

| FRAME | NUMBER OF PASSES | COOLER | | | CONDENSER | | |
|-------|------------------|-------------|--------|-----------|-------------|--------|-----------|
| | | Rigging Wgt | | Water Wgt | Rigging Wgt | | Water Wgt |
| | | Victaulic | Flange | | Victaulic | Flange | |
| A | 1 | 6379 | 6709 | 5058 | 5573 | 5903 | 4426 |
| | 2 | 5594 | 5790 | 2101 | 4834 | 5030 | 1890 |
| | 3 | 6031 | 6159 | 3005 | 5310 | 5490 | 2688 |
| B | 1 | — | — | — | 7084 | 7414 | 5509 |
| | 2 | — | — | — | 6474 | 6734 | 2577 |
| | 3 | — | — | — | 6816 | 6996 | 3340 |

300 psig (2068 kPa) ASME MARINE WATERBOXES — TWO-STAGE COMPRESSORS, FRAME SIZE 6* — SI (kg)

| FRAME | NUMBER OF PASSES | COOLER | | | CONDENSER | | |
|-------|------------------|-------------|--------|-----------|-------------|--------|-----------|
| | | Rigging Wgt | | Water Wgt | Rigging Wgt | | Water Wgt |
| | | Victaulic | Flange | | Victaulic | Flange | |
| A | 1 | 2893 | 3043 | 2294 | 2528 | 2678 | 2008 |
| | 2 | 2537 | 2626 | 953 | 2193 | 2282 | 857 |
| | 3 | 2736 | 2794 | 1363 | 2409 | 2490 | 1219 |
| B | 1 | — | — | — | 3213 | 3363 | 2499 |
| | 2 | — | — | — | 2937 | 3054 | 1169 |
| | 3 | — | — | — | 3092 | 3173 | 1515 |

*Add to cooler and condenser weights for total weights. Condenser weights may be found in the 19XR,XRV Heat Exchanger Weights tables on pages 32-35. The first digit of the heat exchanger code (first column) is the heat exchanger frame size.

300 psig (2068 kPa) ASME MARINE WATERBOXES — TWO-STAGE COMPRESSORS, FRAME SIZE 7* — ENGLISH (lb)

| FRAME | NUMBER OF PASSES | COOLER | | | CONDENSER | | |
|-------|------------------|-------------|--------|-----------|-------------|--------|-----------|
| | | Rigging Wgt | | Water Wgt | Rigging Wgt | | Water Wgt |
| | | Victaulic | Flange | | Victaulic | Flange | |
| B | 1 | 8305 | 8635 | 5783 | — | — | — |
| | 2 | 7426 | 7686 | 2382 | — | — | — |
| | 3 | 7785 | 7965 | 3268 | — | — | — |
| C | 1 | 11001 | 11331 | 7030 | 9228 | 9668 | 7591 |
| | 2 | 9829 | 10089 | 2708 | 8003 | 8333 | 3061 |
| | 3 | 10343 | 10053 | 3866 | 8647 | 8843 | 4468 |
| D | 1 | — | — | — | 12940 | 13380 | 9365 |
| | 2 | — | — | — | 11170 | 11500 | 3607 |
| | 3 | — | — | — | 12042 | 12238 | 5398 |

300 psig (2068 kPa) ASME MARINE WATERBOXES — TWO-STAGE COMPRESSORS, FRAME SIZE 7* — SI (kg)

| FRAME | NUMBER OF PASSES | COOLER | | | CONDENSER | | |
|-------|------------------|-------------|--------|-----------|-------------|--------|-----------|
| | | Rigging Wgt | | Water Wgt | Rigging Wgt | | Water Wgt |
| | | Victaulic | Flange | | Victaulic | Flange | |
| B | 1 | 3767 | 3917 | 2623 | — | — | — |
| | 2 | 3368 | 3486 | 1080 | — | — | — |
| | 3 | 3531 | 3612 | 1482 | — | — | — |
| C | 1 | 4990 | 5140 | 3188 | 4186 | 4385 | 3443 |
| | 2 | 4458 | 4576 | 1228 | 3630 | 3682 | 1388 |
| | 3 | 4692 | 4773 | 1753 | 3922 | — | — |
| D | 1 | — | — | — | 5869 | 5927 | 4547 |
| | 2 | — | — | — | 5067 | 5102 | 1925 |
| | 3 | — | — | — | 5462 | — | — |

*Add to cooler and condenser weights for total weights. Condenser weights may be found in the 19XR,XRV Heat Exchanger Weights tables on pages 32-35. The first digit of the heat exchanger code (first column) is the heat exchanger frame size.

**19XR,XRV WATERBOX COVER WEIGHTS — ENGLISH (lb)
FRAMES 1, 2, AND 3; COOLER**

| WATERBOX DESCRIPTION | COOLER | | | | | |
|--------------------------------|------------------|---------|------------------|---------|------------------|---------|
| | Frame 1 | | Frame 2 | | Frame 3 | |
| | Standard Nozzles | Flanged | Standard Nozzles | Flanged | Standard Nozzles | Flanged |
| NIH, 1 Pass Cover, 150 psig | 177 | 204 | 287 | 318 | 287 | 318 |
| NIH, 2 Pass Cover, 150 psig | 185 | 218 | 287 | 340 | 287 | 340 |
| NIH, 3 Pass Cover, 150 psig | 180 | 196 | 294 | 310 | 294 | 310 |
| MWB End Cover, 150 psig | — | — | 315 | 315 | 315 | 315 |
| NIH/MWB Return Cover, 150 psig | 136 | 136 | 243 | 243 | 243 | 243 |
| NIH, 1 Pass Cover, 300 psig | 248 | 301 | 411 | 486 | 411 | 486 |
| NIH, 2 Pass Cover, 300 psig | 255 | 324 | 411 | 518 | 411 | 518 |
| NIH, 3 Pass Cover, 300 psig | 253 | 288 | 433 | 468 | 433 | 468 |
| NIH Plain End Cover, 300 psig | 175 | 175 | 291 | 291 | 291 | 291 |
| MWB End Cover, 300 psig | — | — | 619 | 619 | 619 | 619 |
| MWB Return Cover, 300 psig | — | — | 445 | 445 | 445 | 445 |

LEGEND

NIH — Nozzle-in-Head
MWB — Marine Waterbox

NOTE: Weight for 2-pass cover, 150 psig, is included in the heat exchanger weights shown on pages 28-31.

FRAMES 1, 2, AND 3; CONDENSER

| WATERBOX DESCRIPTION | CONDENSER | | | | | |
|--------------------------------|------------------|---------|------------------|---------|------------------|---------|
| | Frame 1 | | Frame 2 | | Frame 3 | |
| | Standard Nozzles | Flanged | Standard Nozzles | Flanged | Standard Nozzles | Flanged |
| NIH, 1 Pass Cover, 150 psig | 177 | 204 | 260 | 297 | 260 | 297 |
| NIH, 2 Pass Cover, 150 psig | 185 | 218 | 265 | 318 | 265 | 318 |
| NIH, 3 Pass Cover, 150 psig | 180 | 196 | 272 | 288 | 272 | 288 |
| MWB End Cover, 150 psig | — | — | 234 | 234 | 234 | 234 |
| NIH/MWB Return Cover, 150 psig | 136 | 136 | 225 | 225 | 225 | 225 |
| NIH, 1 Pass Cover, 300 psig | 248 | 301 | 379 | 454 | 379 | 454 |
| NIH, 2 Pass Cover, 300 psig | 255 | 324 | 379 | 486 | 379 | 486 |
| NIH, 3 Pass Cover, 300 psig | 253 | 288 | 401 | 436 | 401 | 436 |
| NIH Plain End Cover, 300 psig | 175 | 175 | 270 | 270 | 270 | 270 |
| MWB End Cover, 300 psig | — | — | 474 | 474 | 474 | 474 |
| MWB Return Cover, 300 psig | — | — | 359 | 359 | 359 | 359 |

LEGEND

NIH — Nozzle-in-Head
MWB — Marine Waterbox

NOTE: Weight for NIH 2-pass cover, 150 psig, is included in the heat exchanger weights shown on pages 28-31.

Physical data (cont)



19XR,XRV WATERBOX COVER WEIGHTS — ENGLISH (lb) (cont) FRAMES 4, 5, AND 6; COOLER

| WATERBOX DESCRIPTION | COOLER | | | | | |
|--------------------------------|------------------|---------|------------------|---------|------------------|---------|
| | Frame 4 | | Frame 5 | | Frame 6 | |
| | Standard Nozzles | Flanged | Standard Nozzles | Flanged | Standard Nozzles | Flanged |
| NIH, 1 Pass Cover, 150 psig | 148 | 185 | 168 | 229 | 187 | 223 |
| NIH, 2 Pass Cover, 150 psig | 202 | 256 | 224 | 276 | 257 | 330 |
| NIH, 3 Pass Cover, 150 psig | 473 | 489 | 617 | 634 | 765 | 791 |
| MWB End Cover, 150 psig | 317 | 317 | 393 | 393 | 487 | 487 |
| NIH/MWB Return Cover, 150 psig | 138 | 138 | 154 | 154 | 172 | 172 |
| NIH, 1 Pass Cover, 300 psig | 633 | 709 | 764 | 839 | 978 | 1053 |
| NIH, 2 Pass Cover, 300 psig | 626 | 689 | 761 | 867 | 927 | 1078 |
| NIH, 3 Pass Cover, 300 psig | 660 | 694 | 795 | 830 | 997 | 1050 |
| NIH/MWB End Cover, 300 psig | 522 | 522 | 658 | 658 | 834 | 834 |

LEGEND

NIH — Nozzle-in-Head
MWB — Marine Waterbox

NOTE: Weight for NIH 2-pass cover, 150 psig, is included in the heat exchanger weights shown on pages 28-31.

FRAMES 4, 5, AND 6; CONDENSER

| WATERBOX DESCRIPTION | CONDENSER | | | | | |
|---|------------------|---------|------------------|---------|------------------|---------|
| | Frame 4 | | Frame 5 | | Frame 6 | |
| | Standard Nozzles | Flanged | Standard Nozzles | Flanged | Standard Nozzles | Flanged |
| NIH, 1 Pass Cover, 150 psig | 148 | 185 | 168 | 229 | 187 | 223 |
| NIH, 2 Pass Cover, 150 psig | 191 | 245 | 224 | 298 | 245 | 330 |
| NIH, 3 Pass Cover, 150 psig | 503 | 519 | 629 | 655 | 772 | 843 |
| MWB End Cover and Bolt-on End Cover, 150 psig | 317 | 317 | 393 | 393 | 487 | 487 |
| NIH/MWB Return Cover, 150 psig | 138 | 138 | 154 | 154 | 172 | 172 |
| NIH, 1 Pass Cover, 300 psig | 633 | 709 | 764 | 839 | 978 | 1053 |
| NIH, 2 Pass Cover, 300 psig | 622 | 729 | 727 | 878 | 923 | 1074 |
| NIH, 3 Pass Cover, 300 psig | 655 | 689 | 785 | 838 | 995 | 1049 |
| NIH/MWB End Cover, 300 psig | 522 | 522 | 658 | 658 | 834 | 834 |

LEGEND

NIH — Nozzle-in-Head
MWB — Marine Waterbox

NOTE: Weight for NIH 2-pass cover, 150 psig, is included in the heat exchanger weights shown on pages 28-31.

19XR,XRV WATERBOX COVER WEIGHTS — ENGLISH (lb) (cont)
FRAMES 7 AND 8; COOLER

| WATERBOX DESCRIPTION | COOLER | | | |
|--------------------------------|------------------|---------|------------------|---------|
| | Frame 7 | | Frame 8 | |
| | Standard Nozzles | Flanged | Standard Nozzles | Flanged |
| NIH, 1 Pass Cover, 150 psig | 329 | 441 | 417 | 494 |
| NIH, 2 Pass Cover, 150 psig | 426 | 541 | 540 | 693 |
| NIH, 3 Pass Cover, 150 psig | 1250 | 1291 | 1629 | 1687 |
| MWB End Cover, 150 psig | 844 | 844 | 1125 | 1125 |
| NIH/MWB Return Cover, 150 psig | 315 | 315 | 404 | 404 |
| NIH, 1 Pass Cover, 300 psig | 1712 | 1883 | 2359 | 2523 |
| NIH, 2 Pass Cover, 300 psig | 1662 | 1908 | 2369 | 2599 |
| NIH, 3 Pass Cover, 300 psig | 1724 | 1807 | 2353 | 2516 |
| NIH/MWB End Cover, 300 psig | 1378 | 1378 | 1951 | 1951 |

LEGEND

NIH — Nozzle-in-Head
MWB — Marine Waterbox

NOTE: Weight for NIH 2-pass cover, 150 psig, is included in the heat exchanger weights shown on pages 28-31.

FRAMES 7 AND 8; CONDENSER

| WATERBOX DESCRIPTION | CONDENSER | | | |
|---------------------------------|------------------|---------|------------------|---------|
| | Frame 7 | | Frame 8 | |
| | Standard Nozzles | Flanged | Standard Nozzles | Flanged |
| NIH, 1 Pass Cover, 150 psig | 329 | 441 | 417 | 494 |
| NIH, 2 Pass Cover, 150 psig | 404 | 520 | 508 | 662 |
| NIH, 3 Pass Cover, 150 psig | 1222 | 1280 | 1469 | 1527 |
| MWB End Cover, 150 psig | 781 | 781 | 1007 | 1007 |
| Bolt-on MWB End Cover, 150 psig | 700 | 700 | 1307 | 1307 |
| NIH/MWB Return Cover, 150 psig | 315 | 315 | 404 | 404 |
| NIH, 1 Pass Cover, 300 psig | 1690 | 1851 | 1986 | 2151 |
| NIH, 2 Pass Cover, 300 psig | 1628 | 1862 | 1893 | 2222 |
| NIH, 3 Pass Cover, 300 psig | 1714 | 1831 | 1993 | 2112 |
| NIH/MWB End Cover, 300 psig | 1276 | 1276 | 1675 | 1675 |

LEGEND

NIH — Nozzle-in-Head
MWB — Marine Waterbox

NOTE: Weight for NIH 2-pass cover, 150 psig, is included in the heat exchanger weights shown on pages 28-31.

Physical data (cont)



19XR,XRV WATERBOX COVER WEIGHTS — ENGLISH (lb) (cont) TWO-STAGE COMPRESSOR FRAME 6; COOLER FRAME A

| WATERBOX DESCRIPTION | PASSES | COOLER | |
|---|--------|------------------|---------|
| | | FRAME A | |
| | | STANDARD NOZZLES | FLANGED |
| Dished Head, 150 psig | 1 | 1006 | 1171 |
| MWB End Cover, 150 psig | 1 | 976 | 976 |
| MWB End Cover (ASME), 300 psig | 1 | 2460 | 2460 |
| Dished Head, 150 psig | 2 | 1140 | 1336 |
| Dished Head (Return Cover), 150 psig | 2 | 976 | 976 |
| MWB End Cover, 150 psig | 2 | 1068 | 1068 |
| MWB End Cover (Return Cover), 150 psig | 2 | 976 | 976 |
| MWB End Cover (ASME), 300 psig | 2 | 2460 | 2460 |
| MWB End Cover (ASME) (Return Cover), 300 psig | 2 | 2460 | 2460 |
| Dished Head, 150 psig | 3 | 1048 | 1112 |
| MWB End Cover, 150 psig | 3 | 1030 | 1030 |
| MWB End Cover (ASME), 300 psig | 3 | 2460 | 2460 |

LEGEND

ASME — American Society of Mechanical Engineers
MWB — Marine Waterbox

NOTES:

1. Consult factory for 1 and 3 pass data.
2. Weight for dished head cover is included in the heat exchanger weights shown on pages 32-35.
3. 2 pass weight difference is due to division plate.

TWO-STAGE COMPRESSOR FRAME 6; CONDENSER FRAME A AND B

| WATERBOX DESCRIPTION | PASSES | CONDENSER | | | |
|--------------------------------------|--------|------------------|---------|------------------|---------|
| | | FRAME A | | FRAME B | |
| | | STANDARD NOZZLES | FLANGED | STANDARD NOZZLES | FLANGED |
| Dished Head, 150 psig | 1 | 895 | 1060 | 1006 | 1171 |
| MWB, 150 psig | 1 | 859 | 859 | 1075 | 1075 |
| MWB (ASME), 300 psig | 1 | 2117 | 2117 | 2744 | 2744 |
| Dished Head, 150 psig | 2 | 981 | 1179 | 1140 | 1400 |
| Dished Head (Return Cover), 150 psig | 2 | 824 | 824 | 976 | 976 |
| MWB 150 psig | 2 | 907 | 907 | 1075 | 1075 |
| MWB (Return), 150 psig | 2 | 824 | 824 | 976 | 976 |
| MWB (ASME), 300 psig | 2 | 2117 | 2117 | 2744 | 2744 |
| MWB Return Cover (ASME), 300 psig | 2 | 2117 | 2117 | 2744 | 2744 |
| Dished Head, 150 psig | 3 | 1067 | 1157 | 1050 | 1140 |
| MWB End Cover, 150 psig | 3 | 942 | 942 | 1020 | 1020 |
| MWB End Cover (ASME), 300 psig | 3 | 2117 | 2177 | 2744 | 2744 |

LEGEND

ASME — American Society of Mechanical Engineers
MWB — Marine Waterbox

NOTES:

1. Consult factory for 1 and 3 pass data.
2. Weight for dished head cover is included in the heat exchanger weights shown on pages 32-35.
3. 2 pass weight difference is due to division plate.

19XR,XRV WATERBOX COVER WEIGHTS — ENGLISH (lb) (cont)
TWO-STAGE COMPRESSOR FRAME 7; COOLER FRAMES B, C

| WATERBOX DESCRIPTION | PASSES | COOLER | | | |
|--------------------------------------|--------|------------------|---------|------------------|---------|
| | | FRAME B | | FRAME C | |
| | | STANDARD NOZZLES | FLANGED | STANDARD NOZZLES | FLANGED |
| Dished Head, 150 psig | 1 | 1380 | 1545 | 1849 | 2014 |
| MWB End Cover, 150 psig | 1 | 1366 | 1366 | 1835 | 1835 |
| MWB End Cover (ASME), 300 psig | 1 | 3425 | 3425 | 4805 | 4805 |
| Dished Head, 150 psig | 2 | 1589 | 1849 | 2076 | 2336 |
| Dished Head (Return Cover), 150 psig | 2 | 1367 | 1367 | 1836 | 1836 |
| MWB End Cover, 150 psig | 2 | 1489 | 1489 | 1987 | 1987 |
| MWB (Return Cover), 150 psig | 2 | 1367 | 1367 | 1836 | 1836 |
| MWB End Cover (ASME), 300 psig | 2 | 3425 | 3425 | 4805 | 4805 |
| MWB (Return Cover), 300 psig | 2 | 3425 | 3425 | 4805 | 4805 |
| Dished Head, 150 psig | 3 | 1514 | 1604 | 2028 | 2118 |
| MWB End Cover, 150 psig | 3 | 1506 | 1506 | 1995 | 1995 |
| MWB End Cover (ASME), 300 psig | 3 | 3425 | 3425 | 4805 | 4805 |

LEGEND

ASME — American Society of Mechanical Engineers
MWB — Marine Waterbox

NOTES:

1. Consult factory for 1 and 3 pass data.
2. Weight for dished head cover is included in the heat exchanger weights shown on pages 32-35.
3. 2 pass weight difference is due to division plate.

TWO-STAGE COMPRESSOR FRAME 7; CONDENSER FRAMES C, D

| WATERBOX DESCRIPTION | PASSES | CONDENSER | | | |
|--------------------------------------|--------|------------------|---------|------------------|---------|
| | | FRAME C | | FRAME D | |
| | | STANDARD NOZZLES | FLANGED | STANDARD NOZZLES | FLANGED |
| Dished Head, 150 psi | 1 | 1380 | 1600 | 1849 | 2029 |
| MWB End Cover, 150 psi | 1 | 1367 | 1367 | 1835 | 1835 |
| MWB End Cover (ASME), 300 psi | 1 | 3639 | 3639 | 5249 | 5249 |
| Dished Head, 150 psig | 2 | 1589 | 1919 | 2076 | 2406 |
| Dished Head (Return Cover), 150 psig | 2 | 1367 | 1367 | 1836 | 1836 |
| MWB End Cover, 150 psig | 2 | 1497 | 1497 | 1988 | 1988 |
| MWB (Return Cover), 150 psi | 2 | 1367 | 1367 | 1836 | 1836 |
| MWB End Cover (ASME), 300 psig | 2 | 3639 | 3639 | 5249 | 5249 |
| MWB (Return Cover) (ASME), 300 psig | 2 | 3639 | 3639 | 5249 | 5249 |
| Dished Head, 150 psi | 3 | 1514 | 1612 | 2028 | 2126 |
| MWB End Cover, 150 psig | 3 | 1493 | 1493 | 1993 | 1993 |
| MWB End Cover (ASME), 300 psig | 3 | 3639 | 3639 | 5249 | 5249 |

LEGEND

ASME — American Society of Mechanical Engineers
MWB — Marine Waterbox

NOTES:

1. Consult factory for 1 and 3 pass data.
2. Weight for dished head cover is included in the heat exchanger weights shown on pages 32-35.
3. 2 pass weight difference is due to division plate.

Physical data (cont)



19XR,XRV WATERBOX COVER WEIGHTS — SI (kg) FRAMES 1, 2, 3; COOLER

| WATERBOX DESCRIPTION | COOLER | | | | | |
|--------------------------------|------------------|---------|------------------|---------|------------------|---------|
| | Frame 1 | | Frame 2 | | Frame 3 | |
| | Standard Nozzles | Flanged | Standard Nozzles | Flanged | Standard Nozzles | Flanged |
| NIH, 1 Pass Cover, 1034 kPa | 80 | 92 | 130 | 144 | 130 | 144 |
| NIH, 2 Pass Cover, 1034 kPa | 84 | 99 | 130 | 154 | 130 | 154 |
| NIH, 3 Pass Cover, 1034 kPa | 82 | 88 | 133 | 141 | 133 | 141 |
| MWB End Cover, 1034 kPa | — | — | 143 | 143 | 143 | 143 |
| NIH/MWB Return Cover, 1034 kPa | 62 | 62 | 110 | 110 | 110 | 110 |
| NIH, 1 Pass Cover, 2068 kPa | 112 | 137 | 186 | 220 | 186 | 220 |
| NIH, 2 Pass Cover, 2068 kPa | 116 | 147 | 186 | 235 | 186 | 235 |
| NIH, 3 Pass Cover, 2068 kPa | 115 | 131 | 196 | 212 | 196 | 212 |
| NIH Plain End Cover, 2068 kPa | 79 | 79 | 132 | 132 | 132 | 132 |
| MWB End Cover, 2068 kPa | — | — | 281 | 281 | 281 | 281 |
| MWB Return Cover, 2068 kPa | — | — | 202 | 202 | 202 | 202 |

LEGEND

NIH — Nozzle-in-Head
MWB — Marine Waterbox

NOTE: Weight for NIH 2-pass cover, 1034 kPa, is included in the heat exchanger weights shown on pages 28-31.

FRAMES 1, 2, 3; CONDENSER

| WATERBOX DESCRIPTION | CONDENSER | | | | | |
|--------------------------------|------------------|---------|------------------|---------|------------------|---------|
| | Frame 1 | | Frame 2 | | Frame 3 | |
| | Standard Nozzles | Flanged | Standard Nozzles | Flanged | Standard Nozzles | Flanged |
| NIH, 1 Pass Cover, 1034 kPa | 80 | 92 | 118 | 135 | 118 | 135 |
| NIH, 2 Pass Cover, 1034 kPa | 84 | 99 | 120 | 144 | 120 | 144 |
| NIH, 3 Pass Cover, 1034 kPa | 82 | 88 | 123 | 131 | 123 | 131 |
| MWB End Cover, 1034 kPa | — | — | 106 | 106 | 106 | 106 |
| NIH/MWB Return Cover, 1034 kPa | 62 | 62 | 102 | 102 | 102 | 102 |
| NIH, 1 Pass Cover, 2068 kPa | 112 | 137 | 172 | 206 | 172 | 206 |
| NIH, 2 Pass Cover, 2068 kPa | 116 | 147 | 172 | 220 | 172 | 220 |
| NIH, 3 Pass Cover, 2068 kPa | 115 | 131 | 182 | 198 | 182 | 198 |
| NIH Plain End Cover, 2068 kPa | 79 | 79 | 122 | 122 | 122 | 122 |
| MWB End Cover, 2068 kPa | — | — | 215 | 215 | 215 | 215 |
| MWB Return Cover, 2068 kPa | — | — | 163 | 163 | 163 | 163 |

LEGEND

NIH — Nozzle-in-Head
MWB — Marine Waterbox

NOTE: Weight for NIH 2-pass cover, 1034 kPa, is included in the heat exchanger weights shown on pages 28-31.

19XR,XRV WATERBOX COVER WEIGHTS — SI (kg) (cont)
FRAMES 4, 5, 6; COOLER

| WATERBOX DESCRIPTION | COOLER | | | | | |
|--------------------------------|------------------|---------|------------------|---------|------------------|---------|
| | Frame 4 | | Frame 5 | | Frame 6 | |
| | Standard Nozzles | Flanged | Standard Nozzles | Flanged | Standard Nozzles | Flanged |
| NIH, 1 Pass Cover, 1034 kPa | 67 | 84 | 76 | 104 | 85 | 101 |
| NIH, 2 Pass Cover, 1034 kPa | 92 | 116 | 102 | 125 | 117 | 150 |
| NIH, 3 Pass Cover, 1034 kPa | 215 | 222 | 280 | 288 | 347 | 359 |
| MWB End Cover, 1034 kPa | 144 | 144 | 178 | 178 | 221 | 221 |
| NIH/MWB Return Cover, 1034 kPa | 63 | 63 | 70 | 70 | 78 | 78 |
| NIH, 1 Pass Cover, 2068 kPa | 287 | 322 | 347 | 381 | 444 | 478 |
| NIH, 2 Pass Cover, 2068 kPa | 284 | 313 | 345 | 394 | 420 | 489 |
| NIH, 3 Pass Cover, 2068 kPa | 299 | 315 | 361 | 376 | 452 | 476 |
| NIH/MWB End Cover, 2068 kPa | 237 | 237 | 298 | 298 | 378 | 378 |

LEGEND

NIH — Nozzle-in-Head
MWB — Marine Waterbox

NOTE: Weight for NIH 2-pass cover, 1034 kPa, is included in the heat exchanger weights shown on pages 28-31.

FRAMES 4, 5, 6; CONDENSER

| WATERBOX DESCRIPTION | CONDENSER | | | | | |
|---|------------------|---------|------------------|---------|------------------|---------|
| | Frame 4 | | Frame 5 | | Frame 6 | |
| | Standard Nozzles | Flanged | Standard Nozzles | Flanged | Standard Nozzles | Flanged |
| NIH, 1 Pass Cover, 1034 kPa | 67 | 84 | 76 | 104 | 85 | 101 |
| NIH, 2 Pass Cover, 1034 kPa | 87 | 111 | 102 | 135 | 111 | 150 |
| NIH, 3 Pass Cover, 1034 kPa | 228 | 235 | 285 | 297 | 350 | 382 |
| MWB End Cover and Bolt-on End Cover, 1034 kPa | 144 | 144 | 178 | 178 | 221 | 221 |
| NIH/MWB Return Cover, 1034 kPa | 63 | 63 | 70 | 70 | 78 | 78 |
| NIH, 1 Pass Cover, 2068 kPa | 287 | 322 | 347 | 381 | 444 | 478 |
| NIH, 2 Pass Cover, 2068 kPa | 282 | 331 | 330 | 393 | 419 | 487 |
| NIH, 3 Pass Cover, 2068 kPa | 297 | 313 | 356 | 376 | 451 | 476 |
| NIH/MWB End Cover, 2068 kPa | 237 | 237 | 298 | 298 | 378 | 378 |

LEGEND

NIH — Nozzle-in-Head
MWB — Marine Waterbox

NOTE: Weight for NIH 2-pass cover, 1034 kPa, is included in the heat exchanger weights shown on pages 28-31.

Physical data (cont)



19XR,XRV WATERBOX COVER WEIGHTS — SI (kg) (cont) FRAMES 7 AND 8; COOLER

| WATERBOX DESCRIPTION | COOLER | | | |
|--------------------------------|------------------|---------|------------------|---------|
| | Frame 7 | | Frame 8 | |
| | Standard Nozzles | Flanged | Standard Nozzles | Flanged |
| NIH, 1 Pass Cover, 1034 kPa | 149 | 200 | 189 | 224 |
| NIH, 2 Pass Cover, 1034 kPa | 193 | 245 | 245 | 314 |
| NIH, 3 Pass Cover, 1034 kPa | 567 | 586 | 739 | 765 |
| MWB End Cover, 1034 kPa | 383 | 383 | 510 | 510 |
| NIH/MWB Return Cover, 1034 kPa | 143 | 143 | 183 | 183 |
| NIH, 1 Pass Cover, 2068 kPa | 777 | 854 | 1070 | 1144 |
| NIH, 2 Pass Cover, 2068 kPa | 754 | 865 | 1075 | 1179 |
| NIH, 3 Pass Cover, 2068 kPa | 782 | 820 | 1067 | 1141 |
| NIH/MWB End Cover, 2068 kPa | 625 | 625 | 885 | 885 |

LEGEND

NIH — Nozzle-in-Head
MWB — Marine Waterbox

NOTE: Weight for NIH 2-pass cover, 1034 kPa, is included in the heat exchanger weights shown on pages 28-31.

FRAMES 7 AND 8; CONDENSER

| WATERBOX DESCRIPTION | CONDENSER | | | |
|---------------------------------|------------------|---------|------------------|---------|
| | Frame 7 | | Frame 8 | |
| | Standard Nozzles | Flanged | Standard Nozzles | Flanged |
| NIH, 1 Pass Cover, 1034 kPa | 149 | 200 | 189 | 224 |
| NIH, 2 Pass Cover, 1034 kPa | 183 | 236 | 230 | 300 |
| NIH, 3 Pass Cover, 1034 kPa | 554 | 580 | 666 | 693 |
| MWB End Cover, 1034 kPa | 354 | 354 | 457 | 457 |
| Bolt-on MWB End Cover, 1034 kPa | 318 | 318 | 593 | 593 |
| NIH/MWB Return Cover, 1034 kPa | 143 | 143 | 183 | 183 |
| NIH, 1 Pass Cover, 2068 kPa | 767 | 840 | 901 | 976 |
| NIH, 2 Pass Cover, 2068 kPa | 738 | 845 | 859 | 1008 |
| NIH, 3 Pass Cover, 2068 kPa | 777 | 831 | 904 | 958 |
| NIH/MWB End Cover, 2068 kPa | 579 | 579 | 760 | 760 |

LEGEND

NIH — Nozzle-in-Head
MWB — Marine Waterbox

NOTE: Weight for NIH 2-pass cover, 1034 kPa, is included in the heat exchanger weights shown on pages 28-31.

19XR,XRV WATERBOX COVER WEIGHTS — SI (kg) (cont)
TWO-STAGE COMPRESSOR FRAME 6; COOLER FRAME A

| WATERBOX DESCRIPTION | PASSES | COOLER | |
|---|--------|------------------|---------|
| | | FRAME A | |
| | | STANDARD NOZZLES | FLANGED |
| Dished Head, 150 psig | 1 | 456 | 531 |
| MWB End Cover, 150 psig | 1 | 443 | 443 |
| MWB End Cover (ASME), 300 psig | 1 | 1116 | 1116 |
| Dished Head, 150 psig | 2 | 517 | 606 |
| Dished Head (Return Cover), 150 psig | 2 | 443 | 443 |
| MWB End Cover, 150 psig | 2 | 484 | 484 |
| MWB End Cover (Return Cover), 150 psig | 2 | 443 | 443 |
| MWB End Cover (ASME), 300 psig | 2 | 1116 | 1116 |
| MWB End Cover (ASME) (Return Cover), 300 psig | 2 | 1116 | 1116 |
| Dished Head, 150 psig | 3 | 475 | 504 |
| MWB End Cover, 150 psig | 3 | 467 | 467 |
| MWB End Cover (ASME), 300 psig | 3 | 1116 | 1116 |

LEGEND

ASME — American Society of Mechanical Engineers
MWB — Marine Waterbox

NOTES:

1. Consult factory for 1 and 3 pass data.
2. Weight for dished head cover is included in the heat exchanger weights shown on pages 32-35.
3. 2 pass weight difference is due to division plate.

TWO-STAGE COMPRESSOR FRAME 6; CONDENSER FRAMES A, B

| WATERBOX DESCRIPTION | PASSES | CONDENSER | | | |
|--------------------------------------|--------|------------------|---------|------------------|---------|
| | | FRAME A | | FRAME B | |
| | | STANDARD NOZZLES | FLANGED | STANDARD NOZZLES | FLANGED |
| Dished Head, 150 psig | 1 | 406 | 481 | 473 | 547 |
| MWB, 150 psig | 1 | 390 | 390 | 488 | 488 |
| MWB (ASME), 300 psig | 1 | 960 | 960 | 1292 | 1292 |
| Dished Head, 150 psig | 2 | 445 | 535 | 574 | 633 |
| Dished Head (Return Cover), 150 psig | 2 | 374 | 374 | 481 | 481 |
| MWB 150 psig | 2 | 411 | 411 | 630 | 630 |
| MWB End Cover, 150 psig | 2 | 374 | 411 | 488 | 488 |
| MWB (ASME), 300 psig | 2 | 960 | 1083 | 1440 | 1440 |
| MWB Return Cover (ASME), 300 psig | 2 | 960 | 960 | 1245 | 1245 |
| Dished Head, 150 psig | 3 | 484 | 525 | 476 | 517 |
| MWB End Cover, 150 psig | 3 | 427 | 427 | 463 | 463 |
| MWB End Cover (ASME), 300 psig | 3 | 960 | 987 | 1245 | 1245 |

LEGEND

ASME — American Society of Mechanical Engineers
MWB — Marine Waterbox

NOTES:

1. Consult factory for 1 and 3 pass data.
2. Weight for dished head cover is included in the heat exchanger weights shown on pages 32-35.
3. 2 pass weight difference is due to division plate.

Physical data (cont)



19XR, XRV WATERBOX COVER WEIGHTS — SI (kg) (cont) TWO-STAGE COMPRESSOR FRAME 7; COOLER FRAMES B, C

| WATERBOX DESCRIPTION | PASSES | COOLER | | | |
|--------------------------------------|--------|------------------|---------|------------------|---------|
| | | FRAME B | | FRAME C | |
| | | STANDARD NOZZLES | FLANGED | STANDARD NOZZLES | FLANGED |
| Dished Head, 1034 kPa | 1 | 626 | 701 | 839 | 914 |
| MWB End Cover, 1034 kPa | 1 | 620 | 620 | 832 | 832 |
| MWB End Cover (ASME), 2068 kPa | 1 | 1554 | 1554 | 2180 | 2180 |
| Dished Head, 1034 kPa | 2 | 721 | 839 | 942 | 1060 |
| Dished Head (Return Cover), 1034 kPa | 2 | 620 | 620 | 833 | 833 |
| MWB End Cover, 1034 kPa | 2 | 675 | 675 | 901 | 901 |
| MWB (Return Cover), 1034 kPa | 2 | 620 | 620 | 833 | 833 |
| MWB End Cover (ASME), 2068 kPa | 2 | 1554 | 1554 | 2180 | 2180 |
| MWB (Return Cover), 2068 kPa | 2 | 1554 | 1554 | 2180 | 2180 |
| Dished Head, 1034 kPa | 3 | 687 | 728 | 920 | 961 |
| MWB End Cover, 1034 kPa | 3 | 683 | 683 | 905 | 905 |
| MWB End Cover (ASME), 2068 kPa | 3 | 1554 | 1554 | 2180 | 2180 |

LEGEND

ASME — American Society of Mechanical Engineers
MWB — Marine Waterbox

NOTES:

1. Consult factory for 1 and 3 pass data.
2. Weight for dished head cover is included in the heat exchanger weights shown on pages 32-35.
3. 2 pass weight difference is due to division plate.

TWO-STAGE COMPRESSOR FRAME 7; CONDENSER FRAMES C, D

| WATERBOX DESCRIPTION | PASSES | CONDENSER | | | |
|--------------------------------------|--------|------------------|---------|------------------|---------|
| | | FRAME C | | FRAME D | |
| | | STANDARD NOZZLES | FLANGED | STANDARD NOZZLES | FLANGED |
| Dished Head, 150 psi | 1 | 626 | 726 | 839 | 920 |
| MWB End Cover, 150 psi | 1 | 620 | 620 | 832 | 832 |
| MWB End Cover (ASME), 300 psi | 1 | 1651 | 1651 | 2353 | 2353 |
| Dished Head, 150 psig | 2 | 721 | 870 | 942 | 1091 |
| Dished Head (Return Cover), 150 psig | 2 | 620 | 620 | 833 | 833 |
| MWB End Cover, 150 psig | 2 | 679 | 679 | 902 | 902 |
| MWB (Return Cover), 150 psi | 2 | 620 | 620 | 833 | 833 |
| MWB End Cover (ASME), 300 psig | 2 | 1651 | 1651 | 2381 | 2381 |
| MWB (Return Cover) (ASME), 300 psig | 2 | 1651 | 1651 | 2381 | 2381 |
| Dished Head, 150 psi | 3 | 687 | 731 | 920 | 964 |
| MWB End Cover, 150 psig | 3 | 677 | 677 | 904 | 904 |
| MWB End Cover (ASME), 300 psig | 3 | 1651 | 1651 | 2381 | 2381 |

LEGEND

ASME — American Society of Mechanical Engineers
MWB — Marine Waterbox

NOTES:

1. Consult factory for 1 and 3 pass data.
2. Weight for dished head cover is included in the heat exchanger weights shown on pages 32-35.
3. 2 pass weight difference is due to division plate.

Options and accessories



| ITEM | OPTION (FACTORY INSTALLED) | ACCESSORY (FIELD INSTALLED) |
|---|----------------------------|-----------------------------|
| Unit-Mounted Variable Frequency Drive (Available for Low Voltage Only) | X | |
| Free-Standing Low Voltage Variable Frequency Drive | | X |
| Free-Standing Medium Voltage Variable Frequency Drive | | X |
| Free-Standing Starter | X | |
| Unit-Mounted Low-Voltage Wye-Delta or Solid-State Starters (Available on Heat Exchanger Frame Sizes 1 to 7 Only) | X | |
| Shipped Factory Charged with Refrigerant (can be shipped separate) | X | |
| One, 2, or 3 Pass Cooler or Condenser Water-side Construction | X | |
| Hot Gas Bypass | X | |
| Thermal Insulation (Except Waterbox Covers) | X | |
| Nozzle-in Head Waterbox, 300 psig (2068 kPa) | X | |
| Marine Waterboxes, 150 psig (1034 kPa)* | X | |
| Marine Waterboxes, 300 psig (2068 kPa), ASME Certified* | X | |
| Marine Bolt-on Waterboxes for Condenser, 150 psig (1034 kPa) with Titanium-Clad Tubesheets (Available on Condenser Frame Sizes 4 to 8 Only) | X | |
| Flanged Cooler and/or Condenser Waterbox Nozzles† | X | |
| Waterbox Hinges | X | |
| Zinc Anodes | X | |
| 0.028 or 0.035 in. (0.711 or 0.889 mm) Internally/Externally Enhanced Copper Tubing — Cooler/Condenser | X | |
| 0.028 or 0.035 in. (0.711 or 0.889 mm) Smooth Bore/Externally Enhanced Copper Tubing — Cooler/Condenser | X | |
| 0.028 or 0.035 in. (0.711 or 0.889 mm) Smooth Bore/Externally Enhanced Cupronickel Tubing — Cooler/Condenser | X | |
| 0.028 or 0.035 in. (0.711 or 0.889 mm) Internally/Externally Enhanced Cupronickel Tubing — Cooler/Condenser | X | |
| 0.025 or 0.028 in. (0.635 or 0.711 mm) Wall Tubes, Titanium, Internally Enhanced — Condenser | X | |
| Export Crating | X | |
| Customer Factory Performance Testing | X | |
| Extended Warranty (North America only) | X | |
| Service Contract | X | |
| Refrigerant Isolation Valves | X | |
| Unit-Mounted Pumpout Unit (Available on Heat Exchanger Frames Sizes 2 to 5, E Only) | X | |
| Seismic Kit (Select Models) | X | |
| Stand-Alone Pumpout Unit | | X |
| Separate Storage Tank and Pumpout Unit | | X |
| Soleplate Package | | X |
| Multiple Chiller System Remote Temperature Sensor | | X |
| BACnet** Communication Option (Compressor Frames 2 to 5, E, BACnet over MS/TP) | X | |
| BACnet** Communication Option (Compressor Frames 6 and 7) | X | |
| BACnet** Carrier Translator (Compressor Frames 2 to 5, E) | | X |
| LonWorks†† Carrier Translator (Compressor Frames 2 to 5, E) | | X |
| Discharge Line Sound Reduction Kit (Compressor Frames 2 to 5, E) | | X |
| Acoustical Sound Insulation Kit (Compressor Frames 2 to 5, E) | | X |
| Spring Isolator Kit | | X |

*Optional marine waterboxes are available for 19XR heat exchanger frames 2-8 and 19XR two-stage compressors frame sizes 6 and 7, heat exchanger frame sizes A, B, C, and D. Standard waterboxes for both 19XR and 19XRV chillers are nozzle-in-head type, 150 psig (1034 kPa). †Standard waterbox nozzles are Victaulic type. Flanged nozzles are available as an option with either nozzle-in-head type waterboxes or marine waterboxes.

**Sponsored by ASHRAE (American Society of Heating, Refrigerating, and Air-Conditioning Engineers) (English units of measure only).

††Registered trademark of Echelon corporation.

NOTE: The BACnet option for 19XR Compressor Frames 6 and 7 (PIC 5 controls) provides BACnet over IP communication only. This option disables CCN communication and i-Vu® considers this option to be a third-party device. For higher levels of integration, contact your local Carrier Controls office.

Options and accessories (cont)



UNIT-MOUNTED STARTER AND VFD FEATURES AND OPTIONS*

| ITEM | WYE-DELTA | SOLID STATE | VFD |
|---|-----------|-------------|-----|
| ISM | S | N/A | S |
| Branch Oil Pump Circuit Breaker | S | S | S |
| Controls/Oil Heater Transformer with Branch Circuit Breaker | S | S | S |
| Microprocessor Based Overload Trip Protection | S | S | S |
| Main Power Disconnect (Non-Fused Type) | S | N/A | N/A |
| Main Power Circuit Breaker | N/A | S | S |
| High Interrupt Capacity Main Circuit Breaker | O | O | O |
| Phase Loss/Reversal Imbalance Protection | S | S | S |
| Three Phase Ground Fault Protection† | O | O | S |
| Integral SCR Bypass Contactor | N/A | S | N/A |
| Three-Phase Ammeter | O | O | N/A |
| Three-Phase Voltmeter | O | O | N/A |
| Three-Phase Over/Under Voltage Protection | S | S | S |
| Power Factor Digital Display | S | S | S |
| Frequency Digital Display | S | S | S |
| Digital Watt Display | O | O | O |
| Digital Watt Hour Display | O | O | O |
| Digital Power Factor Display | O | O | O |
| Demand Kilowatt Display | O | O | O |
| Lightning Arrestor and Surge Capacitor Package | O | O | N/A |
| Power Factor Correction Capacitors | O | O | N/A |

LEGEND

ISM — Integrated Starter Module
N/A — Not Applicable
O — Optional
S — Standard Feature
SCR — Silicon Control Rectifier
VFD — Variable Frequency Drive

*For free-standing starters, refer to the E-CAT Free Standing Starters builder software. Refer to the E-CAT Chiller builder software for all VFD options, as some options may not be available for all VFD models.

†Low voltage: phase to phase and phase to ground. Medium voltage: phase to phase and phase to ground.

Dimensions



19XR,XRV DIMENSIONS (Nozzle-in-Head Waterbox)

| HEAT EXCHANGER SIZE | A (Length, with Nozzle-in-Head Waterbox) | | | | | | 19XR B (Width) | | 19XR C (Height) | | 19XRV B (Width) | | 19XRV C (Height) |
|-----------------------|--|------|------------------------------------|------|------------------------------------|------|-----------------------------------|------|----------------------------------|------|------------------------------------|------|------------------|
| | 1-Pass | | 2-Pass* | | 3-Pass | | ft-in. | mm | ft-in. | mm | ft-in. | mm | |
| | ft-in. | mm | ft-in. | mm | ft-in. | mm | | | | | | | |
| 10 to 12 | 11- 11 | 3632 | 11- 4 | 3464 | 11- 11 | 3632 | 5- 2 ⁷ / ₈ | 1597 | 6- 1 ¹ / ₄ | 1861 | 5- 2 ⁷ / ₈ | 1597 | |
| 15 to 17 | 14- 2 ¹ / ₂ | 4331 | 13- 7 ¹ / ₂ | 4163 | 14- 2 ¹ / ₂ | 4331 | 5- 2 ⁷ / ₈ | 1597 | 6- 1 ¹ / ₄ | 1861 | 5- 2 ⁷ / ₈ | 1597 | |
| 20 to 22 | 12- 0 ¹ / ₂ | 3670 | 11- 5 ¹ / ₈ | 3483 | 12- 0 ¹ / ₂ | 3670 | 5- 6 ⁷ / ₁₆ | 1688 | 6- 3 ¹ / ₄ | 1911 | 5- 6 ⁷ / ₁₆ | 1688 | |
| 30 to 32† | 14- 4 | 4369 | 13- 8 ⁵ / ₈ | 4182 | 14- 4 | 4369 | 5- 7 ³ / ₁₆ | 1707 | 6- 9 ⁵ / ₈ | 2073 | 5- 6 ⁷ / ₁₆ | 1688 | |
| 30 to 32** | 14- 4 | 4369 | 13- 8 ⁵ / ₈ | 4182 | 14- 4 | 4369 | 5- 7 ³ / ₁₆ | 1707 | 6- 9 ⁵ / ₈ | 2073 | 5- 6 ¹ / ₈ | 1680 | |
| 35 to 37† | 16- 0 ¹ / ₂ | 4889 | 15- 5 ¹ / ₈ | 4703 | 16- 0 ¹ / ₂ | 4889 | 5- 7 ³ / ₁₆ | 1707 | 6- 9 ⁵ / ₈ | 2073 | 5- 6 ⁷ / ₁₆ | 1688 | |
| 35 to 37** | 16- 0 ¹ / ₂ | 4889 | 15- 5 ¹ / ₈ | 4703 | 16- 0 ¹ / ₂ | 4889 | 5- 7 ³ / ₁₆ | 1707 | 6- 9 ⁵ / ₈ | 2073 | 5- 6 ¹ / ₈ | 1680 | |
| 40 to 42 | 14- 10 | 4521 | 14- 3 ⁵ / ₈ | 4360 | 14- 6 ³ / ₄ | 4439 | 6- 3 ¹ / ₈ | 1908 | 7- 0 ³ / ₄ | 2153 | 6- 2 | 1880 | |
| 45 to 47 | 16- 6 ¹ / ₂ | 5042 | 16- 0 ¹ / ₈ | 4880 | 16- 3 ¹ / ₄ | 4959 | 6- 3 ¹ / ₈ | 1908 | 7- 0 ³ / ₄ | 2153 | 6- 2 | 1880 | |
| 50 to 52** | 14- 11 | 4546 | 14- 5 | 4395 | 14- 7 ¹ / ₄ | 4451 | 6- 8 ⁷ / ₈ | 2054 | 7- 2 ³ / ₈ | 2194 | 6- 6 ¹ / ₂ | 1994 | |
| 50 to 54, 5K to 5R†† | 14- 11 | 4546 | 14- 5 | 4395 | 14- 7 ¹ / ₄ | 4451 | 6- 8 ⁷ / ₈ | 2054 | 7- 2 ³ / ₈ | 2194 | 6- 7 ⁷ / ₈ | 2029 | |
| 5A to 5C | 14- 11 | 4546 | 14- 5 | 4395 | 14- 7 ¹ / ₄ | 4451 | 6- 8 ⁷ / ₈ | 2054 | 7- 2 ³ / ₈ | 2194 | 6- 8 ⁷ / ₈ | 2054 | |
| 55 to 57** | 16- 7 ¹ / ₂ | 5067 | 16- 1 ¹ / ₂ | 4915 | 16- 3 ³ / ₄ | 4972 | 6- 8 ⁷ / ₈ | 2054 | 7- 2 ³ / ₈ | 2194 | 6- 6 ¹ / ₂ | 1994 | |
| 55 to 59, 5T to 5Z†† | 16- 7 ¹ / ₂ | 5067 | 16- 1 ¹ / ₂ | 4915 | 16- 3 ³ / ₄ | 4972 | 6- 8 ⁷ / ₈ | 2054 | 7- 2 ³ / ₈ | 2194 | 6- 7 ⁷ / ₈ | 2029 | |
| 5F to 5H | 16- 7 ¹ / ₂ | 5067 | 16- 1 ¹ / ₂ | 4915 | 16- 3 ³ / ₄ | 4972 | 6- 8 ⁷ / ₈ | 2054 | 7- 2 ³ / ₈ | 2194 | 6- 8 ⁷ / ₈ | 2054 | |
| 60 to 64, 6K to 6R | 15- 0 | 4572 | 14- 5 ³ / ₄ | 4413 | 14- 7 ³ / ₄ | 4464 | 6- 0 ⁵ / ₈ | 2124 | 7- 4 ³ / ₈ | 2245 | 6- 10 ⁵ / ₈ | 2124 | |
| 65 to 69, 6T to 6Z | 16- 8 ¹ / ₂ | 5093 | 16- 2 ¹ / ₄ | 4934 | 16- 4 ¹ / ₄ | 4985 | 6- 0 ⁵ / ₈ | 2124 | 7- 4 ³ / ₈ | 2245 | 6- 10 ⁵ / ₈ | 2124 | |
| 70 to 74, 7K to 7R†† | 17- 1 ¹ / ₂ | 5219 | 16- 11 ¹ / ₂ | 5169 | 16- 10 | 5131 | 7- 11 ¹ / ₂ | 2426 | 9- 6 ¹ / ₄ | 2972 | 9- 1 ³ / ₈ | 2778 | |
| 70 to 74, 7K to 7R*** | 17- 1 ¹ / ₂ | 5219 | 16- 11 ¹ / ₂ | 5169 | 16- 10 | 5131 | 7- 11 ¹ / ₂ | 2426 | 9- 6 ¹ / ₄ | 2972 | 9- 3 ⁵ / ₈ | 2835 | |
| 75 to 79, 7T to 7Z | 19- 1 ¹ / ₂ | 5829 | 18- 11 ¹ / ₂ | 5779 | 18- 10 | 5740 | 7- 11 ¹ / ₂ | 2426 | 9- 6 ¹ / ₄ | 2972 | 9- 3 ⁵ / ₈ | 2835 | |
| 80 to 84, 8K to 8R | 17- 4 ¹ / ₂ | 5296 | 17- 1 | 5207 | 16- 10 ¹ / ₂ | 5143 | 8- 10 ³ / ₄ | 2711 | 9- 8 ¹ / ₈ | 3029 | 10- 0 ⁹ / ₁₆ | 3063 | |
| 85 to 89, 8T to 8Z | 19- 4 ¹ / ₂ | 5905 | 19- 1 | 5817 | 18- 10 ¹ / ₂ | 5753 | 8- 10 ³ / ₄ | 2711 | 9- 8 ¹ / ₈ | 3029 | 10- 0 ⁹ / ₁₆ | 3063 | |

See Note 7

*Assumes both cooler and condenser nozzles on same end of chiller.

†Compressor frame size 2.

**Compressor frame size 3.

††Compressor frame size 4.

***Compressor frame size 5 and E.

NOTES:

1. Service access should be provided per American Society of Heating, Refrigerating, and Air-Conditioning Engineers (ASHRAE) 15, latest edition, National Fire Protection Association (NFPA) 70, and local safety code.
2. Allow at least 3 ft (915 mm) overhead clearance for service rigging for frame 2-4 compressor. Overhead clearance for service rigging frame 5 and E compressor should be 5 ft (1524 mm).

3. Dimensions are approximate. Certified drawings available upon request.

4. Marine waterboxes may add 6 in. (152 mm) to the width of the machine. See certified drawings for details.

5. 'A' length dimensions shown are for standard 150 psig (1034 kPa) design and Victaulic connections. The 300 psig (2068 kPa) design and/or flanges will add length. See certified drawings.

6. Not all waterbox/pass combinations are available with unit-mounted VFD. Check selection program and Drawing Manager for availability.

7. 19XRV heights can vary depending on the configuration. Check 19XRV certified drawings for height information.

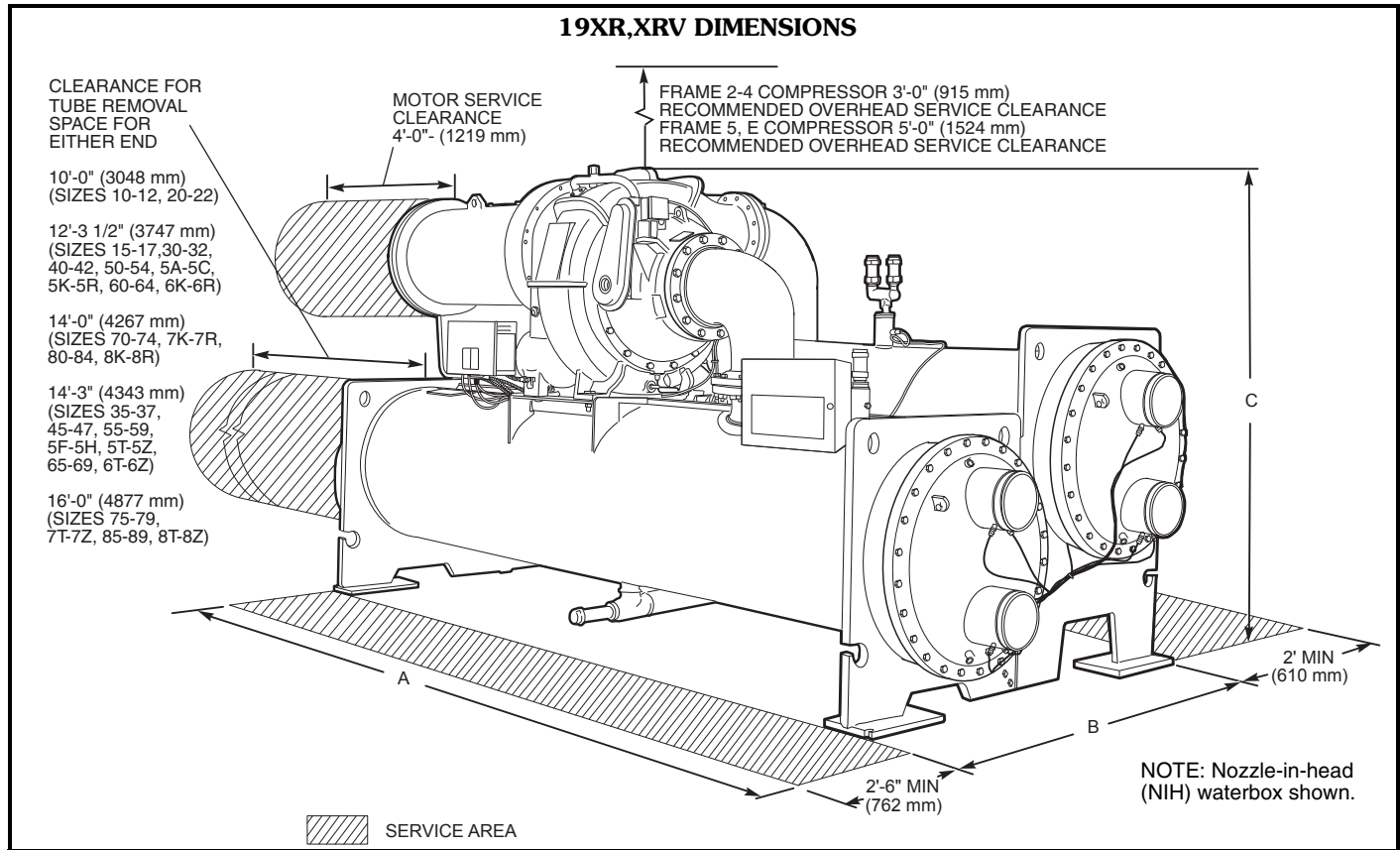

19XR,XRV DIMENSIONS — SINGLE-STAGE COMPRESSOR AND TWO-STAGE COMPRESSOR FRAME SIZE E (Marine Waterbox)

| HEAT EXCHANGER SIZE | A (Length, Marine Waterbox) | | | | 19XR B WIDTH | | 19XRV B WIDTH | | 19XR,XRV C HEIGHT |
|---------------------|-----------------------------|------|--------------|------|--------------|------|---------------|------|-------------------|
| | 2-Pass* | | 1 or 3-Pass† | | ft-in. | mm | ft-in. | mm | |
| | ft-in. | mm | ft-in. | mm | | | | | |
| 10 to 12 | NA | NA | NA | NA | NA | NA | NA | NA | See Note 6 |
| 15 to 17 | NA | NA | NA | NA | NA | NA | NA | NA | |
| 20 to 22 | 12- 5 1/2 | 3797 | 14- 1 1/4 | 4299 | 6- 1 1/16 | 1856 | 6- 1 1/16 | 1856 | |
| 30 to 32 | 14- 9 | 4496 | 16- 4 3/4 | 4997 | 6- 1 1/16 | 1856 | 6- 1 1/16 | 1856 | |
| 35 to 37 | 16- 5 1/2 | 5017 | 18- 1 1/4 | 5518 | 6- 1 1/16 | 1856 | 6- 1 1/16 | 1856 | |
| 40 to 42 | 15- 2 3/4 | 4642 | 16- 8 1/4 | 5086 | 6- 3 1/4 | 1911 | 6- 3 1/4 | 1911 | |
| 45 to 47 | 16- 11 1/4 | 5163 | 18- 4 3/4 | 5607 | 6- 3 1/4 | 1911 | 6- 3 1/4 | 1911 | |
| 50 to 54, 5K to 5R | 15- 3 1/2 | 4661 | 16- 8 1/2 | 5093 | 6- 8 7/8 | 2054 | 6- 8 7/8 | 2054 | |
| 5A to 5C | 15- 3 1/2 | 4661 | 16- 8 1/2 | 5093 | 6- 8 7/8 | 2054 | 6- 8 7/8 | 2054 | |
| 55 to 59, 5T to 5Z | 17- 0 | 5182 | 18- 5 | 5613 | 6- 8 7/8 | 2054 | 6- 8 7/8 | 2054 | |
| 5F to 5H | 17- 0 | 5182 | 18- 5 | 5613 | 6- 8 7/8 | 2054 | 6- 8 7/8 | 2054 | |
| 60 to 64, 6K to 6R | 15- 4 1/8 | 4677 | 16- 8 3/4 | 5099 | 6- 11 3/4 | 2127 | 6- 11 3/4 | 2127 | |
| 65 to 69, 6T to 6Z | 17- 0 5/8 | 5197 | 18- 5 1/4 | 5620 | 6- 11 3/4 | 2127 | 6- 11 3/4 | 2127 | |
| 70 to 74, 7K to 7R | 18- 3 5/8 | 5579 | 19- 9 3/4 | 6039 | 8- 8 1/8 | 2645 | 9- 6 3/8 | 2905 | |
| 75 to 79, 7T to 7Z | 20- 3 5/8 | 6188 | 21- 9 3/4 | 6649 | 8- 8 1/8 | 2645 | 9- 6 3/8 | 2905 | |
| 80 to 84, 8K to 8R | 18- 4 | 5583 | 19- 10 1/2 | 6058 | 9- 5 5/8 | 2886 | 10- 5 | 3175 | |
| 85 to 89, 8T to 8Z | 20- 4 | 6198 | 21- 10 1/2 | 6668 | 9- 5 5/8 | 2886 | 10- 5 | 3175 | |

*Assumes both cooler and condenser nozzles on same end of chiller.
†1 or 3-pass length applies if cooler is a 1 or 3-pass design.

NOTES:

- Service access should be provided per American Society of Heating, Refrigerating, and Air-Conditioning Engineers (ASHRAE) 15, latest edition, National Fire Protection Association (NFPA) 70, and local safety code.
- Allow at least 3 ft (915 mm) overhead clearance for service rigging for frame 2-4 compressor. Overhead clearance for service rigging frame 5 and frame E compressor should be 5 ft (1524 mm).
- Dimensions are approximate. Certified drawings available upon request.

- Marine waterboxes may add 6 in. (152 mm) to the width of the machine. See certified drawings for details.
- 'A' length dimensions shown are for standard 150 psig (1034 kPa) design and Victaulic connections. The 300 psig (2068 kPa) design and/or flanges will add length. See certified drawings.
- 19XR,XRV heights can vary depending on the configuration. Check 19XR,XRV certified drawings for height information.
- Not all waterbox/pass combinations are available with unit-mounted VFD (variable frequency drive). Check selection program for availability.

19XR DIMENSIONS — TWO-STAGE COMPRESSOR FRAME SIZES 6 AND 7 (Dished Head Waterbox)

| COOLER HEAT EXCHANGER SIZE | CONDENSER HEAT EXCHANGER SIZE | A (Length, Dished Head Waterbox) | | | | | | 19XR B WIDTH | | 19XR C HEIGHT |
|----------------------------|-------------------------------|-----------------------------------|------|-----------------------------------|------|-----------------------------------|------|-----------------------------------|------|---------------|
| | | 1-Pass | | 2-Pass | | 3-Pass | | ft-in. | mm | |
| | | ft-in. | mm | ft-in. | mm | ft-in. | mm | | | |
| A4* | A4* | 17- 8 | 5385 | 17- 6 ³ / ₄ | 5353 | 17- 6 ³ / ₄ | 5353 | 10- 3 ¹ / ₈ | 3127 | See Note 6 |
| A6* | A6* | 19- 8 | 5994 | 19- 6 ³ / ₄ | 5962 | 19- 6 ³ / ₄ | 5962 | 10- 3 ¹ / ₈ | 3127 | |
| A4* | B4* | 17- 8 | 5385 | 17- 7 ³ / ₈ | 5369 | 17- 7 ³ / ₈ | 5369 | 10- 8 ¹ / ₂ | 3264 | |
| A6* | B6* | 19- 8 | 5994 | 19- 7 ³ / ₈ | 5978 | 19- 7 ³ / ₈ | 5978 | 10- 8 ¹ / ₂ | 3264 | |
| B6* | C6* | 20- 0 | 6096 | 19-11 ¹ / ₈ | 6074 | 19- 9 | 6120 | 12- 0 ⁵ / ₈ | 3674 | |
| B8* | C8* | 22- 0 | 6096 | 21-11 ¹ / ₈ | 6684 | 21- 9 | 6629 | 12- 5 ¹ / ₂ | 3797 | |
| C6* | C6* | 20- 4 ¹ / ₄ | 6204 | 19-11 ¹ / ₈ | 6074 | 19-11 ³ / ₄ | 6090 | 12- 5 ¹ / ₂ | 3797 | |
| C6* | D6* | 20- 4 ¹ / ₄ | 6204 | 20- 0 | 6096 | 20- 0 ¹ / ₂ | 6109 | 13- 2 | 4013 | |

*Assumes both cooler and condenser nozzles on same end of chiller.
 †Consult factory for dimensions.

NOTES:

1. Service access should be provided per American Society of Heating, Refrigerating, and Air-Conditioning Engineers (ASHRAE) 15, latest edition, National Fire Protection Association (NFPA) 70, and local safety code.
2. Allow at least 5 ft (1524 mm) overhead clearance for service rigging.
3. Dimensions are approximate. Certified drawings available upon request.

4. 'A' length dimensions shown are for standard 150 psig (1034 kPa) design and Flanged connections.
5. Table contains heat exchanger dimensions for largest type shown.
6. 19XR heights can vary depending on the configuration. Check 19XR certified drawings for height information.

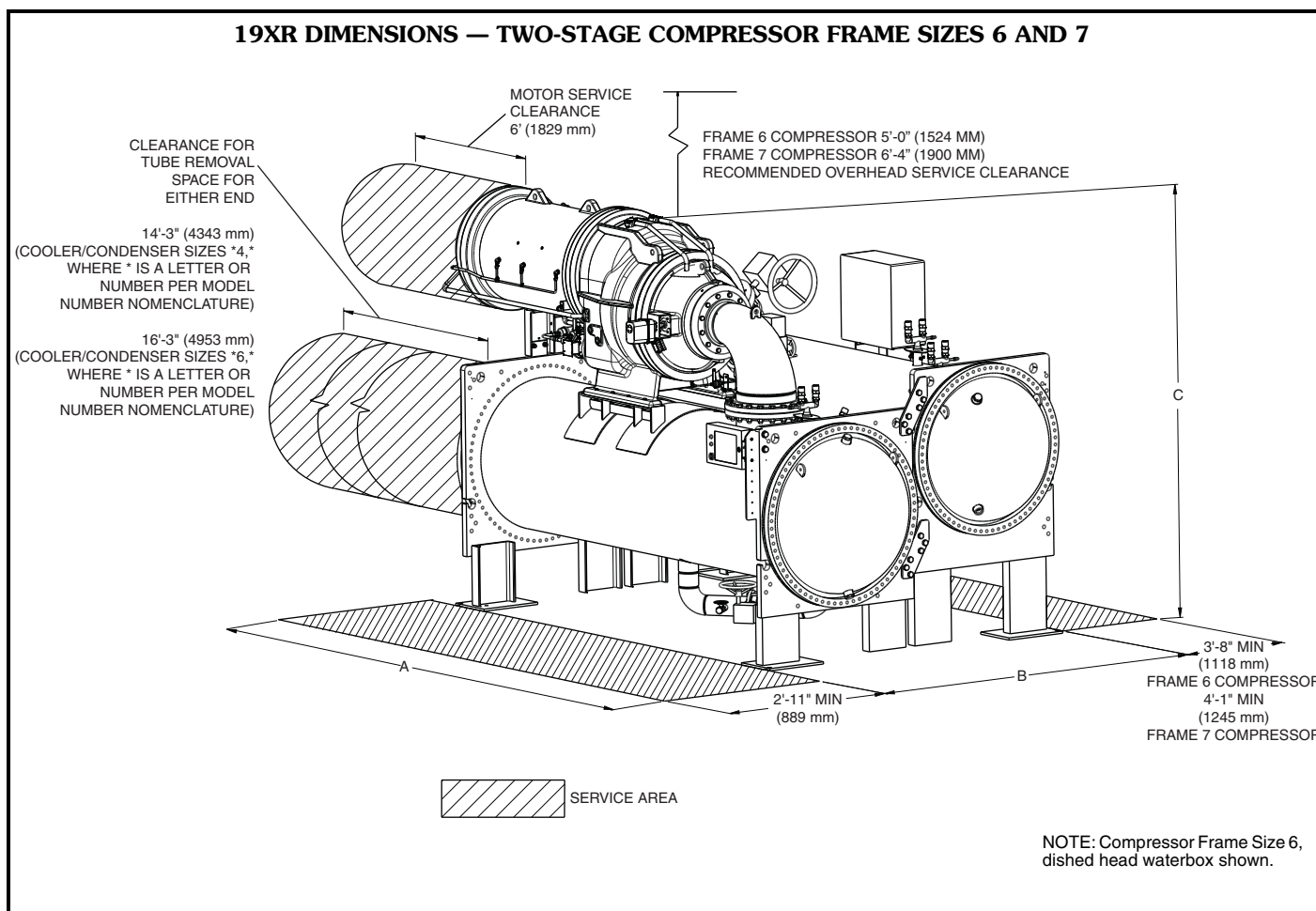

Dimensions (cont)



19XR DIMENSIONS — TWO-STAGE COMPRESSOR FRAME SIZES 6 AND 7 (150 psig Marine Waterbox)

| COOLER HEAT EXCHANGER SIZE | CONDENSER HEAT EXCHANGER SIZE | A (LENGTH, MARINE WATERBOX) | | | | | | 19XR B WIDTH | | 19XR C HEIGHT |
|----------------------------|-------------------------------|-----------------------------------|------|-----------------------------------|-------|-----------------------------------|-------|------------------------------------|------|---------------|
| | | 1-Pass | | 2-Pass | | 3-Pass | | ft-in. | mm | |
| | | ft-in. | mm | ft-in. | mm | ft-in. | mm | | | |
| A4* | A4* | 23- 1 ³ / ₄ | 7055 | 21- 8 ¹ / ₂ | 6617 | 20-11 | 6375 | 10- 6 ³ / ₈ | 3210 | See Note 6 |
| A6* | A6* | 25- 1 ³ / ₄ | 7665 | 23- 8 ¹ / ₂ | 7226 | 22-11 | 6985 | 10- 6 ³ / ₈ | 3210 | |
| A4* | B4* | 23- 1 ³ / ₄ | 7055 | 22- 1 ³ / ₄ | 6750 | 21- 1 ³ / ₄ | 6446 | 11- 0 ¹ / ₈ | 3356 | |
| A6* | B6* | 25- 1 ³ / ₄ | 7665 | 24- 1 ³ / ₄ | 7360 | 23- 1 ³ / ₄ | 7055 | 11- 0 ¹ / ₈ | 3356 | |
| B6* | C6* | 26- 6 ³ / ₄ | 8097 | 25- 2 ¹ / ₂ | 7680 | 24- 2 ³ / ₄ | 7385† | 12- 3 ⁷ / ₈ | 3756 | |
| B8* | C8* | 28- 6 ³ / ₄ | 8706 | 27- 2 ¹ / ₂ | 8293 | 26- 2 ³ / ₄ | 7994 | 12- 10 ³ / ₈ | 3921 | |
| C6* | C6* | 26- 6 ³ / ₄ | 8097 | 25- 4 ⁷ / ₈ | 7744 | 24- 2 ³ / ₄ | 8097 | 12- 3 ⁷ / ₈ | 3756 | |
| C6* | D6* | 26-11 | 8204 | 25- 7 ¹ / ₈ | 25705 | 24- 7 | 7493 | 13- 6 ⁵ / ₈ | 4131 | |

*Assumes both cooler and condenser nozzles on same end of chiller.

†Consult factory for dimensions.

NOTES:

1. Service access should be provided per American Society of Heating, Refrigerating, and Air-Conditioning Engineers (ASHRAE) 15, latest edition, National Fire Protection Association (NFPA) 70, and local safety code.
2. Allow at least 5 ft (1524 mm) overhead clearance for service rigging.

3. Dimensions are approximate. Certified drawings available upon request.

4. 'A' length dimensions shown are for standard 150 psig (1034 kPa) design and Flanged connections.

5. Table contains largest of all configurations of the type shown.

6. 19XR heights can vary depending on the configuration. Check 19XR certified drawings for height information.

19XR DIMENSIONS — TWO-STAGE COMPRESSOR FRAME SIZES 6 AND 7 (300 psig ASME Marine Waterbox)

| COOLER HEAT EXCHANGER SIZE | CONDENSER HEAT EXCHANGER SIZE | A (Length, Marine Waterbox) | | | | | | 19XR B WIDTH | | 19XR C HEIGHT |
|----------------------------|-------------------------------|-----------------------------------|------|-----------------------------------|------|-----------------------------------|------|-----------------------------------|------|---------------|
| | | 1-Pass | | 2-Pass | | 3-Pass | | ft-in. | mm | |
| | | ft-in. | mm | ft-in. | mm | ft-in. | mm | | | |
| A4* | A4* | 21- 5 ¹ / ₂ | 6541 | 20- 5 | 6223 | 19- 5 ¹ / ₂ | 5931 | 10- 8 ⁵ / ₈ | 3267 | See Note 6 |
| A6* | A6* | 23- 5 ¹ / ₂ | 7150 | 22- 5 | 6833 | 21- 5 ¹ / ₂ | 6541 | 10- 8 ⁵ / ₈ | 3267 | |
| A4* | B4* | 21- 5 ¹ / ₂ | 6541 | 20- 7 ¹ / ₂ | 6287 | 19- 5 ¹ / ₂ | 5931 | 11- 2 ³ / ₈ | 3413 | |
| A6* | B6* | 23- 5 ¹ / ₂ | 7150 | 22- 7 ¹ / ₂ | 6287 | 21- 5 ¹ / ₂ | 6541 | 11- 2 ⁷ / ₈ | 3426 | |
| B6* | C6* | 24- 5 ³ / ₄ | 7462 | 23- 1 ³ / ₄ | 7055 | 22- 1 ³ / ₄ | 6750 | 12- 6 ¹ / ₈ | 3813 | |
| C6* | C6* | 24- 5 ³ / ₄ | 7462 | 23- 2 ¹ / ₂ | 7068 | 22- 1 ³ / ₄ | 6750 | 13- 0 ⁷ / ₈ | 3884 | |
| B8* | C8* | 26- 5 ³ / ₄ | 8071 | 25- 1 ³ / ₄ | 7055 | 24- 1 ³ / ₄ | 7360 | 12- 6 ¹ / ₈ | 3813 | |
| C6* | D6* | 24- 7 ³ / ₄ | 7512 | 23- 3 ¹ / ₂ | 7099 | 22- 3 ³ / ₄ | 6801 | 13- 9 ¹ / ₂ | 4204 | |

*Assumes both cooler and condenser nozzles on same end of chiller.

†Consult factory for dimensions.

NOTES:

1. Service access should be provided per American Society of Heating, Refrigerating, and Air-Conditioning Engineers (ASHRAE) 15, latest edition, National Fire Protection Association (NFPA) 70, and local safety code.
2. Allow at least 5 ft (1524 mm) overhead clearance for service rigging.

3. Dimensions are approximate. Certified drawings available upon request.

4. 'A' length dimensions shown are for standard 150 psig (1034 kPa) design and Flanged connections.

5. Table contains largest of all configurations of the type shown.

6. 19XR heights can vary depending on the configuration. Check 19XR certified drawings for height information.

NOZZLE SIZE

| HEAT EXCHANGER FRAME SIZE | NOZZLE SIZE (in.) (Nominal Pipe Size) | | | | | |
|---------------------------|---------------------------------------|--------|--------|-----------|--------|--------|
| | Cooler | | | Condenser | | |
| | 1-Pass | 2-Pass | 3-Pass | 1-Pass | 2-Pass | 3-Pass |
| 1 | 8 | 6 | 6 | 8 | 6 | 6 |
| 2 | 10 | 8 | 6 | 10 | 8 | 6 |
| 3 | 10 | 8 | 6 | 10 | 8 | 6 |
| 4 | 10 | 8 | 6 | 10 | 8 | 6 |
| 5 | 10 | 8 | 6 | 10 | 10 | 8 |
| 6 | 10 | 10 | 8 | 10 | 10 | 8 |
| 7 | 14 | 12 | 10 | 14 | 12 | 12 |
| 8 | 14 | 14 | 12 | 14 | 18 | 12 |
| A | 20 | 16 | 12 | 20 | 16 | 14 |
| B | 20 | 18 | 14 | 20 | 18 | 14 |
| C | 20 | 18 | 14 | 24 | 20 | 16 |
| D | — | — | — | 24 | 20 | 16 |

Selection procedure



Compressor motor controllers

Compressor motors, as well as controls and accessories, require the use of starting equipment systems specifically designed for 19XR or 19XRV chillers. Consult your local Carrier representative regarding design information for the selection of starters.

Capacitors/power factors

Power factor considerations may indicate use of capacitors. Properly sized capacitors improve power factors, especially at part load. The 19XR, XRV Computer Selection program can select the proper capacitor size required for the application.

Electrical data

AUXILIARY RATINGS (Oil Pump) (3 Phase, 50/60 Hz)

| ITEM | AVERAGE kW | MIN/MAX MOTOR VOLTAGE/FREQUENCY V-Ph-Hz | FLA | LRA | SEALED kva | INRUSH kva |
|----------|------------|---|------|------|------------|------------|
| OIL PUMP | 1.35 | 200/240-3-60 | 5.15 | 24.5 | 1.96 | 9.34 |
| | 1.30 | 380/460-3-60 | 2.55 | 13.1 | 1.86 | 9.53 |
| | 1.37 | 507/619-3-60 | 2.54 | 25.0 | 2.48 | 24.38 |
| | 1.50 | 220/240-3-50 | 5.74 | 28.0 | 2.29 | 11.15 |
| | 1.50 | 346/440-3-50 | 3.07 | 12.2 | 2.09 | 8.30 |

LEGEND

FLA — Full Load Amps
LRA — Locked Rotor Amps

NOTE: FLA = Sealed kva • 1000/√3 • volts
LRA = Inrush kva • 1000/√3 • volts

AUXILIARY RATINGS (Controls, Oil Sump Heater)

| ITEM | POWER SUPPLY | SEALED kva | AVERAGE WATTS |
|----------------------------|---|------------|---------------------------------|
| CONTROLS | 24-vac | 0.2 | 200 |
| OIL SUMP HEATER V-Ph-Hz | 115 V or 230 V, Single Phase, 50 or 60 Hz | — | 1500 (Frame 2 Compressor) |
| | | | 1800 (Frame 3,4 Compressor) |
| | | | 2200 (Frame 5, E Compressor) |
| | 380 V, 50 or 60 Hz; 460 V, 50 or 60 Hz | — | 1800 (Frame 4 SRD Only) |
| | | | 3000 (Frame 6 Compressor) |
| | | | 3500 (Frame 7 Compressor) |

LEGEND

SRD — Split Ring Diffuser

NOTES:

- Oil sump heater only operates when the compressor is off.
- Power to oil heater/controls must be on circuits that can provide continuous service when the compressor is disconnected.

LOW VOLTAGE POWER (Control Panel) (3 Phase, 50/60 Hz)

| FRAME SIZE | MCA | MOCP |
|------------|--------|------|
| XR6 380V | 16 | 20 |
| XR6 460V | 13.2 | 15 |
| XR7 380V | 17.7 | 20 |
| XR7 460V | 1.14.6 | 20 |

Microprocessor controls

Microprocessor controls provide the safety, interlock, capacity control, and indications necessary to operate the chiller in a safe and efficient manner.

Control system

The microprocessor control on each Carrier centrifugal system is factory mounted, wired, and tested to ensure machine protection and efficient capacity control. In addition, the program logic ensures proper starting, stopping, and recycling of the chiller and provides a communication link to the Carrier Comfort Network® (CCN) system.

Features

Control system

- Component test and diagnostic check
- Programmable recycle allows chiller to recycle at optimum loads for decreased operating costs
- Menu-driven keypad interface for status display, set point control, and system configuration
- CCN compatible
- Primary and secondary status messages
- Individual start/stop schedules for local and CCN operation modes
- Recall of up to 25 alarm/alert messages with diagnostic help
- Two-chiller lead/lag with third chiller standby is standard
- Optional soft stop unloading closes guide vanes to unload the motor to the configured amperage level prior to stopping
- Languages pre-programmed at factory for English and Chinese
- An ILT (international language translator) is available for conversion of extended ASCII characters

Safety cutouts

- Bearing oil high temperature*
- Motor high temperature*†
- Refrigerant (condenser) high pressure*†
- Refrigerant (cooler) low temperature*†
- Lube oil low pressure
- Compressor (refrigerant) discharge temperature*
- Under voltage**
- Over voltage**
- Oil pump motor overload
- Motor overload†
- Motor acceleration time
- Intermittent power loss

- Compressor starter faults
- Compressor surge protection*
- Low level ground fault
 - Low voltage — phase to phase and phase to ground
 - Medium voltage — phase to phase and phase to ground
- Cooler freeze protection

Capacity control

- Leaving chilled water control
- Entering chilled water control
- Ice build control
- Soft loading control by temperature or load ramping
- Guide vane actuator module
- Hot gas bypass valve
- Power (demand) limiter
- Auto. chilled water reset
- Variable chiller optimization (VDO) (available on compressor frame sizes 4 and 5 with diffuser control enabled)
- Compressor surge prevention control

Interlocks

- Manual/automatic remote start
- Starting/stopping sequence
 - Pre-lube/post-lube
 - Pre-flow/post-flow
- Compressor starter run interlock
- Pre-start check of safeties and alerts
- Low chilled water (load) recycle
- Monitor/number compressor starts and run hours
- Manual reset of safeties

Indications

- Chiller operating status message
- Power-on
- Pre-start diagnostic check
- Compressor motor amps
- Pre-alarm alert††
- Alarm
- Contact for remote alarm
- Safety shutdown messages
- Elapsed time (hours of operation)
- Chiller input kW

*These can be configured by user to provide alert indication at user-defined limit.

†Override protection: Causes compressor to first unload and then, if necessary, shut down.

**Will not require manual reset or cause an alarm if auto-restart after power failure is enabled.

††By display code only.

Typical piping and wiring

19XR CHILLER WITH FREE-STANDING STARTER OR VFD

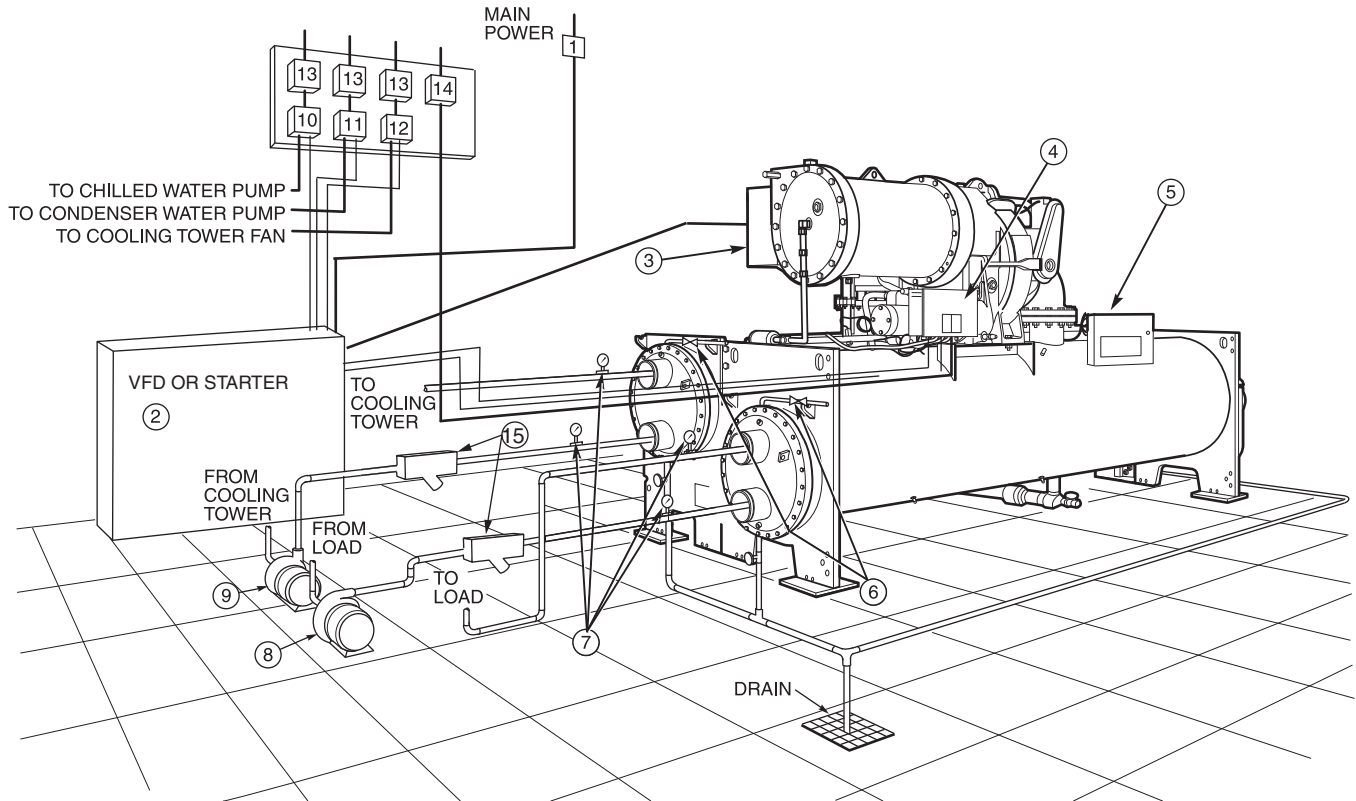

LEGEND

- 1 — Disconnect
- 2 — Free-standing Compressor Motor Starter or VFD
- 3 — Compressor Motor Terminal Box
- 4 — Power Panel
- 5 — Control Panel
- 6 — Vents
- 7 — Pressure Gages
- 8 — Chilled Water Pump
- 9 — Condenser Water Pump
- 10 — Chilled Water Pump Starter
- 11 — Condensing Water Pump Starter
- 12 — Cooling Tower Fan Starter (Low Fan, High Fan)
- 13 — Disconnect
- 14 — Oil Pump Disconnect (See Note 4)
- 15 — Strainers

- Piping
- Control Wiring
- Power Wiring

NOTES:

1. Wiring and piping shown are for general point-of-connection only and are not intended to show details for a specific installation. Certified field wiring and dimensional diagrams are available on request.
2. All wiring must comply with applicable codes.
3. Wiring not shown for optional devices such as:
 - Remote Start/Stop
 - Remote Alarms
 - Optional Safety Device
 - 4 to 20 mA Resets
 - Optional Remote Sensors
4. Oil pump disconnect may be located within the enclosure of Item 2 — Free-standing Compressor Motor Starter.
5. **IMPORTANT:** Carrier suggests that a structural engineer be consulted if transmission of vibrations from mechanical equipment is of concern.
6. Isolation valves are recommended on the cooler and condenser piping to each chiller for service.
7. Operating environment — Chiller should be installed in an indoor environment where the ambient temperature is 40 to 104 F (4 to 40 C) with a relative humidity (non-condensing) of 95% or less. To ensure that electrical components operate properly, do not locate the chiller in an area exposed to dust, dirt, corrosive fumes, or excessive heat and humidity.

Typical piping and wiring (cont)

19XR CHILLER WITH OPTIONAL UNIT-MOUNTED STARTER OR VFD

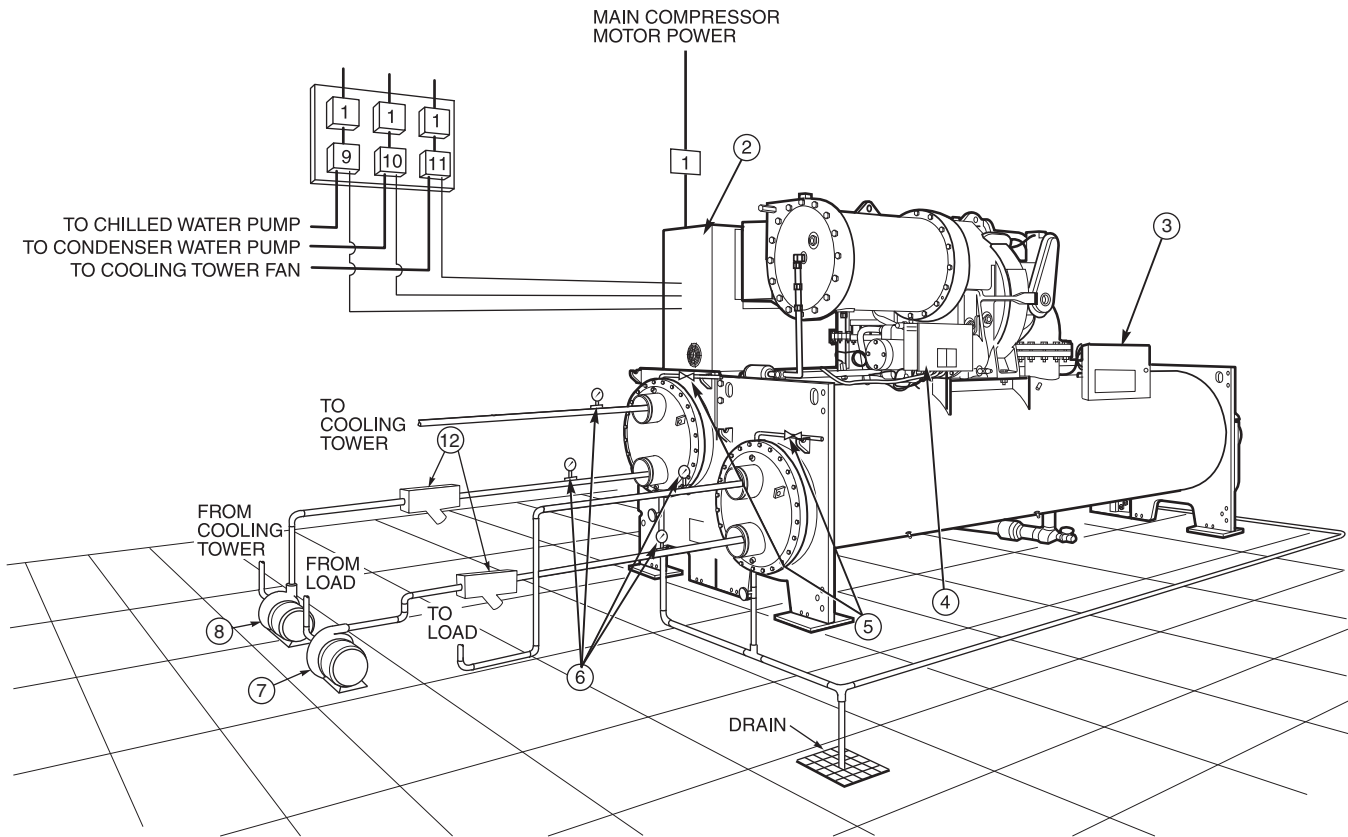

LEGEND

- 1 — Disconnect
 - 2 — Unit-Mounted Starter or VFD
 - 3 — Control Panel
 - 4 — Power Panel
 - 5 — Vents
 - 6 — Pressure Gages
 - 7 — Chilled Water Pump
 - 8 — Condenser Water Pump
 - 9 — Chilled Water Pump Starter
 - 10 — Condensing Water Pump Starter
 - 11 — Cooling Tower Fan Starter (Low Fan, High Fan)
 - 12 — Strainers
- Piping
 Control Wiring
 Power Wiring

NOTES:

1. Wiring and piping shown are for general point-of-connection only and are not intended to show details for a specific installation. Certified field wiring and dimensional diagrams are available on request.
2. All wiring must comply with applicable codes.
3. Wiring not shown for optional devices such as:
 - Remote Start/Stop
 - Remote Alarms
 - Optional Safety Device
 - 4 to 20 mA Resets
 - Optional Remote Sensors
4. **IMPORTANT:** Carrier suggests that a structural engineer be consulted if transmission of vibrations from mechanical equipment is of concern.
5. Isolation valves are recommended on the cooler and condenser piping to each chiller for service.
6. Operating environment — Chiller should be installed in an indoor environment where the ambient temperature is 40 to 104 F (4 to 40 C) with a relative humidity (non-condensing) of 95% or less. To ensure that electrical components operate properly, do not locate the chiller in an area exposed to dust, dirt, corrosive fumes, or excessive heat and humidity.

19XR,XRV SINGLE-STAGE COMPRESSOR MACHINE FOOTPRINT

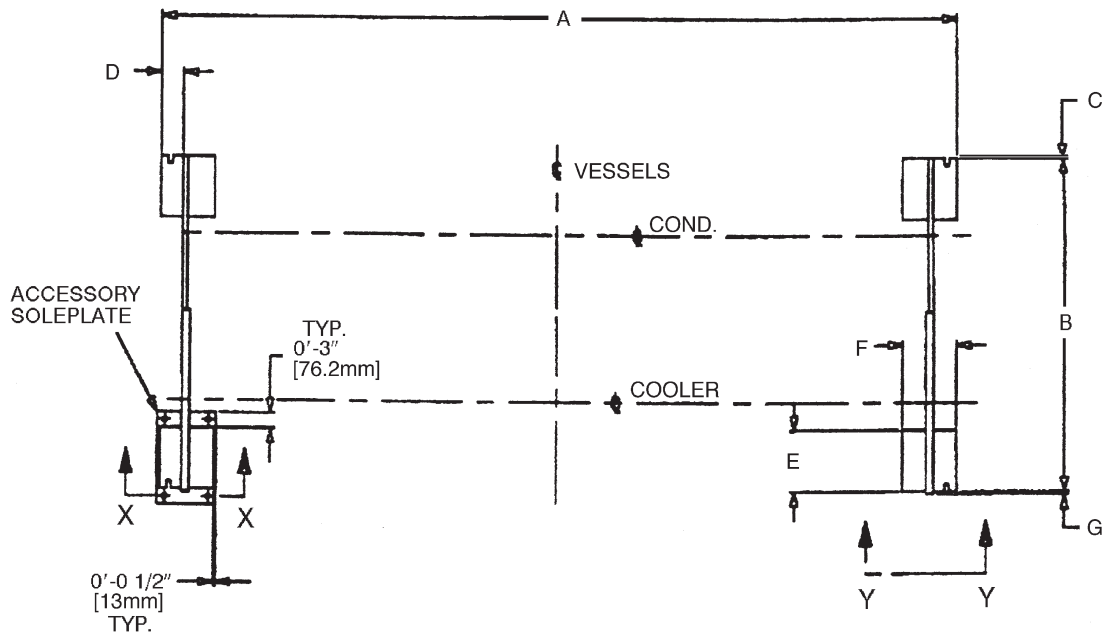

| 19XR,XRV HEAT EXCHANGER SIZE | DIMENSIONS | | | | | | | | | | | | | |
|------------------------------------|-----------------------------------|------|----------------------------------|------|-----------------------------------|----|-----------------------------------|-----|---------------------------------|-----|--------|-----|----------------------------------|----|
| | A | | B | | C | | D | | E | | F | | G | |
| | ft-in. | mm | ft-in. | mm | ft-in. | mm | ft-in. | mm | ft-in. | mm | ft-in. | mm | ft-in. | mm |
| 10-12 | 10- 7 ¹ / ₄ | 3232 | 4-10 ¹ / ₄ | 1480 | 0-1 | 25 | 0-3 ⁵ / ₈ | 92 | 1-3 ¹ / ₄ | 382 | 0-9 | 229 | 0-1 ¹ / ₂ | 13 |
| 15-17 | 12-10 ³ / ₄ | 3931 | 4-10 ¹ / ₄ | 1480 | 0-1 | 25 | 0-3 ⁵ / ₈ | 92 | 1-3 ¹ / ₄ | 382 | 0-9 | 229 | 0-1 ¹ / ₂ | 13 |
| 20-22 | 10- 7 ¹ / ₄ | 3232 | 5- 4 ¹ / ₄ | 1632 | 0-1 | 25 | 0-3 ⁵ / ₈ | 92 | 1-3 ¹ / ₄ | 382 | 0-9 | 229 | 0-1 ¹ / ₂ | 13 |
| 30-32 | 12-10 ³ / ₄ | 3931 | 5- 4 ¹ / ₄ | 1632 | 0 | 0 | 0-3 ⁵ / ₈ | 92 | 1-3 ¹ / ₄ | 382 | 0-9 | 229 | 0-1 ¹ / ₂ | 13 |
| 35-37 | 14- 7 ¹ / ₄ | 4451 | 5- 4 ¹ / ₄ | 1632 | 0 | 0 | 0-3 ⁵ / ₈ | 92 | 1-3 ¹ / ₄ | 382 | 0-9 | 229 | 0-1 ¹ / ₂ | 13 |
| 40-42 | 12-10 ³ / ₄ | 3931 | 6- 0 | 1829 | 0-1 ¹ / ₂ | 38 | 0-3 ⁵ / ₈ | 92 | 1-3 ¹ / ₄ | 382 | 0-9 | 229 | 0-1 ¹ / ₂ | 13 |
| 45-47 | 14- 7 ¹ / ₄ | 4451 | 6- 0 | 1829 | 0-1 ¹ / ₂ | 38 | 0-3 ⁵ / ₈ | 92 | 1-3 ¹ / ₄ | 382 | 0-9 | 229 | 0-1 ¹ / ₂ | 13 |
| 50-54, 5A-5C, 5K-5R | 12-10 ³ / ₄ | 3931 | 6- 5 ¹ / ₂ | 1968 | 0- 1 ¹ / ₂ | 13 | 0-3 ⁵ / ₈ | 92 | 1-3 ¹ / ₄ | 382 | 0-9 | 229 | 0-1 ¹ / ₂ | 13 |
| 55-59, 5F-5H, 5T-5Z | 14- 7 ¹ / ₄ | 4451 | 6- 5 ¹ / ₂ | 1968 | 0- 1 ¹ / ₂ | 13 | 0-3 ⁵ / ₈ | 92 | 1-3 ¹ / ₄ | 382 | 0-9 | 229 | 0-1 ¹ / ₂ | 13 |
| 60-64, 6K-6R | 12-10 ³ / ₄ | 3931 | 6- 9 ¹ / ₂ | 2070 | 0- 1 ¹ / ₂ | 13 | 0-3 ⁵ / ₈ | 92 | 1-3 ¹ / ₄ | 382 | 0-9 | 229 | 0-1 ¹ / ₂ | 13 |
| 65-69, 6T-6Z | 14- 7 ¹ / ₄ | 4451 | 6- 9 ¹ / ₂ | 2070 | 0- 1 ¹ / ₂ | 13 | 0-3 ⁵ / ₈ | 92 | 1-3 ¹ / ₄ | 382 | 0-9 | 229 | 0-1 ¹ / ₂ | 13 |
| 70-74, 7K-7R | 15- 1 ⁷ / ₈ | 4620 | 7-10 ¹ / ₂ | 2400 | 0- 1 ¹ / ₄ | 6 | 0-6 ¹⁵ / ₁₆ | 176 | 1-10 | 559 | 1-4 | 406 | 0-3 ¹ / ₄ | 19 |
| 75-79, 7T-7Z | 17- 1 ⁷ / ₈ | 5229 | 7-10 ¹ / ₂ | 2400 | 0- 1 ¹ / ₄ | 6 | 0-6 ¹⁵ / ₁₆ | 176 | 1-10 | 559 | 1-4 | 406 | 0-3 ¹ / ₄ | 19 |
| 80-84, 8K-8R | 15- 1 ⁷ / ₈ | 4620 | 8- 9 ³ / ₄ | 2686 | 0-1 ¹⁵ / ₁₆ | 24 | 0-6 ¹⁵ / ₁₆ | 176 | 1-10 | 559 | 1-4 | 406 | 0-1 ¹ / ₁₆ | 2 |
| 85-89, 8T-8Z | 17- 1 ⁷ / ₈ | 5229 | 8- 9 ³ / ₄ | 2686 | 0-1 ¹⁵ / ₁₆ | 24 | 0-6 ¹⁵ / ₁₆ | 176 | 1-10 | 559 | 1-4 | 406 | 0-1 ¹ / ₁₆ | 2 |

NOTES:

1. X-X dimension refers to accessory soleplate. See page 61.
2. Y-Y dimension refers to standard support plate. See page 61.

Application data (cont)

19XR TWO-STAGE COMPRESSORS FRAME SIZES 6 AND 7 MACHINE FOOTPRINT

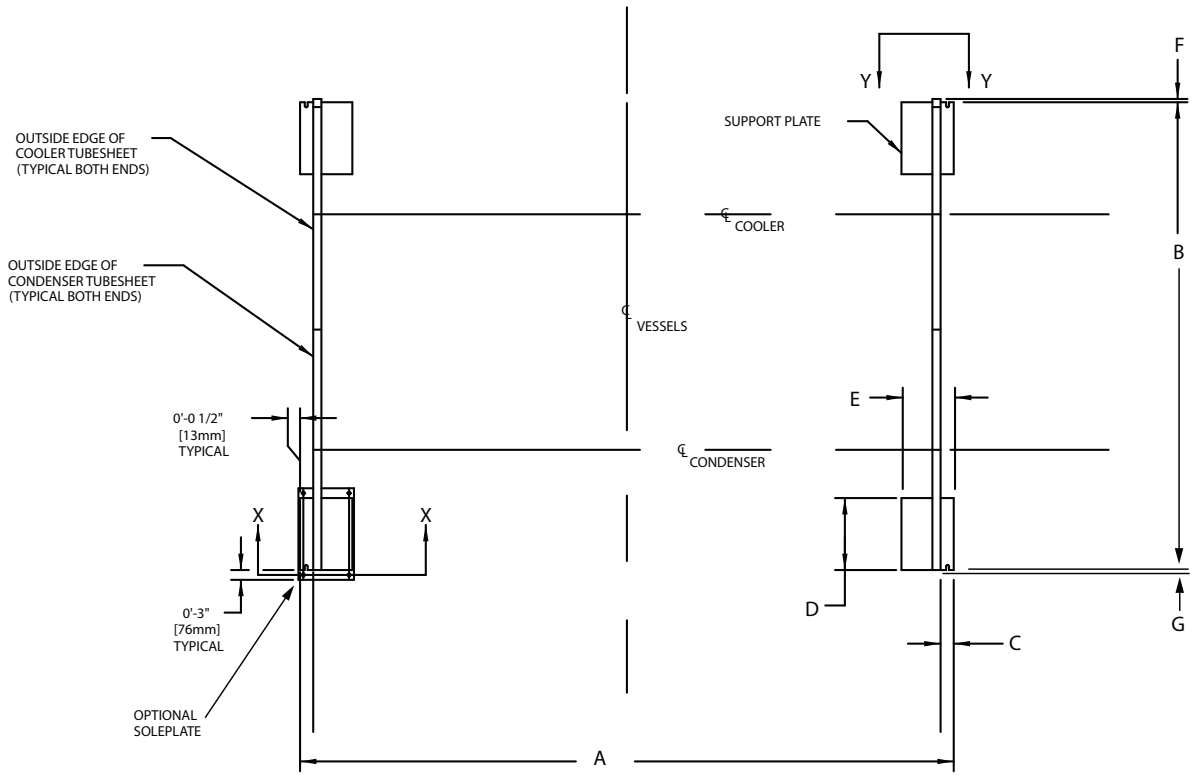

| 19XR HEAT EXCHANGER SIZE | | DIMENSIONS | | | | | | | | | | | | | |
|--------------------------------|-----------|-----------------------------------|------|-----------------------------------|------|----------------------------------|-----|--------|-----|--------|-----|--------|----|--------|----|
| | | A | | B | | C | | D | | E | | F | | G | |
| | | ft-in. | mm | ft-in. | mm | ft-in. | mm | ft-in. | mm | ft-in. | mm | ft-in. | mm | ft-in. | mm |
| COOLER | CONDENSER | | | | | | | | | | | | | | |
| A4 | A4 | 14- 8 ⁷ / ₈ | 4492 | 10- 0 ¹ / ₈ | 3051 | 0-4 ⁷ / ₁₆ | 113 | 1-10 | 559 | 1-4 | 406 | — | — | — | — |
| | B4 | 14- 8 ⁷ / ₈ | 4492 | 10- 5 ³ / ₈ | 3177 | 0-4 ⁷ / ₁₆ | 113 | 1-10 | 559 | 1-4 | 406 | — | — | — | — |
| A6 | A6 | 16- 8 ⁷ / ₈ | 5102 | 10- 0 ¹ / ₈ | 3051 | 0-4 ⁷ / ₁₆ | 113 | 1-10 | 559 | 1-4 | 406 | — | — | — | — |
| | B6 | 16- 8 ⁷ / ₈ | 5102 | 10- 5 ³ / ₈ | 3177 | 0-4 ⁷ / ₁₆ | 113 | 1-10 | 559 | 1-4 | 406 | — | — | — | — |
| B6 | C6 | 16 -8 | 5080 | 11-11 | 3632 | 0-4 | 102 | 1-10 | 559 | 1-4 | 406 | — | — | 0-1 | 25 |
| B8 | C8 | 18-8 | 5690 | 11-11 | 3632 | 0-4 | 102 | 1-10 | 559 | 1-4 | 406 | — | — | 0-1 | 25 |
| C6 | C6 | 16 -8 | 5080 | 12- 4 ¹ / ₂ | 3662 | 0-4 | 102 | 1-10 | 559 | 1-4 | 406 | — | — | 0-1 | 25 |
| | D6 | 16 -8 | 5080 | 13- 2 | 4013 | 0-4 | 102 | 1-10 | 559 | 1-4 | 406 | — | — | — | — |

NOTES:

1. X-X dimension refers to accessory soleplate. See page 61.
2. Y-Y dimension refers to standard support plate. See page 61.

19XR, XRV ISOLATION WITH ACCESSORY SOLEPLATE PACKAGE

TYPICAL ISOLATION

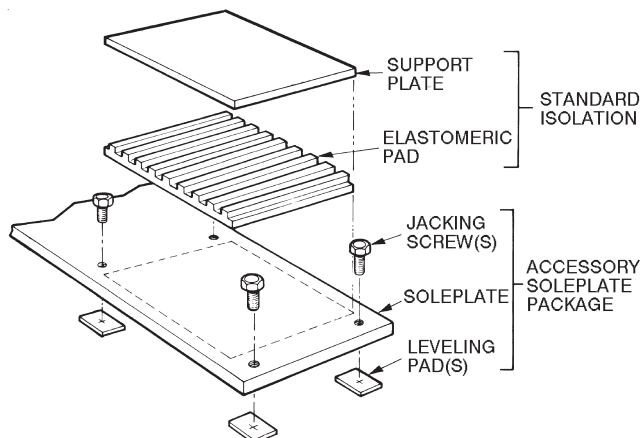

STANDARD ISOLATION

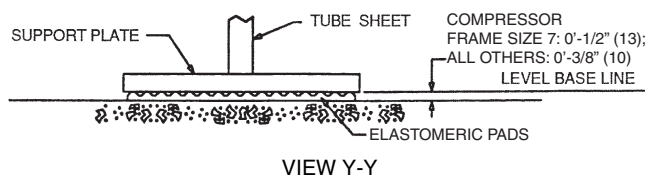

ISOLATION WITH STANDARD PACKAGE ONLY

NOTE: Isolation package includes 4 elastomeric pads.

ACCESSORY SOLEPLATE DETAIL

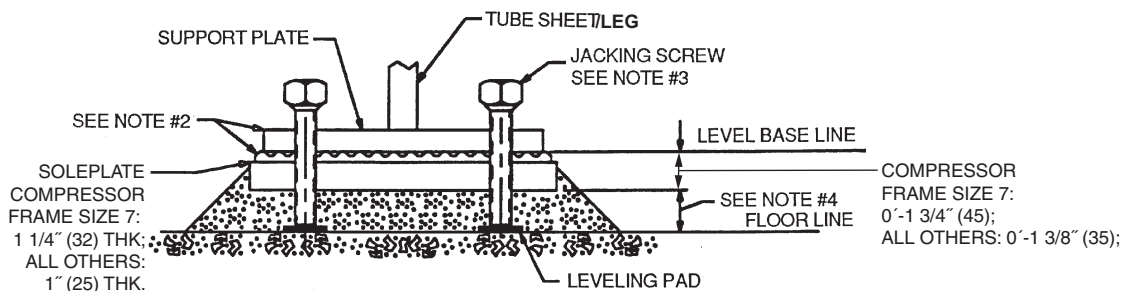

VIEW X-X

NOTES:

1. Dimensions in () are in millimeters.
2. Accessory (Carrier-supplied, field-installed) soleplate package includes 4 soleplates, 16 jacking screws and leveling pads. Isolation package is also required.
3. Jacking screws to be removed after grout has set.
4. Thickness of grout will vary, depending on the amount necessary to level chiller. Use only pre-mixed non-shrinking grout, Ceilcote 748 OR Embeco 636 Plus Grout, 0'-1 1/2" (38.1) to 0'-2 1/4" (57) thick.

19XR, XRV NOZZLE ARRANGEMENTS NOZZLE-IN-HEAD WATERBOXES

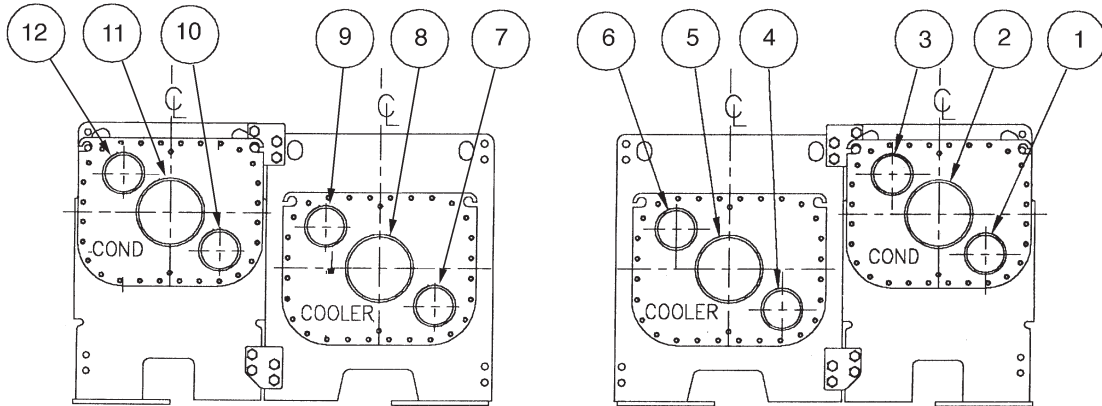

DRIVE END

COMPRESSOR END

FRAMES 1, 2, AND 3

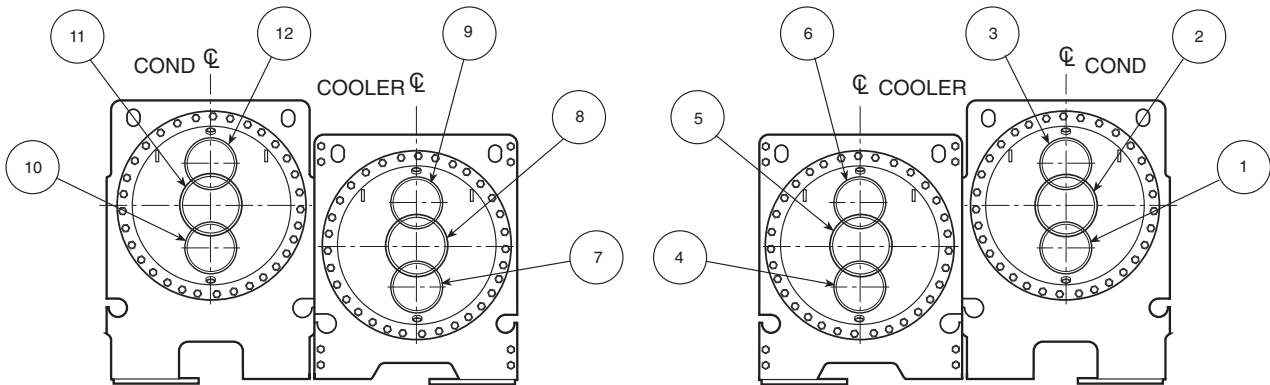

DRIVE END

COMPRESSOR END

FRAMES 4, 5, AND 6

19XR, XRV NOZZLE ARRANGEMENTS (cont)

NOZZLE-IN-HEAD WATERBOXES (cont)

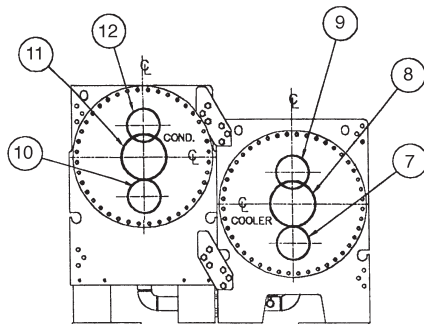

DRIVE END

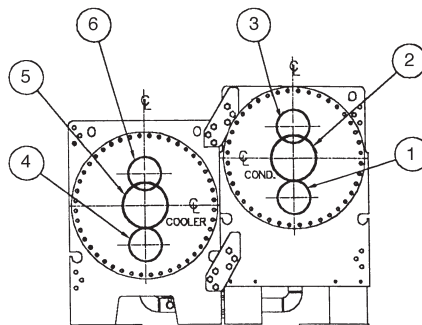

COMPRESSOR END

FRAMES 7 AND 8

NOZZLE ARRANGEMENT CODES FOR 19XR NOZZLE-IN-HEAD WATERBOXES FRAMES 1-8

| PASS | COOLER WATERBOXES | | |
|------|-------------------|-----|-------------------|
| | In | Out | Arrangement Code* |
| 1 | 8 | 5 | A |
| | 5 | 8 | B |
| 2 | 7 | 9 | C |
| | 4 | 6 | D |
| 3 | 7 | 6 | E |
| | 4 | 9 | F |

| PASS | CONDENSER WATERBOXES | | |
|------|----------------------|-----|-------------------|
| | In | Out | Arrangement Code* |
| 1 | 11 | 2 | P |
| | 2 | 11 | Q |
| 2 | 10 | 12 | R |
| | 1 | 3 | S |
| 3 | 10 | 3 | T |
| | 1 | 12 | U |

*Refer to certified drawings.

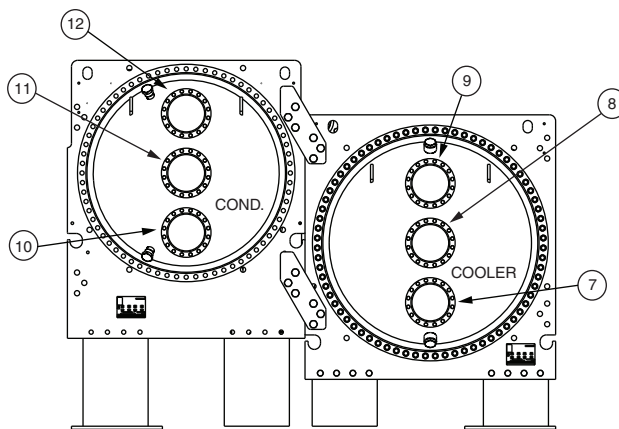

MOTOR END

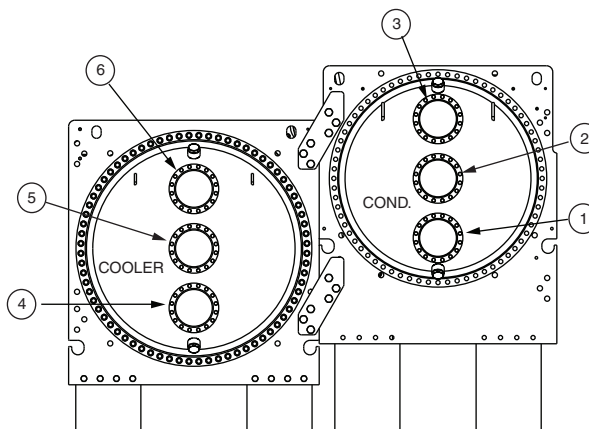

COMPRESSOR END

19XR TWO-STAGE COMPRESSORS FRAME SIZES 6 AND 7 (HEAT EXCHANGER FRAMES A, B, C, and D)

NOZZLE ARRANGEMENT CODES FOR 19XR TWO-STAGE COMPRESSORS FRAME SIZES 6 AND 7

| PASS | COOLER WATERBOXES | | |
|------|-------------------|-----|-------------------|
| | In | Out | Arrangement Code* |
| 1† | 8 | 5 | A |
| | 5 | 8 | B |
| 2 | 7 | 9 | C |
| | 4 | 6 | D |
| 3† | 7 | 6 | E |
| | 4 | 9 | F |

| PASS | CONDENSER WATERBOXES | | |
|------|----------------------|-----|-------------------|
| | In | Out | Arrangement Code* |
| 1† | 11 | 2 | P |
| | 2 | 11 | Q |
| 2 | 10 | 12 | R |
| | 1 | 3 | S |
| 3† | 10 | 3 | T |
| | 1 | 12 | U |

*Refer to certified drawings.

†One and 3 pass arrangements are available via special order only.

19XR,XRV NOZZLE ARRANGEMENTS (cont)

MARINE WATERBOXES

NOTE :
COOLER 3-PASS NOZZLE @ 45°
(NOT SHOWN) SIMILIAR TO
CONDENSER 2-PASS

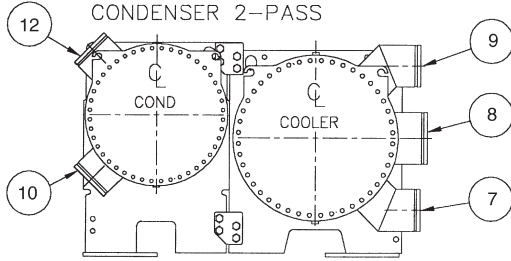

DRIVE END

NOTE :
COOLER 3-PASS NOZZLE @ 45°
(NOT SHOWN) SIMILIAR TO
CONDENSER 2-PASS

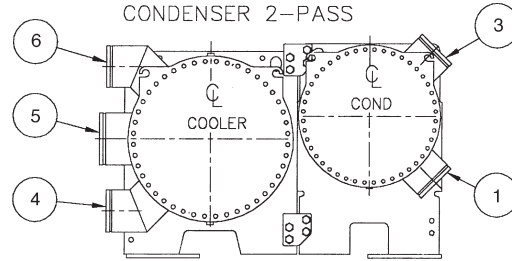

COMPRESSOR END

FRAMES 2 AND 3†

†There is no Frame 1 marine waterbox.

NOZZLE ARRANGEMENT CODES

| PASS | COOLER WATERBOXES | | | CONDENSER WATERBOXES | | |
|------|-------------------|-----|------------------|----------------------|-----|------------------|
| | In | Out | Arrangement Code | In | Out | Arrangement Code |
| 1 | 8 | 5 | A | — | — | — |
| | 5 | 8 | B | — | — | — |
| 2 | 7 | 9 | C | 10 | 12 | R |
| | 4 | 6 | D | 1 | 3 | S |
| 3 | 7 | 6 | E | — | — | — |
| | 4 | 9 | F | — | — | — |

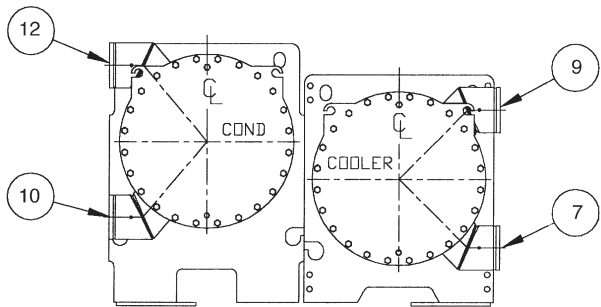

DRIVE END

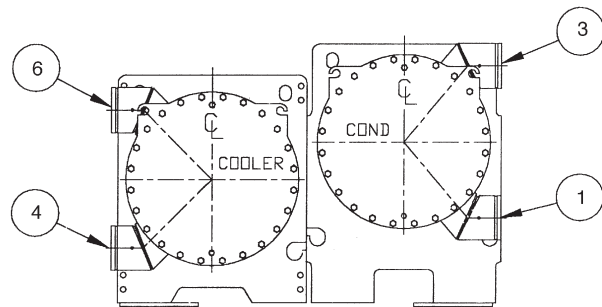

COMPRESSOR END

FRAMES 4, 5, AND 6

NOZZLE ARRANGEMENT CODES

| PASS | COOLER WATERBOXES | | | CONDENSER WATERBOXES | | |
|------|-------------------|-----|------------------|----------------------|-----|------------------|
| | In | Out | Arrangement Code | In | Out | Arrangement Code |
| 1 | 9 | 6 | A | — | — | — |
| | 6 | 9 | B | — | — | — |
| 2 | 7 | 9 | C | 10 | 12 | R |
| | 4 | 6 | D | 1 | 3 | S |
| 3 | 7 | 6 | E | — | — | — |
| | 4 | 9 | F | — | — | — |

19XR, XRV NOZZLE ARRANGEMENTS (cont)
MARINE WATERBOXES (cont)

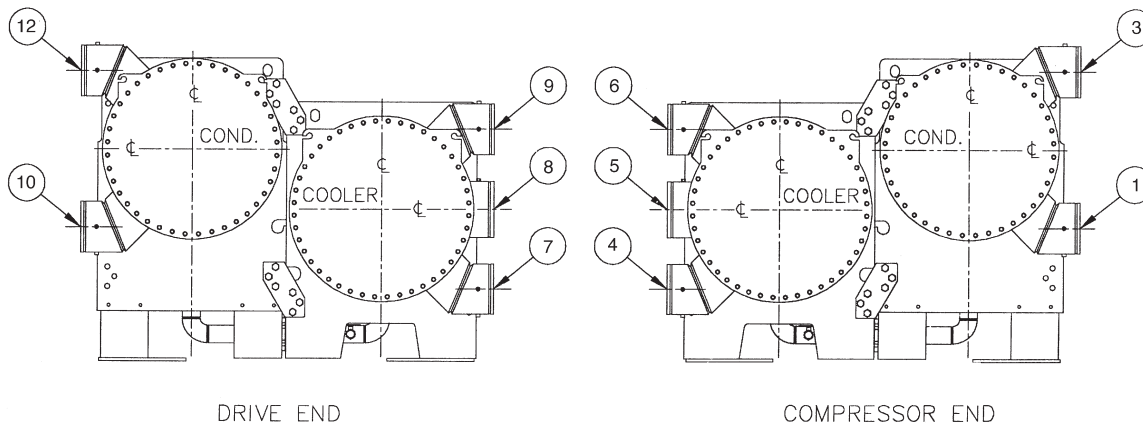

FRAMES 7 AND 8
NOZZLE ARRANGEMENT CODES

| PASS | COOLER WATERBOXES | | | CONDENSER WATERBOXES | | |
|------|-------------------|-----|------------------|----------------------|-----|------------------|
| | In | Out | Arrangement Code | In | Out | Arrangement Code |
| 1 | 8 | 5 | A | — | — | — |
| | 5 | 8 | B | — | — | — |
| 2 | 7 | 9 | C | 10 | 12 | R |
| | 4 | 6 | D | 1 | 3 | S |
| 3 | 7 | 6 | E | — | — | — |
| | 4 | 9 | F | — | — | — |

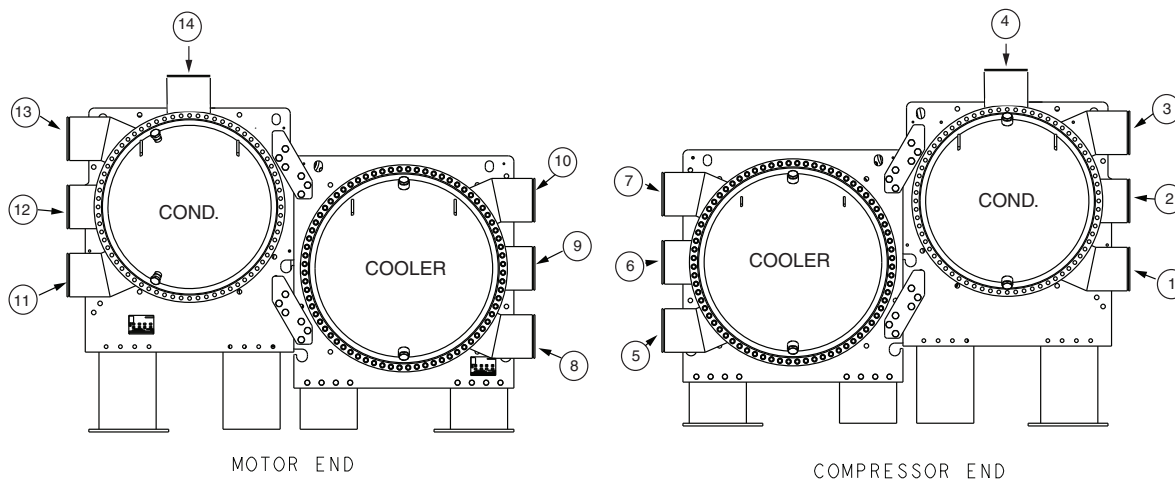

19XR TWO-STAGE COMPRESSORS FRAME SIZES 6 AND 7 FRAMES A, B, C, AND D
NOZZLE ARRANGEMENT CODES

| COOLER MARINE WATERBOXES | | | |
|--------------------------|----|-----|------------------|
| PASS | In | Out | Arrangement Code |
| 1 | 9 | 6 | A |
| | 6 | 9 | B |
| 2 | 8 | 10 | C |
| | 5 | 7 | D |
| 3 | 8 | 7 | E |
| | 5 | 10 | F |

| CONDENSER MARINE WATERBOXES | | | |
|-----------------------------|----|-----|------------------|
| PASS | In | Out | Arrangement Code |
| 1 | 12 | 2 | P |
| | 2 | 12 | Q |
| 2 | 11 | 13 | R |
| | 1 | 3 | S |
| | 11 | 14 | V |
| 3 | 1 | 4 | W |
| | 11 | 3 | T |
| | 1 | 13 | U |

Application data (cont)



RELIEF VALVE LOCATIONS

| LOCATION | FRAME SIZE | RELIEF VALVE OUTLET SIZE |
|-----------------------|--------------------------------|--------------------------------|
| COOLER | 1-2 | 1-in. NPT FEMALE CONNECTOR |
| | 3-8 | 1 1/4-in. NPT FEMALE CONNECTOR |
| | Two-Stage 6—A | 1 1/4-in. NPT FEMALE CONNECTOR |
| | Two-Stage 7—B | 1 1/4-in. NPT FEMALE CONNECTOR |
| | Two-Stage 7—C | 1 1/4-in. NPT FEMALE CONNECTOR |
| CONDENSER | 1-2 | 1-in. NPT FEMALE CONNECTOR |
| | 3-8 | 1 1/4-in. NPT FEMALE CONNECTOR |
| | Two-Stage 6—A | 1 1/4-in. NPT FEMALE CONNECTOR |
| | Two-Stage 6—B | 1 1/4-in. NPT FEMALE CONNECTOR |
| | Two-Stage 7—C | 1 1/4-in. NPT FEMALE CONNECTOR |
| Two-Stage 7—D | 1 1/4-in. NPT FEMALE CONNECTOR | |
| OPTIONAL STORAGE TANK | N/A | 1-in. NPT FEMALE CONNECTOR |

NOTE: All valves relieve at 185 psig (1275 kPa).

RELIEF VALVE ARRANGEMENT, SINGLE-STAGE COMPRESSORS AND TWO-STAGE COMPRESSOR FRAME SIZE E (Refer to page 68)

| HEAT EXCHANGER FRAME SIZE | COMPRESSOR FRAME SIZE | WITH/WITHOUT DISCHARGE ISOLATION VALVE | COOLER VIEW | CONDENSER VIEW | COOLER NO. VALVES | CONDENSER NO. VALVES |
|---------------------------|-----------------------|--|-------------|----------------|-------------------|----------------------|
| 1, 2 | 2 | With Optional Isolation Valve | A | E | 1 | 2 |
| | | Without Optional Isolation Valve | C | E | 2 | 2 |
| 3 | 2 | With Optional Isolation Valve | A | E | 1 | 2 |
| | | Without Optional Isolation Valve | C | E | 2 | 2 |
| | 3 | With Optional Isolation Valve | A | E | 1 | 2 |
| | | Without Optional Isolation Valve | C | E | 2 | 2 |
| 4 | 3 | With Optional Isolation Valve | A | E | 1 | 2 |
| | | Without Optional Isolation Valve | C | E | 2 | 2 |
| 5 | 3 | With Optional Isolation Valve | A | E | 1 | 2 |
| | | Without Optional Isolation Valve | C | E | 2 | 2 |
| | 4 | With Optional Isolation Valve | A | E | 1 | 2 |
| | | Without Optional Isolation Valve | C | E | 2 | 2 |
| 6 | 4 | With Optional Isolation Valve | A | E | 1 | 2 |
| | | Without Optional Isolation Valve | C | E | 2 | 2 |
| 7, 8 | 4, 5, E | With Optional Isolation Valve | B | F | 2 | 4 |
| | | Without Optional Isolation Valve | D | F | 4 | 4 |

RELIEF VALVE ARRANGEMENT, TWO-STAGE COMPRESSOR FRAME SIZE 6 (Refer to page 69)

| COOLER HEAT EXCHANGER FRAME SIZE* | CONDENSER HEAT EXCHANGER FRAME SIZE* | WITH/WITHOUT DISCHARGE ISOLATION VALVE | VIEW CODE | COOLER NO. VALVES | CONDENSER NO. VALVES |
|-----------------------------------|--------------------------------------|--|-----------|-------------------|----------------------|
| A4 | A4 | With Optional Isolation Valve | G | 2 | 4 |
| | | Without Optional Isolation Valve | H | 4 | 4 |
| | B4 | With Optional Isolation Valve | G | 2 | 4 |
| | | Without Optional Isolation Valve | H | 4 | 4 |
| A6 | A6 | With Optional Isolation Valve | G | 2 | 4 |
| | | Without Optional Isolation Valve | H | 4 | 4 |
| | B6 | With Optional Isolation Valve | G | 2 | 4 |
| | | Without Optional Isolation Valve | H | 4 | 4 |

*See page 8 for cooler and condenser size codes.

RELIEF VALVE ARRANGEMENT, TWO-STAGE COMPRESSOR FRAME SIZE 7 (Refer to page 69)

| COOLER HEAT EXCHANGER FRAME SIZE* | CONDENSER HEAT EXCHANGER FRAME SIZE* | WITH/WITHOUT DISCHARGE ISOLATION VALVE | VIEW CODE | COOLER NO. VALVES | CONDENSER NO. VALVES |
|-----------------------------------|--------------------------------------|--|-----------|-------------------|----------------------|
| B6 | C6 | With Optional Isolation Valve | I | 2 | 6 |
| | | Without Optional Isolation Valve | J | 4 | 6 |
| B8 | C8 | With Optional Isolation Valve | I | 2 | 6 |
| | | Without Optional Isolation Valve | J | 4 | 6 |
| C6 | C6 | With Optional Isolation Valve | I | 2 | 6 |
| | | Without Optional Isolation Valve | J | 4 | 6 |
| | D6 | With Optional Isolation Valve | I | 2 | 6 |
| | | Without Optional Isolation Valve | J | 4 | 6 |

*See page 8 for cooler and condenser size codes.

RELIEF VALVE ARRANGEMENTS

WITH OPTIONAL ISOLATION OF DISCHARGE AND COOLER

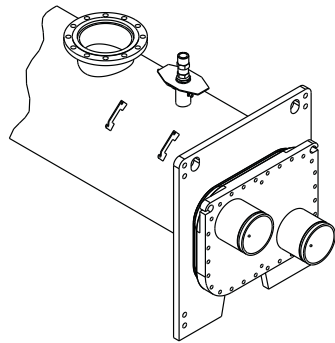

A
FRAME 1-6

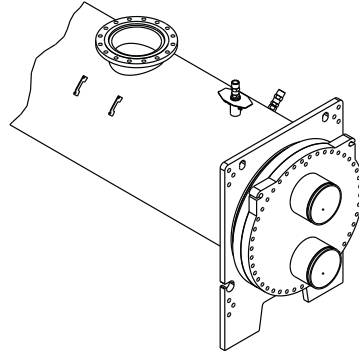

B
FRAME 7, 8

WITHOUT OPTIONAL ISOLATION OF DISCHARGE AND COOLER

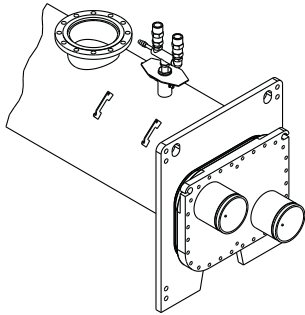

C
FRAME 1-6

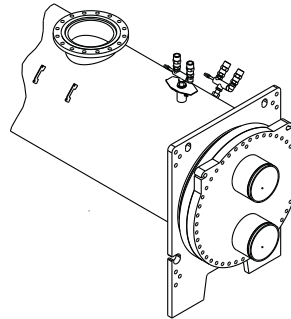

D
FRAME 7, 8

CONDENSER RELIEF VALVE ARRANGEMENT — WITH OR WITHOUT OPTIONAL ISOLATION

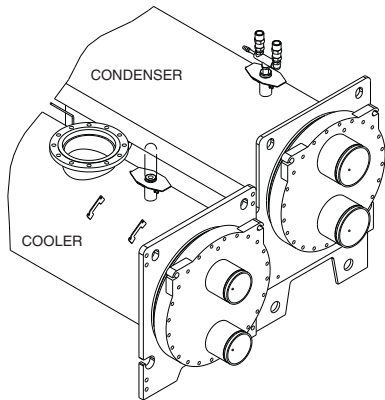

E
FRAME 1-6

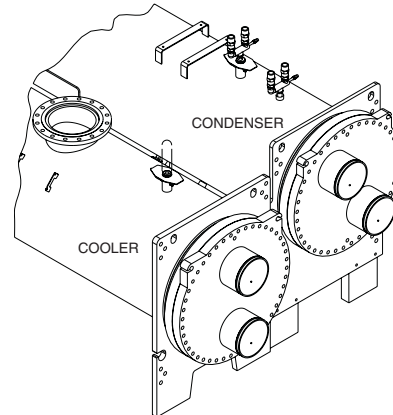

F
FRAME 7, 8

RELIEF VALVE ARRANGEMENTS (cont)

**CONDENSER RELIEF VALVE ARRANGEMENT, TWO-STAGE COMPRESSOR FRAME SIZE 6
WITH OR WITHOUT OPTIONAL ISOLATION**

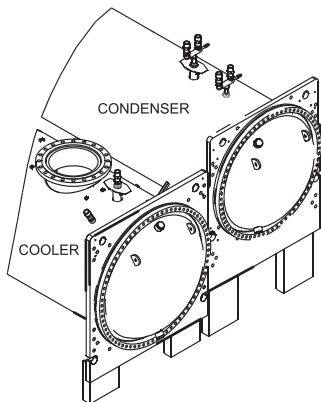

G — WITH ISOLATION VALVE

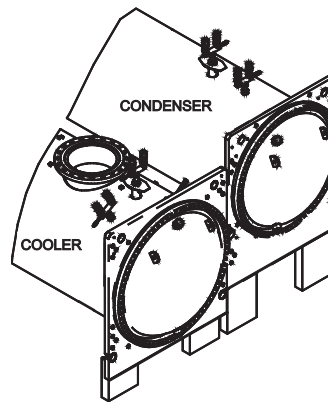

H — WITHOUT ISOLATION VALVE

**CONDENSER RELIEF VALVE ARRANGEMENT, TWO-STAGE COMPRESSOR FRAME SIZE 7
WITH OR WITHOUT OPTIONAL ISOLATION**

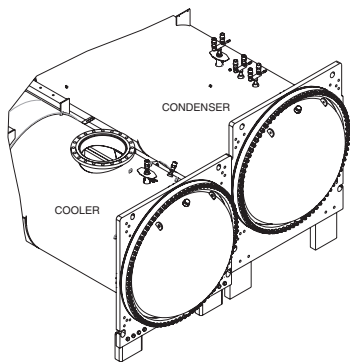

I — WITH ISOLATION VALVE

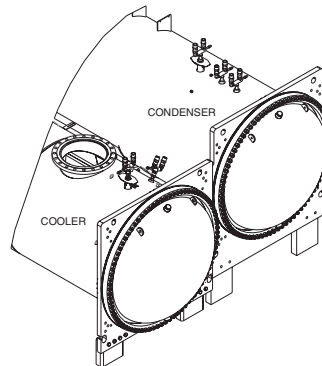

J — WITHOUT ISOLATION VALVE

Application data (cont)



Vent and drain connections

Nozzle-in-head waterboxes have vent and drain connections on covers. Marine waterboxes have vent and drain connections on waterbox shells.

Provide high points of the chiller piping system with vents and the low points with drains. If shutoff valves are provided in the main water pipes near the unit, a minimal amount of system water is lost when the heat exchangers are drained. This reduces the time required for drainage and saves on the cost of re-treating the system water.

It is recommended that pressure gages be provided at points of entering and leaving water to measure pressure drop through the heat exchanger. Gages may be installed as shown in Pressure Gage Location table. Pressure gages installed at the vent and drain connections do not include nozzle pressure losses.

Use a reliable differential pressure gage to measure pressure differential when determining water flow. Regular gages of the required pressure range do not have the accuracy to provide accurate measurement of flow conditions.

PRESSURE GAGE LOCATION

| NUMBER OF PASSES | GAGE LOCATION (Cooler or Condenser) |
|------------------|-------------------------------------|
| 1 or 3 | One gage in each waterbox |
| 2 | Two gages in waterbox with nozzles |

ASME stamping

All 19XR,XRV heat exchangers are constructed in accordance with ASHRAE (American Society of Heating, Refrigerating, and Air-Conditioning Engineers) 15 Safety Code for Mechanical Refrigeration (latest edition). This code, in turn, requires conformance with ASME (American Society of Mechanical Engineers) Code for Unfired Pressure Vessels wherever applicable.

Each vessel is constructed and certified in accordance with ASME Section 8, Division 1.

Relief valve discharge pipe sizing

See pages 66 and 67 for number of relief valves and locations.

Relief-valve discharge piping size should be calculated per ASHRAE 15, latest edition, code using the tabulated C factors for each vessel shown in the tables on pages 71 and 72.

Carrier further recommends that an oxygen sensor be installed to protect personnel. Sensor should be able to sense the depletion or displacement of oxygen in the machine room below 19.5% volume oxygen per ASHRAE 15, latest edition.

19XR,XRV RELIEF VALVE DISCHARGE PIPE SIZING, SINGLE-STAGE COMPRESSORS AND TWO-STAGE COMPRESSORS FRAME SIZE E

| HEAT EXCHANGER | FRAME SIZE | VESSEL REQUIRED C FACTOR (lb air/Min) | RELIEF VALVE RATED C FACTOR (lb air/Min) | FIELD CONNECTION SIZE (FPT) |
|--------------------------------|--------------------------------|---|--|--------------------------------|
| COOLER | 10 to 12 | 30.0 | 48.4 | 1" |
| | 15 to 17 | 36.0 | 48.4 | 1" |
| | 20 to 22 | 35.7 | 48.4 | 1" |
| | 30 to 32 | 43.8 | 72.1 | 1 1/4" |
| | 35 to 37 | 49.9 | 72.1 | 1 1/4" |
| | 40 to 42 | 50.4 | 72.1 | 1 1/4" |
| | 45 to 47 | 57.4 | 72.1 | 1 1/4" |
| | 50 to 54, 5A-5C, 5K-5R | 53.7 | 72.1 | 1 1/4" |
| | 55 to 59, 5F-5H, 5T-5Z | 61.1 | 72.1 | 1 1/4" |
| | 60 to 64, 6K to 6R | 57.0 | 72.1 | 1 1/4" |
| | 65 to 69, 6T to 6Z | 64.9 | 72.1 | 1 1/4" |
| | 70 to 74, 7K to 7R | 77.0 | 144.2 | 1 1/4" |
| | 75 to 79, 7T to 7Z | 88.0 | 144.2 | 1 1/4" |
| | 80 to 84, 8K to 8R | 87.7 | 144.2 | 1 1/4" |
| 85 to 89, 8T to 8Z | 100.3 | 144.2 | 1 1/4" | |
| CONDENSER | 10 to 12 | 31.7 | 48.4 | 1" |
| | 15 to 17 | 38.0 | 48.4 | 1" |
| | 20 to 22 | 34.0 | 48.4 | 1" |
| | 30 to 32 | 41.8 | 72.1 | 1 1/4" |
| | 35 to 37 | 47.6 | 72.1 | 1 1/4" |
| | 40 to 42 | 47.1 | 72.1 | 1 1/4" |
| | 45 to 47 | 53.7 | 72.1 | 1 1/4" |
| | 50 to 54 | 51.2 | 72.1 | 1 1/4" |
| | 55 to 59 | 58.3 | 72.1 | 1 1/4" |
| | 60 to 64 | 55.3 | 72.1 | 1 1/4" |
| | 65 to 69 | 63.0 | 72.1 | 1 1/4" |
| | 70 to 74 Compressor Frame 5 | 72.3 | 144.2 | 1 1/4" |
| | 75 to 79 Compressor Frame 5 | 82.7 | 144.2 | 1 1/4" |
| | 80 to 84 Compressor Frame 5 | 80.7 | 144.2 | 1 1/4" |
| | 85 to 89 Compressor Frame 5 | 92.3 | 144.2 | 1 1/4" |
| | 70 to 74 Compressor Frame E | 88.3 | 144.2 | 1 1/4" |
| | 75 to 79 Compressor Frame E | 98.7 | 144.2 | 1 1/4" |
| | 80 to 84 Compressor Frame E | 96.7 | 144.2 | 1 1/4" |
| 85 to 89 Compressor Frame E | 108.3 | 144.2 | 1 1/4" | |

Application data (cont)



19XR RELIEF VALVE DISCHARGE PIPE SIZING, TWO-STAGE COMPRESSORS FRAME SIZE 6 AND 7

| HEAT EXCHANGER | FRAME SIZE | VESSEL REQUIRED C FACTOR (lb air/Min) | COMBINED RELIEF VALVES RATED C FACTOR (lb air/Min) | FIELD CONNECTION SIZE (FPT) |
|--------------------------|------------|---------------------------------------|--|-----------------------------|
| COOLER | A40 to A47 | 95.2 | 144.2 | 1 1/4" |
| | A60 to A67 | 108.8 | 144.2 | 1 1/4" |
| | A4A to A4H | 95.2 | 144.2 | 1 1/4" |
| | A6A to A6H | 108.8 | 144.2 | 1 1/4" |
| | B60 to B67 | 123.7 | 144.2 | 1 1/4" |
| | B6A to B6H | 123.7 | 144.2 | 1 1/4" |
| | B80 to B87 | 139.2 | 144.2 | 1 1/4" |
| | B8A to B8H | 139.2 | 144.2 | 1 1/4" |
| | C60 to C67 | 138.7 | 144.2 | 1 1/4" |
| C6A to C6H | 138.7 | 144.2 | 1 1/4" | |
| CONDENSER AND ECONOMIZER | A40 to A47 | 110.1* | 144.2 | 1 1/4" |
| | A60 to A67 | 122.7* | 144.2 | 1 1/4" |
| | A4A to A4H | 110.1* | 144.2 | 1 1/4" |
| | A6A to A6H | 122.7* | 144.2 | 1 1/4" |
| | B40 to B47 | 120.9* | 144.2 | 1 1/4" |
| | B60 to B67 | 134.9* | 144.2 | 1 1/4" |
| | B4A to B4H | 120.9* | 144.2 | 1 1/4" |
| | B6A to B6H | 134.9* | 144.2 | 1 1/4" |
| | C60 to C67 | 164.7* | 216.3 | 1 1/4" |
| | C6A to C6H | 164.7* | 216.3 | 1 1/4" |
| | C80 to C87 | 186.2* | 216.3 | 1 1/4" |
| | C8A to C8H | 186.2* | 216.2 | 1 1/4" |
| | D60 to D67 | 187.8* | 216.3 | 1 1/4" |
| D6A to D6H | 187.8* | 216.3 | 1 1/4" | |

*The condenser discharge required C factor is the combined values of the condenser, high-side float, and economizer.

Design pressures

Design and test pressures for heat exchangers are listed below.

DESIGN AND MINIMUM TEST PRESSURES

| VESSEL | PRESSURES | SHELL SIDE (Refrigerant) | | STANDARD TUBE SIDE (Water) | | OPTIONAL TUBE SIDE (Water) | |
|------------------------------------|----------------------------|--------------------------|------|----------------------------|------|----------------------------|------|
| | | psig | kPa | psig | kPa | psig | kPa |
| Cooler | Design | 185 | 1276 | 150 | 1034 | 300 | 2068 |
| | Leak Test (min) | 185 | 1276 | 150 | 1034 | 300 | 2068 |
| | Hydrostatic Test | — | — | 195 | 1344 | 390 | 2690 |
| | Proof Test (min Pneumatic) | 204 | 1407 | — | — | — | — |
| Condenser | Design | 185 | 1276 | 150 | 1034 | 300 | 2068 |
| | Leak Test (min) | 185 | 1276 | 150 | 1034 | 300 | 2068 |
| | Hydrostatic Test | — | — | 195 | 1344 | 390 | 2690 |
| | Proof Test (min Pneumatic) | 204 | 1407 | — | — | — | — |
| Economizer Frame Size E | Design | 185 | 1276 | — | — | — | — |
| | Leak Test (min) | 185 | 1276 | — | — | — | — |
| | Hydrostatic Test | — | — | — | — | — | — |
| | Proof Test (min Pneumatic) | 204 | 1407 | — | — | — | — |
| Economizer, Frame Sizes 6 and 7 | Design | 185 | 1276 | — | — | — | — |
| | Leak Test (min) | 185 | 1276 | — | — | — | — |
| | Hydrostatic Test | — | — | — | — | — | — |
| | Proof Test (min Pneumatic) | 204 | 1407 | — | — | — | — |

HEAT EXCHANGER MATERIAL SPECIFICATIONS

| ITEM | MATERIAL | SPECIFICATION |
|---------------------------|---------------------|-----------------------------|
| Shell | HR Steel | ASME SA516 GR .70 |
| Tube Sheet | HR Steel | ASME SA516 GR .70 |
| Flat Covers | HR Steel | ASME/ASTM A516 GR.70 |
| Pipe | Steel | ASME SA106 GRB/SA53 E/B |
| Flanges | Steel | ASME B16.5 |
| Condenser Float Box Shell | Steel | ASME SA53 E/B |
| Tubes | Per Job Requirement | ASME SB359 |
| Dished Cover | HR Steel | ASTM A516 GR.70/GB713 Q345R |
| Marine Water Box Shell | HR Steel | ASME/ASTM A516 GR.70 |

ECONOMIZER MATERIAL SPECIFICATIONS

| ITEM | MATERIAL | SPECIFICATION |
|-------|----------|------------------|
| Shell | Steel | ASME SA53 E/B |
| Cover | HR Steel | ASME SA516 GR.70 |
| Pipe | Steel | ASME SA106 GR.70 |

LEGEND

ASME — American Society of Mechanical Engineers
ASTM — American Society for Testing and Materials
HR — Hot Rolled

Insulation

Factory insulation (optional)* — The factory insulation option for the 19XR,XRV chillers include the following areas: cooler (not including waterbox); suction line up to the compressor suction housing; compressor motor and motor cooling return lines; several small oil cooling and oil return system lines; the liquid line; the float chamber; and VFD refrigerant drain lines (19XRV units only). For two-stage chillers, factory insulation also includes economizer and economizer piping. Insulation applied at the factory is $\frac{3}{4}$ in. (19 mm) thick and has a thermal conductivity K value of 0.28 (Btu in.)/hr ft² °F [(0.0404 • W)/(m • °C)]. Insulation conforms with Underwriters Laboratories (UL) Standard 94, Classification 94HBF.

*On compressor frame sizes 6 and 7 the condenser is insulated as standard.

MINIMUM FIELD-INSTALLED INSULATION REQUIREMENTS*

| CHILLER | HEAT EXCHANGER SIZE | INSULATION* | |
|---|---------------------|-----------------|----------------|
| | | ft ² | m ² |
| 19XR,XRV Single-Stage and Two-Stage Frame Size E | 10-12 | 75 | 6.9 |
| | 15-17 | 85 | 7.9 |
| | 20-22 | 100 | 9.3 |
| | 30-32 | 125 | 11.7 |
| | 35-37 | 135 | 12.6 |
| | 40-42 | 155 | 14.4 |
| | 45-47 | 170 | 15.8 |
| | 50-54, 5A-5C, 5K-5R | 170 | 15.8 |
| | 55-59, 5F-5H, 5T-5Z | 185 | 17.2 |
| | 60-64, 6K-6R | 185 | 17.2 |
| | 65-69, 6T-6Z | 205 | 19.1 |
| | 70-74, 7K-7R | 260 | 24.2 |
| | 75-79, 7T-7Z | 295 | 27.4 |
| | 80-84, 8K-8R | 310 | 28.8 |
| | 85-89, 8T-8Z | 355 | 32.9 |

| CHILLER | COOLER FRAME SIZE | INSULATION† | |
|------------------------------------|------------------------|-----------------|----------------|
| | | ft ² | m ² |
| 19XR Two-Stage Frame Size 6 | A40-A47 and A4A-A4H | 434 | 40.3 |
| | A60-A67 and A6A-A6H | 462 | 42.9 |
| 19XR Two-Stage Frame Size 7 | B60-B67 and B6A-B6H | 666 | 61.9 |
| | B80-B87 and B8A to B8H | 699 | 64.9 |
| | C60-C67 and C6A-C6H | 694 | 64.9 |

*Add 50 sq ft additional insulation for economizer on two-stage chiller.
 †Factory installed as shown on page 76.

NOTE: Insulation amount includes only the amount of insulation required to insulate the sections of the chiller that would be included in the factory-installed insulation option.

Application data (cont)



Insulation at jobsite — As indicated in the Condensation vs Relative Humidity table, the factory insulation provides excellent protection against condensation under most operating conditions. If temperatures in the equipment area exceed the maximum design conditions, extra insulation is recommended.

If the machine is to be field insulated, obtain the approximate areas from the Minimum Field-Installed Insulation Requirements table.

Insulation of waterbox is made only in the field and this area is not included in Minimum Field-Installed Insulation Requirements table. When insulating the covers, allow for service access and removal of covers. To estimate waterbox cover areas refer to certified drawings.

High humidity jobsite locations may require field supplied and installed insulation on the float chamber, suction housing, and the lower half of the condenser.

CONDENSATION VS RELATIVE HUMIDITY*

| AMOUNT OF CONDENSATION | ROOM DRY-BULB TEMP | | |
|------------------------|---------------------|-------------|--------------|
| | 80 F (27 C) | 90 F (32 C) | 100 F (38 C) |
| | % Relative Humidity | | |
| None | 80 | 76 | 70 |
| Slight | 87 | 84 | 77 |
| Extensive | 94 | 91 | 84 |

*These approximate figures are based on 35 F (1.7 C) saturated suction temperature. A 2° F (1.1° C) change in saturated suction temperature changes the relative humidity values by 1% in the same direction.

Unit location — Chiller should be installed in an indoor environment where the ambient temperature is 40 to 104 F (4 to 40 C) with a relative humidity (non-condensing) of 95% or less. To ensure that electrical components operate properly, do not locate the chiller in an area exposed to dust, dirt, corrosive fumes, or excessive heat and humidity.

19XR,XRV FACTORY-INSTALLED INSULATION AREA SINGLE-STAGE CHILLER

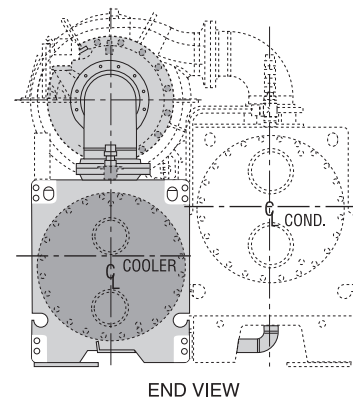
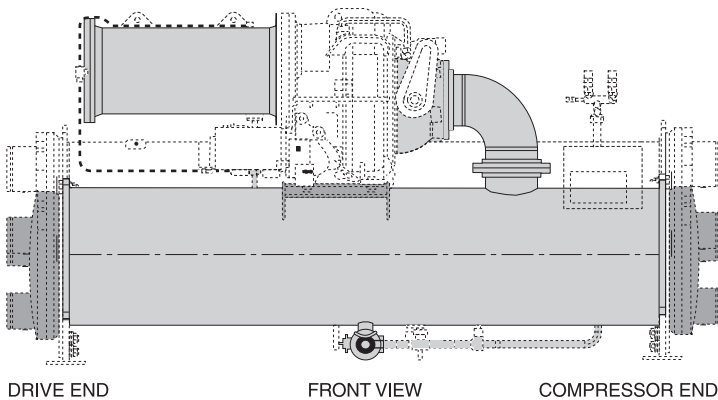
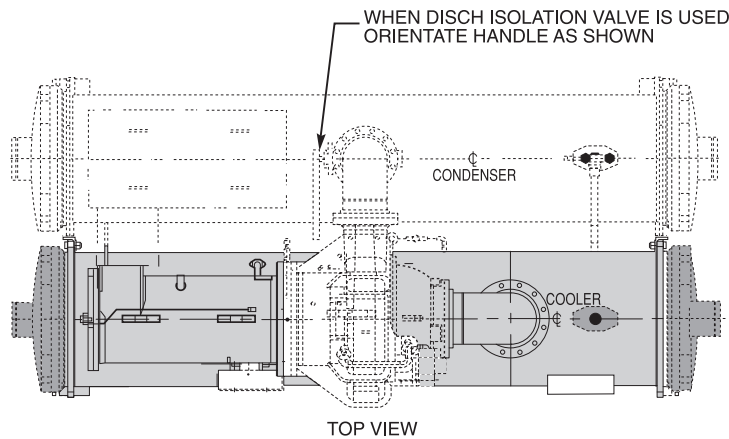

FACTORY INSTALLED INSULATION
 FIELD SUPPLIED AND INSTALLED INSULATION (IF REQUIRED)

**19XR,XRV FACTORY-INSTALLED INSULATION AREA (cont)
TWO-STAGE CHILLER FRAME E**

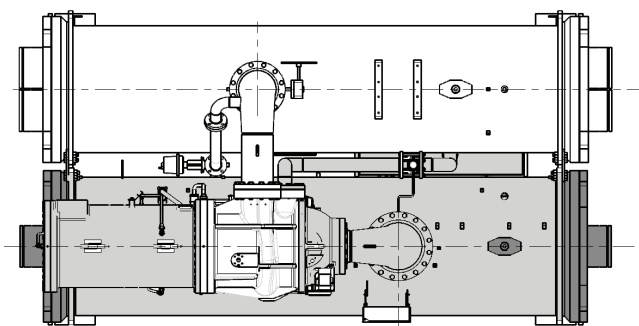

TOP VIEW

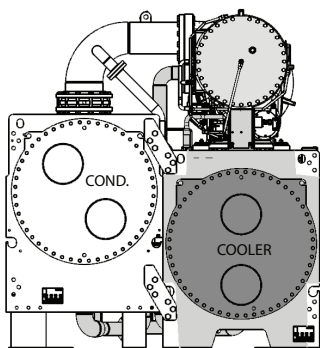

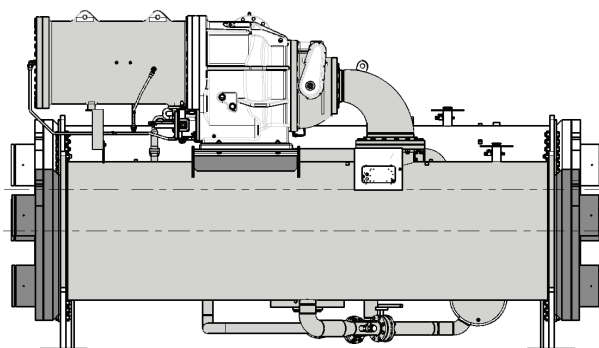

DRIVE END VIEW

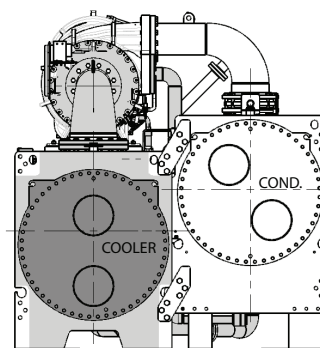

FRONT VIEW



COMPRESSOR END VIEW

-  FACTORY INSTALLED INSULATION
-  FIELD SUPPLIED AND INSTALLED INSULATION (IF REQUIRED)

19XR FACTORY-INSTALLED INSULATION AREA TWO-STAGE CHILLER FRAME SIZES 6 AND 7

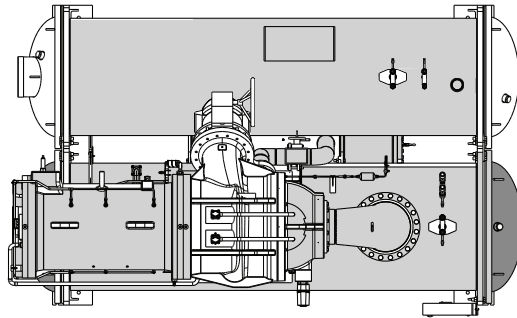

TOP VIEW

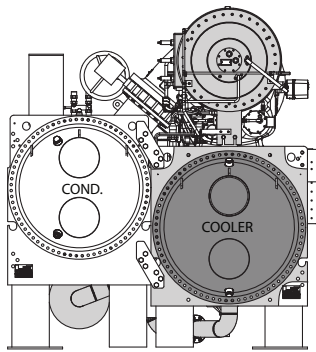

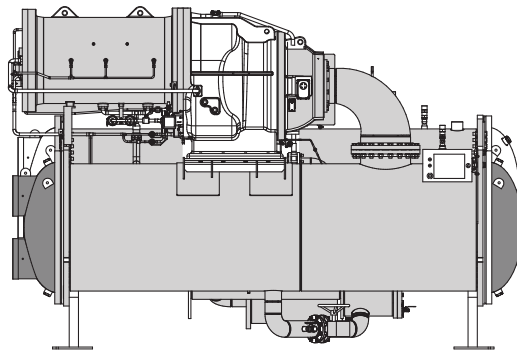

DRIVE END VIEW

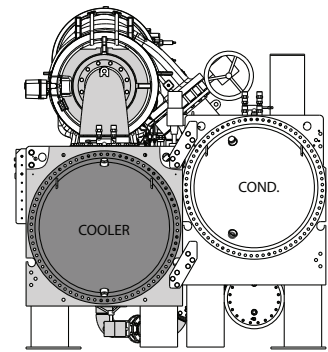

FRONT VIEW



COMPRESSOR END VIEW

-  FACTORY INSTALLED INSULATION
-  FIELD SUPPLIED AND INSTALLED INSULATION (IF REQUIRED)

NOTE: Compressor frame size 6 is shown.

Packaged Semi-Hermetic Centrifugal Liquid Chiller

HVAC Guide Specifications — 19XR, XRV

Size Range:

19XR,XRV — 200 to 3000 Tons (703 to 10551 kW) Nominal

Carrier Model Number:

19XR,XRV

Part 1 — General

1.01 SYSTEM DESCRIPTION

- A. Microprocessor-controlled liquid chiller shall use a semi-hermetic centrifugal compressor using refrigerant HFC-134a.
- B. If a manufacturer proposes a liquid chiller using HCFC-123 refrigerant, then the manufacturer shall include in the chiller price:
 1. A vapor activated alarm system shall be capable of responding to HCFC-123 levels of 10 ppm Allowable Exposure Limit (AEL).
 2. External refrigerant storage tank and pumpout unit.
 3. Zero emission purge unit capable of operating even when the chiller is not operating.
 4. Back-up relief valve to rupture disk.
 5. Chiller pressurizing system to prevent leakage of noncondensables into chiller during shut-down periods.
 6. Plant room ventilation.

1.02 QUALITY ASSURANCE

- A. Chiller performance shall be rated in accordance with AHRI (Air-Conditioning, Heating and Refrigeration Institute) Standard 550/590, latest edition.
- B. Equipment and installation shall be in compliance with ANSI/ASHRAE (American National Standards Institute/American Society of Heating, Refrigerating and Air-Conditioning Engineers) 15 (latest edition).
- C. Cooler and condenser refrigerant side shall include ASME “U” stamp and nameplate certifying compliance with ASME Section VIII, Division 1 code for unfired pressure vessels.
- D. Chiller shall be designed and constructed to meet UL (Underwriters Laboratories) and UL, Canada requirements and have labels appropriately affixed.
- E. Centrifugal compressor impellers shall be dynamically balanced and over-speed tested by the manufacturer at a minimum of 120% design operating speed. Each compressor assembly shall undergo a mechanical run-in test to verify vibration levels, oil pressures, and temperatures are within acceptable limits.

Each compressor assembly shall be proof tested at a minimum 204 psig (1406 kPa) and leak tested at 185 psig (1276 kPa) with a tracer gas mixture.

- F. Entire chiller assembly shall be proof tested at 204 psig (1406 kPa) and leak tested at 185 psig (1276 kPa) with a tracer gas mixture on the refrigerant side. The water side of each heat exchanger shall be hydrostatically tested at 1.3 times rated working pressure.
- G. Prior to shipment, the chiller automated controls test shall be executed to check for proper wiring and ensure correct controls operation.
- H. On chillers with unit-mounted compressor motor starter or VFD (variable frequency drive), the chiller and starter/VFD shall be factory wired and tested together to verify proper operation prior to shipment.
 - I. The management system governing the manufacture of this chiller shall be ISO 9001:2008 certified.

1.03 DELIVERY, STORAGE AND HANDLING

- A. Unit shall be stored and handled in accordance with manufacturer's instructions.
- B. Unit shall be shipped with all refrigerant piping and control wiring factory installed.
- C. Unit shall be shipped charged with oil and full charge of refrigerant HFC-134a or a nitrogen holding charge as specified on the equipment schedule.
- D. Unit shall be shipped with firmly attached labels that indicate name of manufacturer, chiller model number, chiller serial number, and refrigerant used.
- E. If the chiller is to be exported, the unit shall be sufficiently protected from the factory against sea water corrosion to be suitable for shipment in a standard open top, ocean shipping container (19XR,XRV heat exchanger frames 1 through 6 only).

1.04 WARRANTY

Warranty shall include parts and labor for one year after start-up or 18 months from shipment, whichever occurs first.

Part 2 — Products

2.01 EQUIPMENT

A. General:

Factory assembled, single piece, liquid chiller shall consist of compressor, motor, starter or variable frequency drive, lubrication system, cooler, condenser, initial oil and refrigerant operating charges, microprocessor control system, and documentation required prior to start-up. An optional compressor motor starter or VFD can be mounted on the chiller, wired, and tested by the chiller manufacturer (select models). Or, an optional free-standing medium voltage starter or VFD can be wired and tested by the chiller manufacturer.

B. Compressor:

1. One high performance centrifugal compressor.
2. Compressor, motor, and transmission shall be semi-hermetically sealed into a common assembly and arranged for easy field servicing.

3. Internal compressor parts must be accessible for servicing without removing the compressor base from the chiller. Connections to the compressor casing shall use O-rings instead of gaskets to reduce the occurrence of refrigerant leakage. Connections to the compressor shall be flanged or bolted for easy disassembly.
 4. All pressure transducers shall have quick disconnects to allow replacement of the sensor without replacement of the entire sensor wire. Pressure transducers shall be capable of field calibration to ensure accurate readings and to avoid unnecessary transducer replacement. Pressure transducers and temperature sensors shall be serviceable without the need for refrigerant charge removal or isolation.
 5. Transmission shall be helical, parallel shaft speed increaser. Gears shall conform to AGMA 2001-B88, Class 11.
 6. Journal bearings shall be of the steel backed babbit lined type. Aluminum journal bearings are not acceptable. The thrust bearing shall be tilting pad or rolling element type.
 7. Centrifugal compressors shall use variable inlet guide vanes to provide capacity modulation while also providing pre-whirl of the refrigerant vapor entering the impeller for more efficient compression at all loads.
 8. Centrifugal compressors shall be provided with a factory-installed lubrication system to deliver oil under pressure to bearings and transmission. Included in the system shall be:
 - a. Hermetic driven oil pump with factory-installed motor contactor with overload protection.
 - b. Refrigerant-cooled oil cooler. Water-cooled oil coolers are not acceptable.
 - c. Oil pressure regulator.
 - d. Oil filter with isolation valves to allow filter change without removal of refrigerant charge.
 - e. Oil sump heater controlled from unit microprocessor.
 - f. Oil reservoir temperature sensor with main control center digital readout.
 - g. When factory-mounted compressor motor starter or VFD is provided, all wiring to oil pump, oil heater, and controls shall be pre-wired in the factory.
 - h. Compressor shall be fully field serviceable. Compressors which must be removed and returned to the factory for service shall be unacceptable.
- C. Motor:
1. Compressor motor shall be of the semi-hermetic, liquid refrigerant cooled, squirrel cage, induction type suitable for voltage shown on the equipment schedule.
 2. If an open drive motor is provided, a compressor shaft seal leakage containment system shall be provided.
 - a. An oil reservoir shall collect oil and refrigerant that leaks past the seal.
 - b. A float device shall be provided to open when the reservoir is full, directing the refrigerant/oil mixture back into the compressor housing.
 - c. A refrigerant sensor shall be located next to the open drive seal to detect leaks.
 3. Motors shall be suitable for operation in a refrigerant atmosphere and shall be cooled by atomized refrigerant in contact with the motor windings.
 4. Motor stator shall be arranged for service or removal with only minor compressor disassembly and without removing main refrigerant piping connections.
 5. Full load operation of the motor shall not exceed nameplate rating.
 6. At least one motor winding temperature sensor (and one spare) shall be provided.
 7. Should the mechanical contractor choose to provide a chiller with an open motor instead of the specified semi-hermetic motor, the contractor shall install additional cooling equipment to dissipate the motor heat as per the following formula:
$$Btuh = (FLkW \text{ motor}) (0.05) (3413)$$
$$Btuh = (FLkW \text{ motor}) (171)$$
and, alternately
$$\text{Tons} = Btuh / 12,000$$
The additional piping, valves, air-handling equipment, insulation, wiring, switchgear changes, ductwork, and coordination with other trades shall be the responsibility of the mechanical contractor. Shop drawings reflecting any changes to the design shall be included in the submittal, and incorporated into the final as-built drawings for the project.
 8. Also, if an open motor is provided, a mechanical room thermostat shall be provided and set at 104 F (40 C). If this temperature is exceeded, the chillers shall shut down and an alarm signal shall be generated to the central Energy Management System (EMS) display module prompting the service personnel to diagnose and repair the cause of the over temperature condition. The mechanical contractor shall be responsible for all changes to the design, including coordination with temperature control, electrical and other trades. In addition, the electrical power consumption of any auxiliary ventilation and/or mechanical cooling required to maintain the mechanical room conditions stated above shall be considered in the

determination of conformance to the scheduled chiller energy efficiency requirement.

D. Cooler and Condenser:

1. Cooler shall be of shell and tube type construction, each in separate shells. Units shall be fabricated with high-performance tubing, minimum 1/4 in. (6 mm) steel shell and tube sheets with fabricated steel waterboxes.
 - a. Waterbox shall be nozzle-in-head waterbox (150 psig [1034 kPa]).
 - b. Waterbox shall have standard Victaulic grooves. For 19XR with Frame 6 or Frame 7 compressor, the Victaulic AGS grooves shall be provided for nominal 14-in. pipe and larger.
2. Condenser shall be of shell and tube type construction, each in separate shells. Units shall be fabricated with high-performance tubing, minimum 1/4 in. (6 mm) steel shell and tube sheets with fabricated steel waterboxes.
 - a. Waterbox shall be nozzle-in-head (150 psig [1034 kPa]).
 - b. Waterbox shall have standard Victaulic grooves. For 19XR with Frame 6 or Frame 7 compressor, the Victaulic AGS grooves shall be provided for nominal 14-in. pipe and larger.
3. Waterboxes shall have vents, drains, and covers to permit tube cleaning within the space shown on the drawings. A thermistor type temperature sensor with quick connects shall be factory installed in each water nozzle.
4. Tubes shall be individually replaceable from either end of the heat exchanger without affecting the strength and durability of the tube sheet and without causing leakage in adjacent tubes.
5. Tubing shall be copper, high-efficiency type, with integral internal and external enhancement unless otherwise noted. Tubes shall be nominal 3/4-in. or 1 in. OD with nominal wall thickness of 0.025 in. measured at the root of the fin at the enhanced areas and nominal wall thickness of 0.049 in. where the tubes are in contact with the end tube sheets unless otherwise noted. Tubes shall be rolled into tube sheets and shall be individually replaceable. Tube sheet holes shall be double grooved for joint structural integrity.
6. Cooler shall be designed to prevent liquid refrigerant from entering the compressor.
7. The condenser shell shall include a FLASC (flash subcooler) which cools the condensed liquid refrigerant to a reduced temperature, thereby increasing the refrigeration cycle efficiency.
8. A reseating type pressure relief valve shall be installed on each heat exchanger. If a non-reseating type is used, a backup reseating type

shall be installed in series.

E. Refrigerant Flow Control:

1. To maintain optimal part load efficiency, the refrigerant expansion device to the cooler and as applicable to the economizer, shall use a variable metering valve, such as a float or actuated valve. To ensure good operating performance, the valve design will prevent refrigerant gas from the condenser from passing to the cooler or economizer at full or part load.
2. By maintaining a liquid seal at the flow valve, bypassed hot gas from the condenser to the cooler is eliminated. The float valve chamber shall have a bolted access cover to allow field inspection and the float valve shall be field serviceable.

F. Controls, Safeties, and Diagnostics:

1. Controls:
 - a. The chiller shall be provided with a factory installed and wired microprocessor control center. The microprocessor can be configured for either English or SI units.
 - b. All chiller and starter monitoring shall be displayed at the chiller control panel.
 - c. The controls shall make use of non-volatile memory.
 - d. The chiller control system shall have the ability to interface and communicate directly to the building control system.
 - e. The default standard display screen shall simultaneously indicate the following minimum information:
 - 1) date and time of day
 - 2) 24-character primary system status message
 - 3) 24-character secondary status message
 - 4) chiller operating hours
 - 5) entering chilled water temperature
 - 6) leaving chilled water temperature
 - 7) evaporator refrigerant temperature
 - 8) entering condenser water temperature
 - 9) leaving condenser water temperature
 - 10) condenser refrigerant temperature
 - 11) oil supply pressure
 - 12) oil sump temperature
 - 13) percent motor rated load amps (RLA)
 - f. In addition to the default screen, status screens shall be accessible to view the status of every point monitored by the control center including:
 - 1) evaporator pressure
 - 2) condenser pressure
 - 3) bearing oil supply temperature
 - 4) compressor discharge temperature
 - 5) motor winding temperature
 - 6) number of compressor starts
 - 7) control point settings
 - 8) discrete output status of various devices

- 9) compressor motor starter status
- 10) optional spare input channels
- 11) current and voltage for each phase
- 12) frequency

g. Schedule Function:

The chiller controls shall be configurable for manual or automatic start-up and shutdown. In automatic operation mode, the controls shall be capable of automatically starting and stopping the chiller according to a stored user programmable occupancy schedule. The controls shall include built-in provisions for accepting:

- 1) A minimum of two 365-day occupancy schedules.
- 2) Minimum of 8 separate occupied/unoccupied periods per day.
- 3) Daylight savings start/end.
- 4) Minimum of 18 user-defined holidays.
- 5) Means of configuring an occupancy timed override.
- 6) Chiller start-up and shutdown via remote contact closure.

h. Service Function:

The controls shall provide a password protected service function which allows authorized individuals to view an alarm history file which shall contain the last 25 alarm/alert messages with time and date stamp. These messages shall be displayed in text form, not codes.

i. Network Window Function:

Each chiller control panel shall be capable of viewing multiple point values and statuses from other like controllers connected on a common network, including controller maintenance data. The operator shall be able to alter the remote controller's set points or time schedule and to force point values or statuses for those points that are operator forcible. The control panel shall also have access to the alarm history file of all like controllers connected on the network.

j. Pump Control:

Upon request to start the compressor, the control system shall start the chilled water pump, condenser water pumps and verify that flows have been established.

k. Ramp Loading:

A user-configurable ramp loading rate, effective during the chilled water temperature pulldown period, shall control the rate of guide vane opening to prevent a rapid increase in compressor power consumption. The controls shall allow configuration of the ramp loading rate in either degrees/minute of chilled water temperature pulldown or percent motor amps/minute. During the ramp loading period, a message shall be

displayed informing the operator that the chiller is operating in ramp loading mode.

l. Chilled Water Reset:

The control center shall allow reset of the chilled water temperature set point based on any one of the following criteria:

- 1) Chilled water reset based on an external 4 to 20 mA signal.
- 2) Chilled water reset based on a remote temperature sensor (such as outdoor air).
- 3) Chilled water reset based on water temperature rise across the evaporator.

m. Demand Limit:

The control center shall limit amp draw of the compressor to the rated load amps or to a lower value based on one of the following criteria:

- 1) Demand limit based on a user input ranging from 40% to 100% of compressor rated load amps.
- 2) Demand limit based on external 4 to 20 mA signal.

n. Controlled Compressor Shutdown:

The controls shall be capable of being configured to soft stop the compressor. When the stop button is pressed or remote contacts open with this feature active, the guide vanes shall close to a configured amperage level and the machine shall then shut down. The display shall indicate "shutdown in progress."

2. Safeties:

a. Unit shall automatically shut down when any of the following conditions occur: (Each of these protective limits shall require manual reset and cause an alarm message to be displayed on the control panel screen, informing the operator of the shutdown cause.)

- 1) motor overcurrent
- 2) over voltage*
- 3) under voltage*
- 4) single cycle dropout*
- 5) bearing oil high temperature
- 6) low evaporator refrigerant temperature
- 7) high condenser pressure
- 8) high motor temperature
- 9) high compressor discharge temperature
- 10) low oil pressure
- 11) prolonged surge
- 12) loss of cooler water flow
- 13) loss of condenser water flow
- 14) starter fault

*Shall not require manual reset or cause an alarm if auto-restart after power failure is enabled.

- b. The control system shall detect conditions that approach protective limits and take self-corrective action prior to an alarm occurring. The system shall automatically reduce chiller capacity when any of the following parameters are outside their normal operating range:
 - 1) high condenser pressure
 - 2) high motor temperature
 - 3) low evaporator refrigerant temperature
 - 4) surge prevention control
 - 5) high motor amps.
 - c. During the capacity override period, a pre-alarm (alert) message shall be displayed informing the operator which condition is causing the capacity override. Once the condition is again within acceptable limits, the override condition shall be terminated and the chiller shall revert to normal chilled water control. If during either condition the protective limit is reached, the chiller shall shut down and a message shall be displayed informing the operator which condition caused the shutdown and alarm.
 - d. Internal built-in safeties shall protect the chiller from loss of water flow. Differential pressure switches shall not be allowed to be the only form of freeze protection.
3. Diagnostics and Service:
- a. A self diagnostic controls test shall be an integral part of the control system to allow quick identification of malfunctioning components.
 - b. Once the controls test has been initiated, all pressure and temperature sensors shall be checked to ensure they are within normal operating range. A pump test shall automatically energize the chilled water pump, condenser water pump, and oil pump. The control system shall confirm that water flow and oil pressure have been established and require operator confirmation before proceeding to the next test. A guide vane actuator test shall open and close the guide vanes to check for proper operation. The operator manually acknowledges proper guide vane operation prior to proceeding to the next test.
 - c. In addition to the automated controls test, the controls shall provide a manual test which permits selection and testing of individual control components and inputs. A thermistor test and transducer test shall display and an actual reading shall be performed for each transducer and each thermistor installed on the chiller. All out-of-range sensors shall be identified.
4. Multiple Chiller Control:
- The chiller controls shall be supplied as standard with a two-chiller lead/lag and a third chiller standby system. The control system shall automatically start and stop a lag or second chiller on a two-chiller system. If one of the two chillers on line goes into a fault mode, the third standby chiller shall be automatically started. The two-chiller lead/lag system shall allow manual rotation of the lead chiller, include load balancing if configured, and a staggered restart of the chillers after a power failure.
- G. Electrical Requirements:
- 1. Electrical contractor shall supply and install main electrical power line, disconnect switches, circuit breakers, and electrical protection devices per local code requirements and as indicated necessary by the chiller manufacturer.
 - 2. Electrical contractor shall wire the chilled water pump, condenser water pump, and tower fan control circuit to the chiller control circuit.
 - 3. Electrical contractor shall supply and install electrical wiring and devices required to interface the chiller controls with the building control system if applicable.
 - 4. Electrical power shall be supplied to the unit at the voltage, phase, and frequency listed in the equipment schedule.
- H. Piping Requirements — Instrumentation and Safeties:
- 1. Mechanical contractor shall supply and install pressure gages in readily accessible locations in piping adjacent to the chiller such that they can be easily read from a standing position on the floor. Scale range shall be such that design values shall be indicated at approximately mid-scale.
 - 2. Gages shall be installed in the entering and leaving water lines of the cooler and condenser.
- I. Vibration Isolation:
- Chiller manufacturer shall furnish neoprene isolator pads for mounting equipment on a level concrete surface.
- J. Start-up:
- 1. The chiller manufacturer shall provide a factory-trained representative, employed by the chiller manufacturer, to perform the start-up procedures as outlined in the Start-up, Operation and Maintenance manual provided by the chiller manufacturer.
 - 2. Manufacturer shall supply the following literature:
 - a. Start-up, operation and maintenance instructions.
 - b. Installation instructions.
 - c. Field wiring diagrams.
 - d. One complete set of certified drawings.

K. Special Features:

1. Soleplate Package Accessory:
Unit manufacturer shall furnish a soleplate package consisting of soleplates, jacking screws, leveling pads, and neoprene pads.
2. Spring Isolators Accessory:
Field furnished and selected for the desired degree of isolation.
3. Spare Sensors with Leads Accessory:
Unit manufacturer shall furnish additional temperature sensors and leads.
4. Sound Insulation Kit Accessory (not available on compressor frames 6 and 7):
Unit manufacturer shall furnish a sound insulation kit that covers (select):
 - a. The compressor discharge pipe.
 - b. The compressor housing and motor housing.
 - c. The condenser shell and suction line.Blanket construction shall allow for installation and removal without the use of tape or caulk. Insulation material shall be 11 lb/cu ft fiberglass. Insulation design shall accommodate temperature and pressure probes, gages, tubing, piping, and brackets. An extended 2-in. wide vinyl flap shall cover all exposed seams, thereby minimizing any potential noise leaks. An aluminum nameplate shall be riveted to each blanket piece. Each tag shall be embossed or etched with lettering indicating piece location, description, size, and tag number sequence.
5. Stand-Alone Pumpout Unit Accessory:
A free-standing pumpout shall be provided. The pumpout unit shall use a hermetic reciprocating compressor with water-cooled condenser. Condenser water piping, 3-phase motor power shall be installed at the jobsite by the installing contractor.
6. Separate Storage Tank and Pumpout Unit Accessory:
A free-standing refrigerant storage tank and pumpout unit shall be provided. The storage vessels shall be designed per ASME Section VIII Division 1 code with 185 psig (1276 kPa) design pressure. Double relief valves per ANSI/ASHRAE 15, latest edition, shall be provided. The tank shall include a liquid level gage and pressure gage. The pumpout unit shall use a hermetic reciprocating compressor with water cooled condenser. Condenser water piping and 3-phase motor power shall be installed at the jobsite by the installing contractor.
7. Building Control System Interface (LON) Accessory:
The chiller control system shall have the ability to interface and communicate directly to the building control using a LON-based system. The

- LonWorks Carrier Translator shall output data in standard LON profiles. (19XR compressor frame sizes 2 to 5, E only.)
8. Refrigerant Charge:
The chiller shall ship from the factory fully charged with R-134a refrigerant and oil.
 9. Thermal Insulation:
Unit manufacturer shall insulate the cooler shell, economizer low side compressor suction elbow, motor shell and motor cooling lines. Insulation shall be $\frac{3}{4}$ in. (19 mm) thick with a thermal conductivity not exceeding 0.28 (Btu in.)/hr ft² F [(0.0404 • W)/(m • °C)] and shall conform to UL standard 94, classification 94 HBF.
 10. Automatic Hot Gas Bypass:
Hot gas bypass valve and piping shall be factory furnished to permit chiller operation for extended periods of time.
 11. Cooler and Condenser Tubes:
Contact local Carrier representative for other tube offerings.
 12. Cooler and Condenser Passes:
Unit manufacturer shall provide the cooler and/or condenser with 1, 2 or 3 pass configuration on the water side.
 13. Nozzle-In-Head, 300 psig (2068 kPa):
Unit manufacturer shall furnish nozzle-in-head style waterboxes on the cooler and/or condenser rated at 300 psig (2068 kPa).
 14. Marine Waterboxes, 150 psig (1034 kPa):
Unit manufacturer shall furnish marine style waterboxes on cooler and/or condenser rated at 150 psig (1034 kPa).
 15. Marine Waterboxes, 300 psig (2068 kPa):
Unit manufacturer shall furnish marine style waterboxes on cooler and/or condenser rated at 300 psig (2068 kPa).
 16. Flanged Waterbox Nozzles:
Unit manufacturer shall furnish standard flanged piping connections on the cooler and/or condenser.
 17. Hinges:
Unit manufacturer shall furnish hinges on waterboxes to facilitate tube cleaning.
 18. Pumpout Unit:
A refrigerant pumpout system shall be installed on the chiller. The pumpout system shall include a hermetic compressor and drive, piping, wiring, and motor. (19XR compressor frame sizes 2 to 5, E only.)

19. Optional Compressor Discharge Isolation Valve and Liquid Line Ball Valve:
These items shall be factory installed to allow isolation of the refrigerant charge in the condenser for servicing the compressor.
20. Optional Seismic Isolation Package (Select Models Only):
Package shall meet International Building Code and ASCE 7 seismic qualification requirements in concurrence with ICC ES AC156 Acceptance Criteria for Seismic Qualification by Shake-Table Testing of Nonstructural Components and Systems. Manufacturer shall provide seismic certificate from OSHPD (California only).
21. BACnet Communication Option:
Shall provide factory-installed communication capability with a BACnet network. Allows integration with i-Vu[®] Open control system or a BACnet building automation system. (Integration with i-Vu requires the use of the i-Vu Link module for compressor frames 6 and 7. The UPC Open module is required for compressor frames 2-5, E.)
22. Optional Low-Voltage Unit-Mounted Starter (not available on chiller heat exchanger sizes 8, A, B, C, or D):
An optional reduced voltage wye-delta or solid-state starter shall be supplied. The compressor motor starter shall be factory mounted, wired and tested prior to shipment by the chiller manufacturer. Customer electrical connection for compressor motor power shall be limited to main power leads to the starter, and wiring water pumps and tower fans to the chiller control circuit.
 - a. NEMA 1 enclosure with integral fan cooling and lockable hinged doors.
 - b. Main power disconnect (non-fused type).
 - c. Capability to start and stop chiller, pumps and tower fans.
 - d. 3 kva control/oil heater transformer.
 - e. Branch circuit breaker to provide power for oil pump.
 - f. Branch circuit breaker to provide power for control power and oil heater.
 - g. The following are standard features:
 - 1) Phase loss
 - 2) Phase reversal
 - 3) Phase imbalance
 - 4) 3-phase ground fault
 - 5) Low voltage — phase to phase and phase to ground
 - 6) Medium voltage — phase to ground
 - 7) Current overload
 - 8) Current flow while stopped
 - 9) 3-phase under/over voltage
- 10) 3-phase digital ammeter/voltmeter
- 11) Microprocessor based overload trip protection
- 12) Frequency digital display
- h. Optional unit-mounted solid-state starter shall provide stepless compressor motor acceleration. The starter shall include 6 silicon controlled rectifiers (SCRs) with integrally mounted bypass once the motor has achieved full voltage and speed. The starter shall also display the following:
 - 1) Starter On
 - 2) Run (up to voltage)
 - 3) Phase Correct
 - 4) Over Temperature Fault
 - 5) SCR Gates Energized
 - 6) Ground Fault
 - 7) Current Imbalance Fault
 - 8) Shorted SCR
23. Unit-Mounted Variable Frequency Drive (VFD) with Built-in Harmonic Filter (LiquiFlo™ 2, available for low voltage only):
 - a. Design:
 - 1) VFD shall be refrigerant cooled, microprocessor based, pulse width modulated (PWM) design. Water-cooled designs are not acceptable.
 - 2) Input and output power devices shall be insulated gate bipolar transistors (IGBTs).
 - 3) Active rectifier shall convert incoming voltage / frequency to DC voltage. Input current and voltage shall be regulated.
 - 4) Transistorized inverter and control regulator shall convert DC voltage to a sinusoidal PWM waveform.
 - 5) Integrated chiller controls shall coordinate motor speed and guide vane position to optimize chiller performance over all chiller operating conditions.
 - 6) Surge prevention and surge protection algorithms shall take action to prevent surge and move chiller operation away from surge.
 - b. Enclosure:
 - 1) Pre-painted unit mounted, NEMA 1 cabinet shall include hinged, lockable doors and removable lifting lugs.
 - 2) VFD shall have a short circuit interrupt and withstand rating of at least 65,000 amps (35,000 amps for 575-v units).
 - 3) Provisions to padlock main disconnect handle in the “Off” positions shall be provided. Mechanical interlock to prevent opening cabinet door with disconnect in the “On” position or moving disconnect to the “On” position while the door is open shall be provided.

- 4) Provisions shall be made for top entry of incoming line power cables.
- c. Heat Sink:
 - 1) The heat sink shall be refrigerant cooled. Heat sink and mating flange shall be suitable for ASME design working pressure of 185 psig (1276 kPa).
 - 2) Refrigerant cooling shall be metered by microprocessor control solenoid valve to maintain heat sink temperature within acceptable limits for ambient temperature.
 - 3) Water-cooled heat exchangers requiring cleaning shall not be acceptable.
- d. VFD Rating:
 - 1) Drive shall be suitable for continuous operation at nameplate voltage $\pm 10\%$.
 - 2) Drive shall be suitable for continuous operation at 100% of nameplate amps and 150% of nameplate amps for 5 seconds.
 - 3) Drive shall comply with applicable ANSI, NEMA, UL and NEC standards.
 - 4) Drive shall be suitable for operation in ambient temperatures between 40 and 104 F (4.4 and 40 C), 95% humidity (non-condensing) for altitudes up to 6000 ft (1829 m) above sea level. Specific drive performance at jobsite ambient temperature and elevation shall be provided by the manufacturer in the bid.
- e. User Interface:

A single display shall provide interface for programming and display of VFD and chiller parameters. Viewable parameters include:

 - 1) Operating, configuration and fault messages
 - 2) Frequency in Hz
 - 3) Load and line side voltage and current (at the VFD)
 - 4) kW (line and load side)
 - 5) IGBT temperatures
- f. VFD Performance:
 - 1) VFD voltage total harmonic distortion (THD) and harmonic current total demand distortion (TDD) shall not exceed IEEE-519 requirements using the VFD circuit breaker input terminals as the point of common coupling (PCC).
 - 2) VFD full load efficiency shall meet or exceed 97% at 100% VFD rated ampacity.
 - 3) Active rectifier shall regulate unity displacement power factor to 0.99 or higher at full load.
 - 4) Voltage boost capability to provide full motor voltage at reduced line voltage conditions.
 - 5) Soft start, linear acceleration, coast to stop.
 - 6) Base motor frequency shall be either 50 or 60 Hz. Adjustable frequency range from 39 to 60 Hz or 32.5 to 50 Hz.
- g. VFD Electrical Service (single point power):
 - 1) VFD shall have input circuit breaker with minimum 65,000 amp interrupt capacity.
 - 2) VFD shall have standard 15 amp branch circuit breaker to provide power for chiller oil pump.
 - 3) VFD shall have standard 3 kva control power transformer with circuit breaker provides power for oil heater, VFD controls and chiller controls.
 - 4) The branch oil pump circuit breaker and control power transformer shall be factory wired.
 - 5) Nameplate voltage shall range between 380 and 460 $\pm 10\%$, 3 phase, 50/60 Hz $\pm 2\%$ Hz.
- h. Discrete Outputs:

115 v discrete contact outputs shall be provided for field wired:

 - 1) Chilled water pump
 - 2) Condenser water pump
 - 3) Alarm status
 - 4) Tower fan low
 - 5) Tower fan high
- i. Analog Output:

An analog (4 to 20 mA) output for head pressure reference shall be provided. This signal shall be suitable to control a 2-way or 3-way water regulating valve in the condenser piping.
- j. Protection (the following shall be supplied):
 - 1) Under-voltage
 - 2) Over voltage
 - 3) Phase loss
 - 4) Phase reversal
 - 5) Ground fault
 - 6) Phase unbalance protection
 - 7) Single cycle voltage loss protection
 - 8) Programmable auto re-start after loss of power
 - 9) Motor overload protection (NEMA Class 10)
- k. VFD Testing:

VFD shall be factory mounted, wired and tested on the chiller prior to shipment.
24. Unit-Mounted Variable Frequency Drive (VFD) without Built-In Harmonic Filter (available for low voltage only):
 - a. Design:
 - 1) VFD shall be refrigerant cooled, micro-processor based, pulse width modulated

- (PWM) design. Water cooled designs are not acceptable.
- 2) Output power devices shall be insulated gate bipolar transistors (IGBTs).
 - 3) Converter section with full-wave fixed diode bridge rectifier shall convert incoming fixed voltage/frequency to fixed DC voltage.
 - 4) DC link shall filter and smooth the converted DC voltage.
 - 5) Transistorized inverter and control regulator shall convert fixed DC voltage to a sinusoidal PWM waveform.
 - 6) Integrated controls shall coordinate motor speed and guide vane position to optimize chiller performance over a wide variety of operating conditions.
 - 7) Surge prevention and surge protection algorithms shall take action to prevent surge and move chiller operation away from surge.
- b. Enclosure:
- 1) Pre-painted, unit mounted NEMA 1 cabinet shall include hinged, lockable doors and removable lifting lugs.
 - 2) VFD shall have a short circuit interrupt and withstand rating of at least 100,000 amps.
 - 3) Provisions to padlock main disconnect handle in the "Off" positions shall be provided. Mechanical interlock to prevent opening cabinet door with disconnect in the "On" position or moving disconnect to the "ON" position while the door is open shall be provided.
 - 4) Provisions shall be made for top entry of incoming line power cables.
- c. Heat Sink:
- 1) The heat sink shall be refrigerant cooled. Heat sink and mating flanges shall be suitable for ASME design working pressure of 185 psig (1276 kPa).
 - 2) Refrigerant cooling shall be metered by integrated standard controls to maintain heat sink temperature within acceptable limits for ambient temperature.
- d. VFD Rating:
- 1) Drive shall be suitable for nameplate voltage $\pm 10\%$.
 - 2) Drive shall be suitable for continuous operation at 100% of nameplate amps and 150% of nameplate amps for 3 seconds.
 - 3) Drive shall comply with applicable UL, CE, and NEMA standards.
 - 4) Drive shall be suitable for operation in ambient temperatures between 40 and 104 F (4.4 and 40 C), 95% humidity (non-condensing) for altitudes up to 3300 ft (1006 m) above sea level.
- Specific drive performance at jobsite ambient temperature and elevation shall be provided by the manufacturer in the bid.
- e. User Interface:
- Displays shall provide interface for programming and display of VFD and chiller parameters. Viewable parameters include:
- 1) Operating, configuration and fault messages
 - 2) Frequency in hertz
 - 3) Load and line side voltage and current (at the VFD)
 - 4) kW (on the VFD interface)
- f. VFD Performance:
- 1) VFD full load efficiency shall meet or exceed 97% at 100% VFD Rated ampacity.
 - 2) Displacement Input Power Factor shall meet or exceed 95% soft start, linear acceleration, coast to stop.
 - 3) Base motor frequency shall be either 50 or 60 Hz. Adjustable frequency range from 38 to 60 Hz or 32.5 to 50 Hz.
- g. VFD Electrical Service (single point power):
- 1) VFD shall have input circuit breaker with minimum 100,000 amp interrupt capacity.
 - 2) VFD shall have standard 15 amp branch oil pump circuit breaker to provide power for chiller oil pump.
 - 3) VFD shall have standard 3 kva control power transformer with circuit breaker provides power for oil heater, VFD controls and chiller controls.
 - 4) The branch oil pump circuit breaker and control power transformer shall be factory wired.
 - 5) Input power shall be 380/480 vac, ± 10 percent, 3 phase, 50/60 Hz, ± 3 Hz.
- h. Discrete Outputs:
- 115-v discrete contact outputs shall be provided for:
- 1) Circuit breaker shunt trip
 - 2) Chilled water pump
 - 3) Condenser water pump
 - 4) Alarm status.
- i. Analog Output:
- An analog (4 to 20 mA) output for head pressure reference shall be provided. This signal shall be suitable to control a 2-way or 3-way water regulating valve in the condenser piping.
- j. Protection (the following shall be supplied):
- 1) Under-voltage
 - 2) Over voltage
 - 3) Phase loss
 - 4) Phase reversal

Guide specifications (cont)



- 5) Ground fault
- 6) Phase unbalance protection
- 7) Single cycle voltage loss protection
- 8) Programmable auto re-start after loss of power
- 9) Motor overload protection (NEMA Class 10)
- 10) Motor over temperature protection

k. VFD Testing:

VFD shall be factory mounted, wired and tested on the chiller prior to shipment.

25. Free-Standing Medium Voltage Variable Frequency Drive:

a. VFD Design:

- 1) Technology shall allow connection of the drive to utility power without the requirement of an isolation transformer.
- 2) Direct-to-drive technology shall have active front end to track and regulate input current to maintain sine wave current draw.
- 3) VFD shall be microprocessor-based, pulse width modulated (PWM) design.
- 4) Input and output power devices shall be 6500 volt rated symmetrical gate commutated thyristor (SGCT) to achieve superior PWM switching pattern and and significantly reduce line current harmonics.
- 5) Low voltage and medium voltage compartments shall be totally isolated and separated.
- 6) Power shall be isolated by means of a vacuum starter that can be locked out/tagged out. This starter can be integral to drive for "A" frames, part of line up or located outside of line up for "B" frames.
- 7) Integrated controls shall coordinate motor speed and guide vane position to optimize chiller performance over a wide variety of operating conditions.
- 8) Surge prevention and surge protection algorithms shall take action to prevent surge and move chiller operation away from surge.

b. Enclosure:

- 1) Rear access shall not be required and VFD shall be fully accessible from front.
- 2) Pre-painted cabinet (NEMA 1) includes hinged, lockable doors and removable lifting lugs.
- 3) Enclosure shall have short circuit interrupt and withstand rating of at least 25,000 amps.

c. Heat Sink:

- 1) The heat sink shall be air-cooled from 200 hp to 5500 hp.
- 2) Advanced overtemperature compensation algorithm shall provide standard

heat sink temperature and flow monitoring.

d. VFD Rating:

- 1) Drives less than 6600 vac shall be suitable for nameplate voltage plus or minus 10%; 6600-vac drives shall have voltage rating of plus 5% and minus 10%.
- 2) Drive shall be suitable for continuous operation at 100% of nameplate amps and 110% of nameplate amps for 60 seconds every ten minutes; voltage sag of -30%; and control power loss ride through of 5 cycles standard and >5 cycles with optional UPS (uninterruptible power supply).
- 3) Drive complies with applicable sections of NEMA, UL, and NEC standards and is UL, Canada listed.
- 4) Drive shall be suitable for operation in ambient temperatures between 40 and 104 F (4.4 and 40 C), 95% humidity (non-condensing) for altitudes up to 3300 ft (1006 m) above sea level. Specific drive performance at jobsite ambient temperature and elevation shall be provided by the manufacturer in the bid.

e. VFD Performance:

- 1) VFD voltage total harmonic distortion (THD) shall not exceed 3% and harmonic current total demand distortion (TDD) shall not exceed IEEE-519 requirements using the VFD circuit breaker input terminals as the point of common coupling (PCC).
- 2) VFD full load efficiency shall meet or exceed 97% at 100% VFD rated ampacity.
- 3) Displacement input power factor shall meet or exceed 99% to unity gain at full load.
- 4) Soft start, linear acceleration, coast to stop.
- 5) Base motor frequency shall be either 50 or 60 Hz, adjustable frequency range from 39 to 60 Hz or 32.5 to 50 Hz.

f. VFD Electrical Service (Single Point Power):

VFD shall have input circuit breaker with minimum 25,000 amp interrupt capacity.

g. Protection (the following shall be supplied):

- 1) Under voltage
- 2) Over voltage
- 3) Phase loss
- 4) Phase reversal
- 5) Ground fault
- 6) Phase unbalance protection
- 7) Single cycle voltage loss protection
- 8) Programmable auto restart after loss of power

- 9) Motor overload protection (NEMA Class 10)
- 10) Motor over temperature protection
- h. Testing:

Drive shall be 100% load tested from VFD manufacturer's factory and shipped without any unwiring or electrical components disassembled inside main VFD cabinet.
- 26. Free-Standing Low Voltage Variable Frequency Drive:
 - a. Design:
 - 1) Output power devices shall be insulated gate bipolar transistors (IGBTs).
 - 2) Converter section with full wave fixed diode bridge rectifier shall convert incoming fixed voltage/frequency to fixed DC voltage.
 - 3) Transistorized inverter and control regulator shall convert fixed DC voltage to a sinusoidal PWM waveform.
 - 4) VFD shall have 1.5% AC line reactor.
 - b. Enclosure:

Main section and control section shall be housed in connected NEMA 1 cabinets.
 - c. User Interface:

Door-mounted digital keypad with non-volatile memory shall have 6 line, 30 character back-lit LCD display for programming and display of VFD parameters. Viewable parameters include:

 - 1) Operating, configuration and fault messages
 - 2) Frequency in Hz
 - 3) Manual or automatic control mode
 - 4) Output frequency
 - 5) Percent output voltage, or voltage
 - 6) Percent output current, or current
 - 7) kW and kWh
 - d. VFD Electrical Service:
 - 1) VFD shall have main standard interrupting capacity circuit breaker with shunt trip (65 kAIC interrupt capacity).
 - 2) VFD shall have oil pump circuit breaker (65 kAIC interrupt capacity).
 - 3) VFD shall have pumpout unit circuit breaker (65 kAIC interrupt capacity).
 - 4) 110-v power shall be provided for ISM (integrated starter module) board.
 - e. Analog Output:

An analog (4 to 20 mA) output for head pressure reference shall be provided.

