

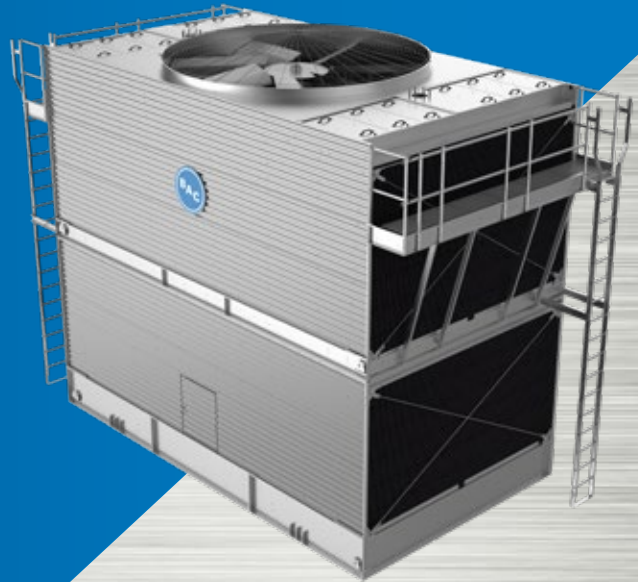

Series 3000 Cooling Tower



Trusted Reliability and Highest Efficiency



For the most up to date information,
visit www.BaltimoreAircoil.com/3000

C6 OVERVIEW

C8 BENEFITS

C10 DESIGN DETAILS

C12 FEATURES & OPTIONS

C15 ENGINEERING DATA

C26 STRUCTURAL SUPPORT

Series 3000 Cooling Tower



Trusted Reliability and Highest Efficiency

The Series 3000 Cooling Tower leads the industry with the highest efficiency lowest operating cost, maintenance and installation, greatest layout flexibility, resulting in trusted reliability.

171 - 1,446 tons

Up to 4,500 USGPM^[1]

Crossflow // Axial Fan // Induced Draft

TriArmor[®]
CORROSION PROTECTION SYSTEM

EVERTOUGH[™]
CONSTRUCTION

ENDURADRIVE[®]
Fan System

XE Models



Series 3000 Benefits

Lowest Energy Usage

UP TO 40% MORE ENERGY EFFICIENT WITH XE MODELS^[1]

- Extremely efficient XE Models are at least two times more energy efficient than the minimum requirements established in ASHRAE Standard 90.1
- XE models help to contribute to Energy and Atmosphere LEED® Credits (EAc1)
- Average payback of less than two years with BAC's enhanced selections which include user-defined life-cycle cost inputs based on energy savings and minimum payback

Lowest Maintenance Costs

FASTEST ACCESS TO KEY COMPONENTS

- Easiest access to the cold water basin, hot water basin, and the drive system with the crossflow design, large access doors, and an optional internal walkway
- Fast inspection of the spray water distribution system while the unit is in operation
- Virtually eliminate maintenance with the optional ENDURADRIVE® Fan System

Easiest Installation

PRE-ASSEMBLED PLATFORMS AND LADDERS

- Reduce on-site labor requirements and ensure on-time commissioning with factory pre-assembled external platform and ladder options
- Ensure proper fit for any application with flexible inlet/outlet piping connection locations
- For field assembly, knockdown units are available
- Optional basinless construction is ideal for installations that use a common sump for multiple tower cell

Increased Layout Flexibility

MINIMIZE FOOTPRINT

- For large projects, minimize space needed by fitting multiple units together
- Installations can be easily expanded with additional cooling tower cells
- Variety of options to meet layout requirements, including a range of structural steel spacings and a velocity recovery stack for additional cooling

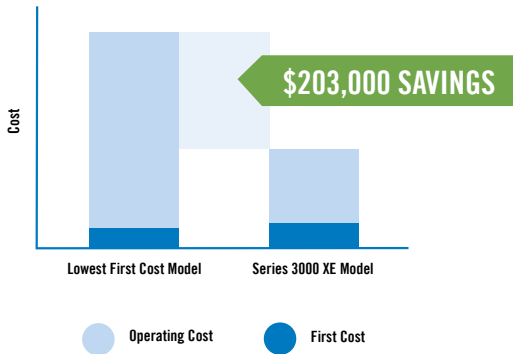

Note: Operating costs based on fan kW x \$0.12/kWh x 2500EFLH (equivalent full load hours) x 20 years (2011 ASHRAE Handbook HVAC Applications) x 3% per year energy inflation factor.

Operating Cost Comparison

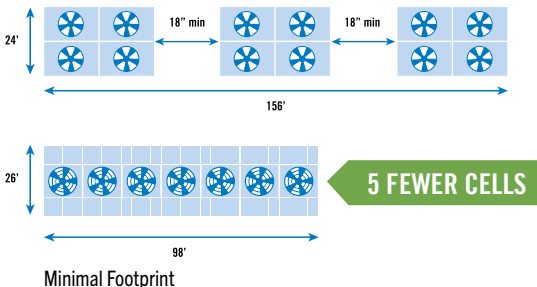

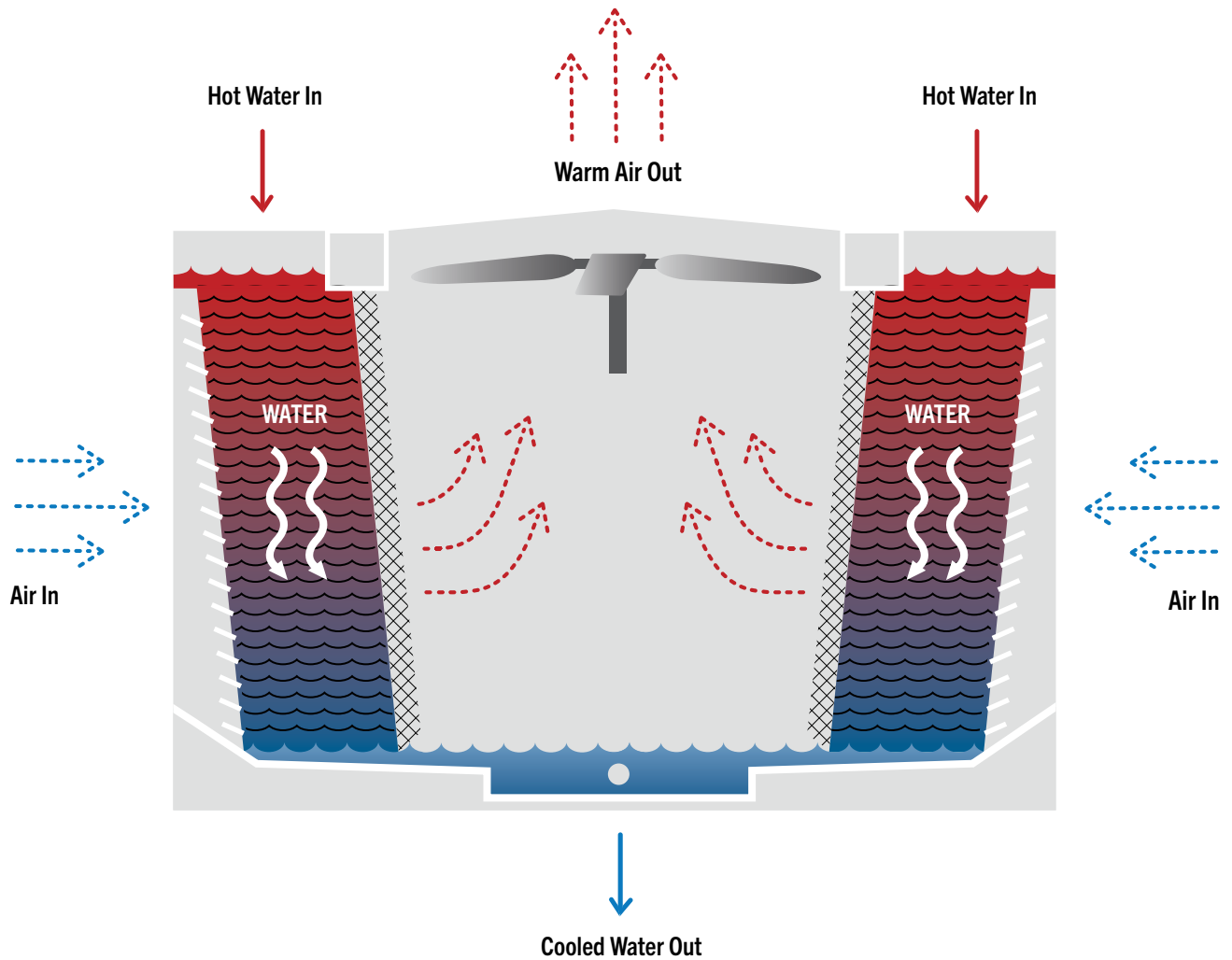

Series 3000 Cooling Tower Principle of Operation



NOTE:

1. Compared to standard cooling towers.

Series 3000 Design Details

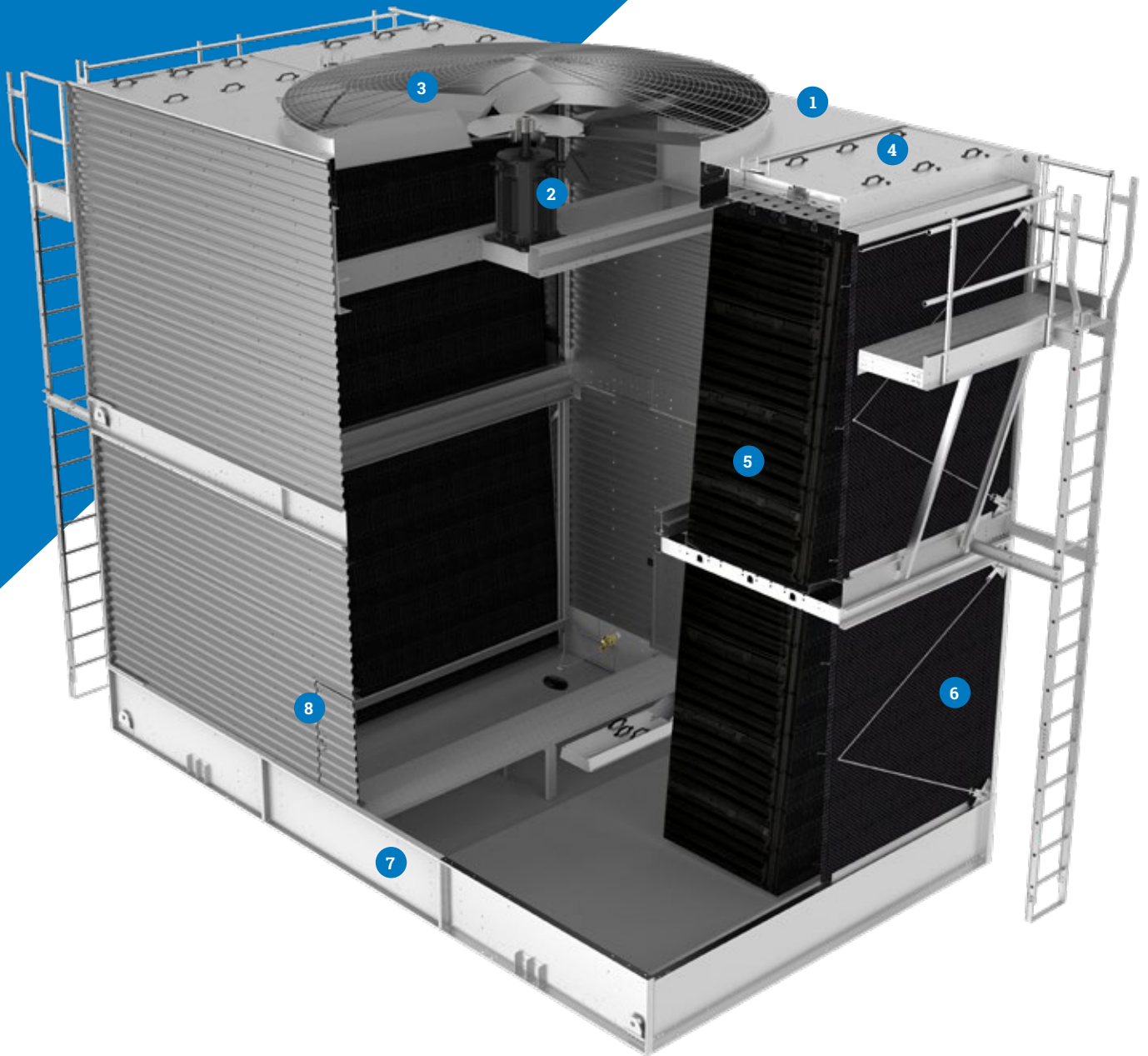

1 Heavy-Duty Construction

- G-235 mill galvanized steel frame
- FRP casing panels are corrosion resistant, ensuring long life
- Meets seismic and wind requirements for International Building Code, FM and HCAI approval

2 BALTIDRIVE® Power Train

(The optional ENDURADRIVE® Fan System is shown)

- Premium quality, solid-backed, multi-groove belt
- Corrosion resistant materials of construction
- Heavy-duty bearings L₁₀ 80,000 hours
- Premium efficient/inverter duty-ready motors are standard
- Extended lubrication lines with grease fittings are standard
- 7-year motor warranty⁽¹⁾; 5-year warranty on drive components

3 Low HP Axial Fan(s)

- Quiet operation
- High efficiency
- Corrosion resistant aluminum

4 Water Distribution System

- Steel covers in easy to remove sections reduce maintenance
- Low pump head gravity distribution basins reduces system pump energy
- Visible and accessible during operation
- Large orifice, non-clog nozzles
- Standard weir dams can accommodate a flow range of 50% to 100%

5 BACross® Fill with Integral Drift Eliminators

- High efficiency heat transfer surface
- Recyclable polyvinyl chloride (PVC)
- Impervious to rot, decay, and biological attack
- Flame spread rating of 5 per ASTM E84

6 Combined Inlet Shields

- Corrosion and UV resistant
- Less sunlight and debris enters the cold water basin; deters algae growth and reduces cleaning requirements

7 Cold Water Basin

- Sloped cold basin for easy cleaning
- Suction strainer with anti-vortex hood can be removed with the flip of a single latch for easy cleaning and maintenance

8 Hinged Access Doors

- Inward hinged door on each end wall allows easy access to the interior of the unit



NOTE:

1. Motors are warranted for 7 years from date of shipment when space heaters are field-wired at time of initial installation.

Series 3000 Features & Options

171 - 1,446 tons^[1] // Up to 4,500 USGPM^[1] // Crossflow // Axial Fan // Induced Draft

Features & Options	Page	Description
MATERIALS OF CONSTRUCTION		
G-235 Galvanized Steel	H3	Universally recognized for its strength and durability
TriArmor® Corrosion Protection System	H3	The ultimate in corrosion and leak protection for the basin at the best value; 10-year leak & corrosion warranty
EVERTOUGH™ Construction	H4	Combines the most corrosion resistant materials at the best value for most water chemistries including TriArmor® Corrosion Protection (cold water basin), Baltibond® Hybrid Coating (structure), stainless steel (submerged components in the cold water basin) fiberglass reinforced polymer (casing panels and louvers), and pultruded fiberglass reinforced polymer (hot water basins).
Baltibond® Hybrid Coating	H4	Thermosetting hybrid polymer coating baked onto the G-235 galvanized steel creating another layer of protection
Welded Stainless Steel Cold Water Basin	H4	All steel panels and structural members of the basin are Type 304 stainless steel for increased corrosion resistance or job requirement
Stainless Steel Hot Water Basin	H5	The hot water basins and basin covers are constructed of Type 304 stainless steel
JE Premier Series® Construction	H6	All unit steel panels, structural elements, and the welded basin are Type 304 stainless steel for increased corrosion resistance or job requirement, 5 year leak proof warranty
Basinless Unit Construction	H6	Enables units to be directly installed on new or existing cold water basins; simplifies piping and pumping for multi cells, provides the most cost effective option to replace field-erected equipment
Fiberglass Reinforced Polymer (FRP) Casing Panels	H6	Used with BAC's durable frame construction, FRP casing panels offer a more durable corrosion resistant unit
Steel Casing Panels and Louvers	H6	Available in G-235 mill galvanized steel, Baltibond® Hybrid Coating, and stainless steel
DRIVE SYSTEM^[2]		
Baltidrive® Power Train	H12	Belt driven system with a multigroove and cast aluminum sheaves; reliable and easy to maintain
ENDURADRIVE® Fan System ^[3]	H12	Direct-drive fan system offers the highest reliability, lowest maintenance and energy costs giving you total peace of mind; 7 year motor warranty
Extended Lubrication Lines	H13	Easy lubrication of the fan shaft bearings from inside the access door
Baltiguard™ Fan System	H14	Two motors per fan; one motor for full speed and load, the other is a pony motor with 2/3 capacity
Gear Drive System, Close-Coupled Motor	H14	A nickel-alloy steel shaft, casehardened gears, self lubrication, and a single piece, gray cast iron; gear drive and couplings selected with a 2.0 service factor
Gear Drive System, Externally Mounted Motor	H15	A non-corrosive carbon-fiber composite drive shaft with stainless steel hubs is selected with a 2.0 service factor
Vibration Cutout Switch	H16	Protects against rotating equipment failure
COLD WATER BASIN		
Mechanical Water Level Control	H17	Maintains the water level in the basin with a float valve
Electric Water Level Control	H17	Maintains the water level with a conductivity actuator and a solenoid valve
Low and High Level Alarm Float Switches	H17	Alerts operators to abnormal conditions to ensure the highest system reliability
Side Outlet Depressed Sump Box	H17	Available for field installation below the base of the tower; facilitates horizontal piping below the basin, and is a compact alternative to using an elbow in the piping arrangement, saving on both installation time and cost
Steam Coil/Steam Injector Basin Freeze Protection	H18	Available to provide basin freeze protection
Basin Sweeper Piping	H18	Complete basin piping system with nozzles; easily connect side stream filtration equipment by others
Basin Heaters	H18	Protect the basin water from freeze-up in below freezing ambient conditions
MULTI CELL UNIT		
Flume Box ^[4]	H21	Balances the water level in the cold water basins of multi cell units
Equalizer	H21	Equalizer connections are available for multi cell cooling towers in lieu of a flume box; allows for easy isolation of a cell while continuing system operation for winter operation, maintenance, or inspection

Features & Options	Page	Description
WATER DISTRIBUTION SYSTEM		
Easy to Inspect Water Distribution System	—	Inspect the water distribution system while the unit is operating
Top Inlet Connections	—	Top inlet connections to each of the hot water basins
Weir Dams	H23	Weir dams are used to successfully modulate the water flow; the hot water basin can accommodate a flow range of 50% to 100% of the design flow
EASY CONNECT® Piping Arrangement	H24	Simplifies water inlet piping by automatically balancing the flow within each cell, eliminating the need for flow balancing valve
FILL		
Fill	H26	PVC fill for applications with entering water temperatures up to 130°F (54.4°C)
High Temperature Fill	H26	HPVC fill for applications with entering water temperatures up to 140°F (60°C)
SHIPPING AND RIGGING		
Rigging Guides	H29	Allow easy alignment and engagement of top and bottom sections, especially critical during multi cell installations
Knockdown Units	H29	The unit ships disassembled for jobs where there are crane or other site limitations
FANS AND SOUND		
Axial Fan	H31	The axial fan optimizes low sound levels and maximizes thermal performance
Low Sound Fan	H31	Reduces sound up to 9 dBA
Whisper Quiet Fan	H31	Reduces sound up to 19 dBA
Sound Attenuation	H31	Available for the air intake and discharge to further reduce sound levels
AIR INTAKE		
Louvers	H33	Specifically designed with greater spacing between louvers (12") and are completely separate from the fill section, reducing scale and ice accumulation and allowing for unobstructed air flow through the unit
Combined Inlet Shields	H33	Constructed from corrosion and UV resistant PVC, bent flow path blocks sunlight from the cold water basin and fill section and acts as a screen to prevent debris from entering the unit
Air Intake Screens	H33	1" x 1" wire mesh screens factory-installed over the air intake louvers to prevent debris from entering the unit
AIR DISCHARGE		
Fan Cowl Extensions	H35	Elevate the air discharge to the top of parapet walls for maximum thermal capacity
Velocity Recovery (VR) Stacks	H35	A conical fan cowl extension that reduces the discharge air pressure, moving more air for higher added thermal capacity
ACCESS		
Large Plenum Area for Access	—	Two large hinged access doors are connected by an elevated walkway, provides access to the collection basin and drive system
Motor Removal System	H38	Includes motor removal davit arm(s) to facilitate motor replacement
External Platforms and Ladder Packages	H38	Factory preassembled and pre-fitted, attaches quickly in the field; easily inspect the spray distribution system while the unit is in operation
Access Door Platform and Ladder Packages	H39	Easily access the unit when installed on elevated supports
Handrail and Ladder Packages	H39	Provide safe access to the top of the unit for maintenance to the distribution system
Internal Walkway	H40	Allows easy access to the plenum area of the basin, make-up, fill, and drive system
Internal Service Platform and Ladder Packages	H40	Easily access the motor and drive assemblies; available on two piece units

NOTES:

- Nominal tons of cooling represents the capability to cool 3 USGPM of water from a 95°F entering water temperature to an 85°F leaving water temperature at a 78°F entering wet-bulb temperature.
- ENDURADRIIVE® Fan System is standard on S2E-1424-14U and S3E-1424-14W but optional on other models.
- Motors are warranted for 7 years from date of shipment when space heaters are field-wired at time of initial installation.
- Flume boxes are standard on all multi cell units.



Series 3000 Engineering Data

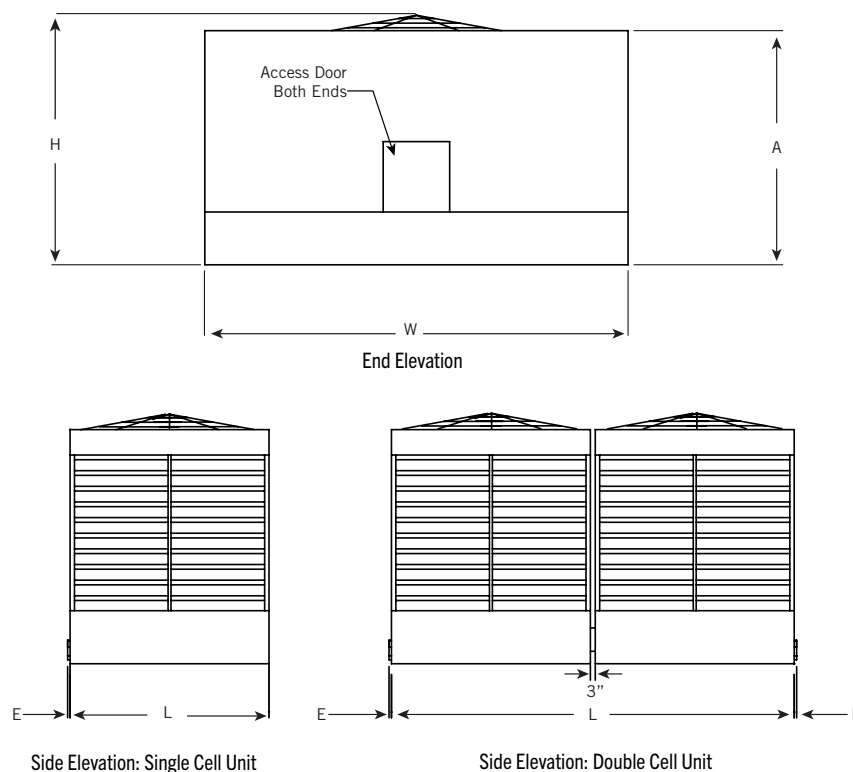

NOTES:

1. The E dimension represents the distance between the outer edge of the unit and the connection. For 8.5', 10', and 12' wide units this dimension is 1-1/8". The 14' wide units the E dimension is 1/2".
2. The following units ship in two sections per cell. The top section is the heaviest and tallest. Top section heights are:

S3E Model	Catalog Upper Section With Installed Fan Guard Height (in)	S3E Model	Catalog Upper Section With Installed Fan Guard Height (in)
S3E-1222-10x	10'-3"	S3E-1424-13 (L to Q)	10'-5"
S3E-1222-12x	10'-3"	S3E-1424-13 (R to S)	10'-11"
S3E-1222-13x	10'-3"	S3E-1424-13 (T)	11'-3"
S3E-1222-14x	11'-7"	S3E-1424-14 (M to Q)	11'-9"
S3E-1424-12 (L to Q)	10'-5"	S3E-1424-14 (R to S)	10'-11"
S3E-1424-12 (R to S)	10'-11"	S3E-1424-14 (T to W)	12'-7"
S3E-1424-12 (T)	11'-3"		

Do not use for construction. Refer to factory certified dimensions. This catalog includes data current at the time of publication, which should be reconfirmed at the time of purchase. Up-to-date engineering data, free product selection software, and more can be found at BaltimoreAircoil.com.

Series 3000 Single Cell Data

Model Number	Nominal Tonnage ⁽³⁾	Motor HP	Fan (CFM)	Weights (lbs)			Dimensions ⁽⁵⁾			
				Operating ⁽⁴⁾	Shipping	Heaviest Section	L	W	H ⁽⁶⁾	A
S3E-8518-05L	293	15	77,410	15,170	8,030	8,030	8'-6"	18'-1"	9'-10"	8'-8"
S3E-8518-05M	322	20	84,620	15,230	8,090	8,090	8'-6"	18'-1"	9'-10"	8'-8"
S3E-8518-06L	329	15	84,170	16,030	8,360	8,360	8'-6"	18'-1"	11'-2"	10'-0"
S3E-8518-06M	361	20	91,930	16,050	8,380	8,380	8'-6"	18'-1"	11'-2"	10'-0"
S3E-8518-06N	388	25	98,420	16,080	8,410	8,410	8'-6"	18'-1"	11'-2"	10'-0"
S3E-8518-06O	406	30	104,060	16,130	8,460	8,460	8'-6"	18'-1"	11'-2"	10'-0"
S3E-8518-07M	400	20	98,970	18,330	8,760	8,760	8'-6"	18'-1"	12'-6"	11'-4"
S3E-8518-07N	429	25	105,860	18,360	8,790	8,790	8'-6"	18'-1"	12'-6"	11'-4"
S3E-8518-07O	451	30	111,830	18,410	8,840	8,840	8'-6"	18'-1"	12'-6"	11'-4"
S3E-8518-07P	484	40	121,940	18,570	9,000	9,000	8'-6"	18'-1"	12'-6"	11'-4"
S3E-1020-06M	384	20	97,900	19,140	9,540	9,540	9'-10"	20'-1"	10'-10"	10'-0"
S3E-1020-06N	412	25	104,760	19,280	9,680	9,680	9'-10"	20'-1"	10'-10"	10'-0"
S3E-1020-06O	436	30	110,730	19,330	9,730	9,730	9'-10"	20'-1"	10'-10"	10'-0"
S3E-1020-07M	425	20	105,810	20,180	9,890	9,890	9'-10"	20'-1"	12'-2"	11'-4"
S3E-1020-07N	457	25	113,200	20,320	10,030	10,030	9'-10"	20'-1"	12'-2"	11'-4"
S3E-1020-07O	484	30	119,610	20,370	10,080	10,080	9'-10"	20'-1"	12'-2"	11'-4"
S3E-1020-07P	530	40	130,440	20,530	10,240	10,240	9'-10"	20'-1"	12'-2"	11'-4"
S3E-1222-06M	438	20	112,310	23,660	11,380	11,380	11'-10"	21'-7"	10'-11"	10'-0"
S3E-1222-06N	471	25	120,200	23,800	11,520	11,520	11'-10"	21'-7"	10'-11"	10'-0"
S3E-1222-06O	500	30	127,050	23,850	11,570	11,570	11'-10"	21'-7"	10'-11"	10'-0"
S3E-1222-07N	523	25	130,040	25,150	12,120	12,120	11'-10"	21'-7"	12'-3"	11'-4"
S3E-1222-07O	554	30	137,410	25,200	12,170	12,170	11'-10"	21'-7"	12'-3"	11'-4"
S3E-1222-07P	607	40	149,860	25,360	12,330	12,330	11'-10"	21'-7"	12'-3"	11'-4"
S3E-1222-07Q	652	50	160,280	25,370	12,340	12,340	11'-10"	21'-7"	12'-3"	11'-4"
S3E-1222-07R	690	60	169,320	26,130	13,100	13,100	11'-10"	21'-7"	12'-9"	11'-4"
S3E-1222-10P	757	40	180,450	33,510	15,330	9,010	11'-10"	21'-7"	16'-5"	15'-6"
S3E-1222-10Q	810	50	192,540	33,670	15,490	9,170	11'-10"	21'-7"	16'-5"	15'-6"
S3E-1222-10R	856	60	203,010	33,680	15,500	9,180	11'-10"	21'-7"	16'-5"	15'-6"
S3E-1222-10S	916	75	216,630	34,640	16,460	10,140	11'-10"	21'-7"	16'-5"	15'-6"
S3E-1222-12P	812	40	191,550	36,250	16,260	9,120	11'-10"	21'-7"	19'-1"	18'-2"
S3E-1222-12Q	869	50	204,250	36,310	16,320	9,180	11'-10"	21'-7"	19'-1"	18'-2"
S3E-1222-12R	917	60	215,250	36,520	16,530	9,390	11'-10"	21'-7"	19'-1"	18'-2"
S3E-1222-12S	981	75	229,520	37,480	17,490	10,350	11'-10"	21'-7"	19'-1"	18'-2"
S3E-1222-13P	839	40	196,980	37,170	16,720	9,120	11'-10"	21'-7"	20'-5"	19'-6"
S3E-1222-13Q	897	50	209,990	37,230	16,780	9,180	11'-10"	21'-7"	20'-5"	19'-6"
S3E-1222-13R	947	60	221,240	37,440	16,990	9,390	11'-10"	21'-7"	20'-5"	19'-6"
S3E-1222-13S	1,013	75	235,850	37,520	17,070	9,470	11'-10"	21'-7"	20'-5"	19'-6"

Model Number	Nominal Tonnage ⁽³⁾	Motor HP	Fan (CFM)	Weights (lbs)			Dimensions ⁽⁵⁾			
				Operating ⁽⁴⁾	Shipping	Heaviest Section	L	W	H ⁽⁶⁾	A
S3E-1222-14P	872	40	203,930	37,590	17,150	9,600	11'-10"	21'-7"	21'-9"	20'-10"
S3E-1222-14Q	933	50	217,360	37,650	17,210	9,660	11'-10"	21'-7"	21'-9"	20'-10"
S3E-1222-14R	985	60	228,970	37,810	17,370	9,820	11'-10"	21'-7"	21'-9"	20'-10"
S3E-1222-14S	1,056	75	244,030	37,890	17,450	9,900	11'-10"	21'-7"	21'-9"	20'-10"
S3E-1222-14T ⁽¹⁾	1,147	100	265,000	39,810	19,370	10,990	11'-10"	21'-7"	21'-9"	20'-10"
S3E-1424-07O	621	30	154,290	34,500	16,460	16,460	14'-0"	24'-1"	12'-4"	11'-4"
S3E-1424-07P	680	40	168,280	34,660	16,620	16,620	14'-0"	24'-1"	12'-4"	11'-4"
S3E-1424-07Q	729	50	179,930	34,670	16,630	16,630	14'-0"	24'-1"	12'-4"	11'-4"
S3E-1424-07R	772	60	189,980	34,680	16,640	16,640	14'-0"	24'-1"	12'-4"	11'-4"
S3E-1424-12Q	995	50	234,340	44,480	21,640	11,900	14'-0"	24'-1"	19'-3"	18'-2"
S3E-1424-12R	1,050	60	246,760	44,640	21,800	12,060	14'-0"	24'-1"	19'-9"	18'-2"
S3E-1424-12S	1,121	75	262,860	44,690	21,850	12,110	14'-0"	24'-1"	19'-9"	18'-2"
S3E-1424-12T ⁽¹⁾	1,207	100	279,550	46,610	23,770	13,200	14'-0"	24'-1"	20'-1"	18'-2"
S3E-1424-13Q	1,031	50	241,640	45,860	22,030	11,900	14'-0"	24'-1"	20'-7"	19'-6"
S3E-1424-13R	1,088	60	254,360	46,020	22,190	12,060	14'-0"	24'-1"	21'-1"	19'-6"
S3E-1424-13S	1,161	75	270,860	46,070	22,240	12,110	14'-0"	24'-1"	21'-1"	19'-6"
S3E-1424-13T ⁽¹⁾	1,250	100	287,930	47,990	24,160	13,200	14'-0"	24'-1"	21'-5"	19'-6"
S3E-1424-14Q	1,075	50	250,810	47,440	22,420	12,650	14'-0"	24'-1"	21'-11"	20'-10"
S3E-1424-14R	1,134	60	263,950	47,600	22,580	12,810	14'-0"	24'-1"	22'-5"	20'-10"
S3E-1424-14S	1,215	75	280,990	47,650	22,630	12,860	14'-0"	24'-1"	22'-5"	20'-10"
S3E-1424-14T ⁽¹⁾	1,303	100	300,200	49,570	24,550	13,950	14'-0"	24'-1"	22'-9"	20'-10"
S3E-1424-14U ⁽²⁾	1,374	119	316,630	50,280	25,260	14,660	14'-0"	24'-1"	22'-5"	20'-10"
S3E-1424-14W ⁽²⁾	1,394	125	321,160	50,280	25,260	14,660	14'-0"	24'-1"	22'-5"	20'-10"



NOTES FOR SINGLE CELL UNITS:

- S3E-1222-14T, S3E-1424-12T, S3E-1424-13T and S3E-1424-14T are supplied with a gear drive system as standard.
- S3E-1424-14U and S3E-1424-14W are supplied with the ENDURADRIVE® Fan System as standard.
- Nominal tons of cooling represents the capability to cool 3 USGPM of water from a 95°F entering water temperature to an 85°F leaving water temperature at a 78°F entering wet-bulb temperature.
- Operating weight is based on the water level in the cold water basin at overflow height. If a lower operating weight is needed to meet design requirements, your local BAC Representative can provide additional assistance.
- Refer to **page C15** for dimensional reference drawings.
- Models shipped with an optional gear drive or Low Sound Fan may have heights up to 10.5" greater than shown. For units with Whisper Quiet Fans please contact your local BAC Representative for accurate height dimensions.

Do not use for construction. Refer to factory certified dimensions. This catalog includes data current at the time of publication, which should be reconfirmed at the time of purchase. Up-to-date engineering data, free product selection software, and more can be found at BaltimoreAircoil.com.

XE Model Data

Model Number	Nominal Tonnage ⁽¹⁾	Motor HP	Fan (CFM)	Weights (lbs)			Dimensions ⁽³⁾			
				Operating ⁽²⁾	Shipping	Heaviest Section	L	W	H ⁽⁴⁾	A
XES3E-8518-05G	171	3	46,830	15,000	7,860	7,860	8'-6"	18'-1"	9'-10"	8'-8"
XES3E-8518-05H	203	5	54,950	15,010	7,870	7,870	8'-6"	18'-1"	9'-10"	8'-8"
XES3E-8518-05J	233	7.5	62,370	15,040	7,900	7,900	8'-6"	18'-1"	9'-10"	8'-8"
XES3E-8518-05K	256	10	68,230	15,050	7,910	7,910	8'-6"	18'-1"	9'-10"	8'-8"
XES3E-8518-06G	194	3	51,200	15,910	8,240	8,240	8'-6"	18'-1"	11'-2"	10'-0"
XES3E-8518-06H	230	5	60,000	15,920	8,250	8,250	8'-6"	18'-1"	11'-2"	10'-0"
XES3E-8518-06J	262	7.5	68,010	15,950	8,280	8,280	8'-6"	18'-1"	11'-2"	10'-0"
XES3E-8518-06K	288	10	74,310	15,960	8,290	8,290	8'-6"	18'-1"	11'-2"	10'-0"
XES3E-8518-07G	216	3	55,510	18,190	8,620	8,620	8'-6"	18'-1"	12'-6"	11'-4"
XES3E-8518-07H	256	5	64,950	18,200	8,630	8,630	8'-6"	18'-1"	12'-6"	11'-4"
XES3E-8518-07J	292	7.5	73,520	18,230	8,660	8,660	8'-6"	18'-1"	12'-6"	11'-4"
XES3E-8518-07K	320	10	80,250	18,240	8,670	8,670	8'-6"	18'-1"	12'-6"	11'-4"
XES3E-8518-07L	365	15	90,740	18,310	8,740	8,740	8'-6"	18'-1"	12'-6"	11'-4"
XES3E-1020-06G	206	3	54,620	19,020	9,420	9,420	9'-10"	20'-1"	10'-10"	10'-0"
XES3E-1020-06H	244	5	64,020	19,030	9,430	9,430	9'-10"	20'-1"	10'-10"	10'-0"
XES3E-1020-06J	279	7.5	72,540	19,040	9,440	9,440	9'-10"	20'-1"	10'-10"	10'-0"
XES3E-1020-06K	307	10	79,230	19,050	9,450	9,450	9'-10"	20'-1"	10'-10"	10'-0"
XES3E-1020-06L	350	15	89,680	19,120	9,520	9,520	9'-10"	20'-1"	10'-10"	10'-0"
XES3E-1020-07G	228	3	59,110	20,040	9,750	9,750	9'-10"	20'-1"	12'-2"	11'-4"
XES3E-1020-07H	271	5	69,240	20,050	9,760	9,760	9'-10"	20'-1"	12'-2"	11'-4"
XES3E-1020-07J	310	7.5	78,450	20,080	9,790	9,790	9'-10"	20'-1"	12'-2"	11'-4"
XES3E-1020-07K	340	10	85,680	20,090	9,800	9,800	9'-10"	20'-1"	12'-2"	11'-4"
XES3E-1020-07L	388	15	96,960	20,160	9,870	9,870	9'-10"	20'-1"	12'-2"	11'-4"
XES3E-1222-06H	279	5	73,400	23,530	11,250	11,250	11'-10"	21'-7"	10'-11"	10'-0"
XES3E-1222-06J	318	7.5	83,170	23,560	11,280	11,280	11'-10"	21'-7"	10'-11"	10'-0"
XES3E-1222-06K	350	10	90,860	23,570	11,290	11,290	11'-10"	21'-7"	10'-11"	10'-0"
XES3E-1222-06L	399	15	102,870	23,640	11,360	11,360	11'-10"	21'-7"	10'-11"	10'-0"
XES3E-1222-07J	354	7.5	90,050	24,910	11,880	11,880	11'-10"	21'-7"	12'-3"	11'-4"
XES3E-1222-07K	389	10	98,370	24,920	11,890	11,890	11'-10"	21'-7"	12'-3"	11'-4"
XES3E-1222-07L	444	15	111,350	24,990	11,960	11,960	11'-10"	21'-7"	12'-3"	11'-4"
XES3E-1222-07M	487	20	121,530	25,010	11,980	11,980	11'-10"	21'-7"	12'-3"	11'-4"
XES3E-1222-10K	491	10	120,030	33,090	14,910	8,590	11'-10"	21'-7"	16'-5"	15'-6"
XES3E-1222-10L	559	15	135,400	33,160	14,980	8,660	11'-10"	21'-7"	16'-5"	15'-6"
XES3E-1222-10M	611	20	147,380	33,180	15,000	8,680	11'-10"	21'-7"	16'-5"	15'-6"
XES3E-1222-10N	655	25	157,340	33,320	15,140	8,820	11'-10"	21'-7"	16'-5"	15'-6"
XES3E-1222-10O	693	30	165,950	33,370	15,190	8,870	11'-10"	21'-7"	16'-5"	15'-6"
XES3E-1222-12K	528	10	127,800	35,830	15,840	8,700	11'-10"	21'-7"	19'-1"	18'-2"
XES3E-1222-12L	600	15	144,070	35,900	15,910	8,770	11'-10"	21'-7"	19'-1"	18'-2"
XES3E-1222-12M	657	20	156,730	35,920	15,930	8,790	11'-10"	21'-7"	19'-1"	18'-2"
XES3E-1222-12N	703	25	167,230	36,060	16,070	8,930	11'-10"	21'-7"	19'-1"	18'-2"
XES3E-1222-12O	744	30	176,300	36,110	16,120	8,980	11'-10"	21'-7"	19'-1"	18'-2"

Model Number	Nominal Tonnage ⁽¹⁾	Motor HP	Fan (CFM)	Weights (lbs)			Dimensions ⁽³⁾			
				Operating ⁽²⁾	Shipping	Heaviest Section	L	W	H ⁽⁴⁾	A
XES3E-1222-13K	545	10	131,530	36,750	16,300	8,700	11'-10"	21'-7"	20'-5"	19'-6"
XES3E-1222-13L	620	15	148,260	36,820	16,370	8,770	11'-10"	21'-7"	20'-5"	19'-6"
XES3E-1222-13M	678	20	161,250	36,840	16,390	8,790	11'-10"	21'-7"	20'-5"	19'-6"
XES3E-1222-13N	727	25	172,040	36,980	16,530	8,930	11'-10"	21'-7"	20'-5"	19'-6"
XES3E-1222-13O	769	30	181,340	37,030	16,580	8,980	11'-10"	21'-7"	20'-5"	19'-6"
XES3E-1222-14L	645	15	153,570	37,240	16,800	9,250	11'-10"	21'-7"	21'-9"	20'-10"
XES3E-1222-14M	706	20	167,020	37,260	16,820	9,270	11'-10"	21'-7"	21'-9"	20'-10"
XES3E-1222-14N	756	25	178,170	37,400	16,960	9,410	11'-10"	21'-7"	21'-9"	20'-10"
XES3E-1222-14O	799	30	187,780	37,450	17,010	9,460	11'-10"	21'-7"	21'-9"	20'-10"
XES3E-1424-07J	396	7.5	101,080	34,210	16,170	16,170	14'-0"	24'-1"	12'-4"	11'-4"
XES3E-1424-07K	435	10	110,430	34,220	16,180	16,180	14'-0"	24'-1"	12'-4"	11'-4"
XES3E-1424-07L	497	15	125,010	34,290	16,250	16,250	14'-0"	24'-1"	12'-4"	11'-4"
XES3E-1424-07M	545	20	136,450	34,310	16,270	16,270	14'-0"	24'-1"	12'-4"	11'-4"
XES3E-1424-07N	585	25	146,010	34,450	16,410	16,410	14'-0"	24'-1"	12'-4"	11'-4"
XES3E-1424-12L	691	15	166,130	44,070	21,230	11,490	14'-0"	24'-1"	19'-3"	18'-2"
XES3E-1424-12M	755	20	180,510	44,090	21,250	11,510	14'-0"	24'-1"	19'-3"	18'-2"
XES3E-1424-12N	808	25	192,440	44,230	21,390	11,650	14'-0"	24'-1"	19'-3"	18'-2"
XES3E-1424-12O	854	30	202,710	44,280	21,440	11,700	14'-0"	24'-1"	19'-3"	18'-2"
XES3E-1424-12P	931	40	219,990	44,420	21,580	11,840	14'-0"	24'-1"	19'-3"	18'-2"
XES3E-1424-13L	717	15	171,590	45,450	21,620	11,490	14'-0"	24'-1"	20'-7"	19'-6"
XES3E-1424-13M	783	20	186,380	45,470	21,640	11,510	14'-0"	24'-1"	20'-7"	19'-6"
XES3E-1424-13N	838	25	198,630	45,610	21,780	11,650	14'-0"	24'-1"	20'-7"	19'-6"
XES3E-1424-13O	885	30	209,190	45,660	21,830	11,700	14'-0"	24'-1"	20'-7"	19'-6"
XES3E-1424-13P	965	40	226,910	45,800	21,970	11,840	14'-0"	24'-1"	20'-7"	19'-6"
XES3E-1424-14M	817	20	193,670	47,050	22,030	12,260	14'-0"	24'-1"	21'-11"	20'-10"
XES3E-1424-14N	874	25	206,360	47,190	22,170	12,400	14'-0"	24'-1"	21'-11"	20'-10"
XES3E-1424-14O	924	30	217,270	47,240	22,220	12,450	14'-0"	24'-1"	21'-11"	20'-10"
XES3E-1424-14P	1,007	40	235,600	47,380	22,360	12,590	14'-0"	24'-1"	21'-11"	20'-10"



NOTES FOR XE MODEL UNITS:

- Nominal tons of cooling represents the capability to cool 3 USGPM of water from a 95°F entering water temperature to an 85°F leaving water temperature at a 78°F entering wet-bulb temperature.
- Operating weight is based on the water level in the cold water basin at overflow height. If a lower operating weight is needed to meet design requirements, your local BAC Representative can provide additional assistance.
- Refer to **page C15** for dimensional reference drawings.
- Models shipped with an optional gear drive or Low Sound Fan may have heights up to 10.5" greater than shown. For units with Whisper Quiet Fans please contact your local BAC Representative for accurate height dimensions.

Do not use for construction. Refer to factory certified dimensions. This catalog includes data current at the time of publication, which should be reconfirmed at the time of purchase. Up-to-date engineering data, free product selection software, and more can be found at BaltimoreAircoil.com.

Series 3000 Double Cell Data

Model Number	Nominal Tonnage ⁽³⁾	Motor HP	Fan (CFM)	Weights (lbs)			Dimensions ⁽⁵⁾			
				Operating ⁽⁴⁾	Shipping	Heaviest Section	L	W	H ⁽⁶⁾	A
S3E-8518-05L-2	585	30	154,820	30,340	16,060	8,030	17'-3"	18'-1"	9'-10"	8'-8"
S3E-8518-05M-2	643	40	169,240	30,460	16,180	8,090	17'-3"	18'-1"	9'-10"	8'-8"
S3E-8518-06L-2	658	30	168,340	32,060	16,720	8,360	17'-3"	18'-1"	11'-2"	10'-0"
S3E-8518-06M-2	723	40	183,860	32,100	16,760	8,380	17'-3"	18'-1"	11'-2"	10'-0"
S3E-8518-06N-2	776	50	196,840	32,160	16,820	8,410	17'-3"	18'-1"	11'-2"	10'-0"
S3E-8518-06O-2	813	60	208,120	32,260	16,920	8,460	17'-3"	18'-1"	11'-2"	10'-0"
S3E-8518-07M-2	800	40	197,940	36,660	17,520	8,760	17'-3"	18'-1"	12'-6"	11'-4"
S3E-8518-07N-2	858	50	211,720	36,720	17,580	8,790	17'-3"	18'-1"	12'-6"	11'-4"
S3E-8518-07O-2	903	60	223,660	36,820	17,680	8,840	17'-3"	18'-1"	12'-6"	11'-4"
S3E-8518-07P-2	968	80	243,880	37,140	18,000	9,000	17'-3"	18'-1"	12'-6"	11'-4"
S3E-1020-06M-2	767	40	195,800	38,280	19,080	9,540	19'-10"	20'-1"	10'-10"	10'-0"
S3E-1020-06N-2	823	50	209,520	38,560	19,360	9,680	19'-10"	20'-1"	10'-10"	10'-0"
S3E-1020-06O-2	872	60	221,460	38,660	19,460	9,730	19'-10"	20'-1"	10'-10"	10'-0"
S3E-1020-07M-2	851	40	211,620	40,360	19,780	9,890	19'-10"	20'-1"	12'-2"	11'-4"
S3E-1020-07N-2	913	50	226,400	40,640	20,060	10,030	19'-10"	20'-1"	12'-2"	11'-4"
S3E-1020-07O-2	968	60	239,220	40,740	20,160	10,080	19'-10"	20'-1"	12'-2"	11'-4"
S3E-1020-07P-2	1,060	80	260,880	41,060	20,480	10,240	19'-10"	20'-1"	12'-2"	11'-4"
S3E-1222-06M-2	877	40	224,620	47,320	22,760	11,380	23'-11"	21'-7"	10'-11"	10'-0"
S3E-1222-06N-2	942	50	240,400	47,600	23,040	11,520	23'-11"	21'-7"	10'-11"	10'-0"
S3E-1222-06O-2	999	60	254,100	47,700	23,140	11,570	23'-11"	21'-7"	10'-11"	10'-0"
S3E-1222-07N-2	1,046	50	260,080	50,300	24,240	12,120	23'-11"	21'-7"	12'-3"	11'-4"
S3E-1222-07O-2	1,109	60	274,820	50,400	24,340	12,170	23'-11"	21'-7"	12'-3"	11'-4"
S3E-1222-07P-2	1,215	80	299,720	50,720	24,660	12,330	23'-11"	21'-7"	12'-3"	11'-4"
S3E-1222-07Q-2	1,303	100	320,560	50,740	24,680	12,340	23'-11"	21'-7"	12'-3"	11'-4"
S3E-1222-07R-2	1,380	120	338,640	52,260	26,200	13,100	23'-11"	21'-7"	12'-9"	11'-4"
S3E-1222-10P-2	1,514	80	360,900	67,020	30,660	9,010	23'-11"	21'-7"	16'-5"	15'-6"
S3E-1222-10Q-2	1,621	100	385,080	67,340	30,980	9,170	23'-11"	21'-7"	16'-5"	15'-6"
S3E-1222-10R-2	1,712	120	406,020	67,360	31,000	9,180	23'-11"	21'-7"	16'-5"	15'-6"
S3E-1222-10S-2	1,832	150	433,260	69,280	32,920	10,140	23'-11"	21'-7"	16'-5"	15'-6"
S3E-1222-12P-2	1,624	80	383,100	72,500	32,520	9,120	23'-11"	21'-7"	19'-1"	18'-2"
S3E-1222-12Q-2	1,737	100	408,500	72,620	32,640	9,180	23'-11"	21'-7"	19'-1"	18'-2"
S3E-1222-12R-2	1,835	120	430,500	73,040	33,060	9,390	23'-11"	21'-7"	19'-1"	18'-2"
S3E-1222-12S-2	1,961	150	459,040	74,960	34,980	10,350	23'-11"	21'-7"	19'-1"	18'-2"
S3E-1222-13P-2	1,678	80	393,960	74,340	33,440	9,120	23'-11"	21'-7"	20'-5"	19'-6"
S3E-1222-13Q-2	1,794	100	419,980	74,460	33,560	9,180	23'-11"	21'-7"	20'-5"	19'-6"
S3E-1222-13R-2	1,895	120	442,480	74,880	33,980	9,390	23'-11"	21'-7"	20'-5"	19'-6"
S3E-1222-13S-2	2,025	150	471,700	75,040	34,140	9,470	23'-11"	21'-7"	20'-5"	19'-6"

Model Number	Nominal Tonnage ⁽³⁾	Motor HP	Fan (CFM)	Weights (lbs)			Dimensions ⁽⁵⁾			
				Operating ⁽⁴⁾	Shipping	Heaviest Section	L	W	H ⁽⁶⁾	A
S3E-1222-14P-2	1,744	80	407,860	75,180	34,300	9,600	23'-11"	21'-7"	21'-9"	20'-10"
S3E-1222-14Q-2	1,866	100	434,720	75,300	34,420	9,660	23'-11"	21'-7"	21'-9"	20'-10"
S3E-1222-14R-2	1,970	120	457,940	75,620	34,740	9,820	23'-11"	21'-7"	21'-9"	20'-10"
S3E-1222-14S-2	2,112	150	488,060	75,780	34,900	9,900	23'-11"	21'-7"	21'-9"	20'-10"
S3E-1222-14T-2 ⁽¹⁾	2,294	200	530,000	79,620	38,740	10,990	23'-11"	21'-7"	21'-9"	20'-10"
S3E-1424-07O-2	1,241	60	308,580	69,000	32,920	16,460	28'-2"	24'-1"	12'-4"	11'-4"
S3E-1424-07P-2	1,360	80	336,560	69,320	33,240	16,620	28'-2"	24'-1"	12'-4"	11'-4"
S3E-1424-07Q-2	1,459	100	359,860	69,340	33,260	16,630	28'-2"	24'-1"	12'-4"	11'-4"
S3E-1424-07R-2	1,545	120	379,960	69,360	33,280	16,640	28'-2"	24'-1"	12'-4"	11'-4"
S3E-1424-12Q-2	1,989	100	468,680	88,960	43,280	11,900	28'-2"	24'-1"	19'-3"	18'-2"
S3E-1424-12R-2	2,099	120	493,520	89,280	43,600	12,060	28'-2"	24'-1"	19'-9"	18'-2"
S3E-1424-12S-2	2,242	150	525,720	89,380	43,700	12,110	28'-2"	24'-1"	19'-9"	18'-2"
S3E-1424-12T-2 ⁽¹⁾	2,414	200	559,100	93,220	47,540	13,200	28'-2"	24'-1"	20'-1"	18'-2"
S3E-1424-13Q-2	2,062	100	483,280	91,720	44,060	11,900	28'-2"	24'-1"	20'-7"	19'-6"
S3E-1424-13R-2	2,175	120	508,720	92,040	44,380	12,060	28'-2"	24'-1"	21'-1"	19'-6"
S3E-1424-13S-2	2,322	150	541,720	92,140	44,480	12,110	28'-2"	24'-1"	21'-1"	19'-6"
S3E-1424-13T-2 ⁽¹⁾	2,500	200	575,860	95,980	48,320	13,200	28'-2"	24'-1"	21'-5"	19'-6"
S3E-1424-14Q-2	2,150	100	501,620	94,880	44,840	12,650	28'-2"	24'-1"	21'-11"	20'-10"
S3E-1424-14R-2	2,268	120	527,900	95,200	45,160	12,810	28'-2"	24'-1"	22'-5"	20'-10"
S3E-1424-14S-2	2,431	150	561,980	95,300	45,260	12,860	28'-2"	24'-1"	22'-5"	20'-10"
S3E-1424-14T-2 ⁽¹⁾	2,605	200	600,400	99,140	49,100	13,950	28'-2"	24'-1"	22'-9"	20'-10"
S3E-1424-14U-2 ⁽²⁾	2,748	238	633,260	100,560	50,520	14,660	28'-2"	24'-1"	22'-5"	20'-10"
S3E-1424-14W-2 ⁽²⁾	2,787	250	642,320	100,560	50,520	14,660	28'-2"	24'-1"	22'-5"	20'-10"



NOTES FOR SINGLE CELL UNITS:

1. S3E-1222-14T, S3E-1424-12T, S3E-1424-13T and S3E-1424-14T are supplied with a gear drive system as standard.
2. S3E-1424-14U and S3E-1424-14W are supplied with the ENDURADRIIVE® Fan System as standard.
3. Nominal tons of cooling represents the capability to cool 3 USGPM of water from a 95°F entering water temperature to an 85°F leaving water temperature at a 78°F entering wet-bulb temperature.
4. Operating weight is based on the water level in the cold water basin at overflow height. If a lower operating weight is needed to meet design requirements, your local BAC Representative can provide additional assistance.
5. Refer to **page C15** for dimensional reference drawings.
6. Models shipped with an optional gear drive or Low Sound Fan may have heights up to 10.5" greater than shown. For units with Whisper Quiet Fans please contact your local BAC Representative for accurate height dimensions.

Do not use for construction. Refer to factory certified dimensions. This catalog includes data current at the time of publication, which should be reconfirmed at the time of purchase. Up-to-date engineering data, free product selection software, and more can be found at BaltimoreAircoil.com.

Series 3000 Connection Data

Model Number	Dimensions ⁽¹⁾				Inlet Connection Sizes ^(2,4)		Outlet Connection Sizes ^(3,4)	
	B	C	D	F	Easy Connect	Top Inlet	Outlet	Remote Sump
S3E/XES3E-8518-05x	5'-9"	3'-9"	9"	6'-6"	8"	(2) 6"	8"	10"
S3E/XES3E-8518-06x	6'-7"	3'-9"	9"	6'-6"	8"	(2) 6"	8"	10"
S3E/XES3E-8518-07x	6'-7"	3'-9"	10"	6'-6"	10"	(2) 8"	10"	12"
S3E/XES3E-1020-06x	6'-7"	3'-9"	10"	6'-9"	10"	(2) 8"	10"	12"
S3E/XES3E-1020-07x	6'-7"	3'-9"	10"	6'-9"	10"	(2) 8"	10"	12"
S3E/XES3E-1222-06x	6'-7"	4'-0"	10"	8'-8"	10"	(2) 8"	10"	12"
S3E/XES3E-1222-07x	6'-7"	4'-0"	10"	8'-8"	10"	(2) 8"	10"	14"
S3E/XES3E-1222-10x	10'-5"	4'-0"	10"	8'-8"	12"	(2) 8"	12"	16"
S3E/XES3E-1222-12x	13'-1"	4'-0"	10"	8'-8"	12"	(2) 8"	12"	16"
S3E/XES3E-1222-13x	14'-5"	4'-0"	10"	8'-8"	12"	(2) 8"	12"	18"
S3E/XES3E-1222-14x	15'-9"	4'-0"	10"	8'-8"	14"	(2) 10"	14"	20"
S3E/XES3E-1424-07x	6'-7"	4'-1"	10"	8'-10"	12"	(2) 8"	12"	16"
S3E/XES3E-1424-12x	13'-1"	4'-1"	10"	8'-10"	14"	(2) 10"	14"	20"
S3E/XES3E-1424-13x	14'-5"	4'-1"	10"	8'-10"	14"	(2) 10"	14"	20"
S3E/XES3E-1424-14x	15'-9"	4'-1"	10"	8'-10"	14"	(2) 10"	14"	20"



NOTES FOR CONNECTION DIMENSIONS:

1. For dimension locations, see **page C23**.
2. The specific size of the inlet and outlet connection may vary with the design cooling water flow rate.
3. Unless otherwise indicated, all connections 3" and smaller are male pipe thread, and connections 4" and larger are beveled for welding and grooved to suit a mechanical coupling.
4. On double cell units, connections are the same size but are located on both ends of the unit. Refer to **page C15** for side elevation view.

Do not use for construction. Refer to factory certified dimensions. This catalog includes data current at the time of publication, which should be reconfirmed at the time of purchase. Up-to-date engineering data, free product selection software, and more can be found at BaltimoreAircoil.com.

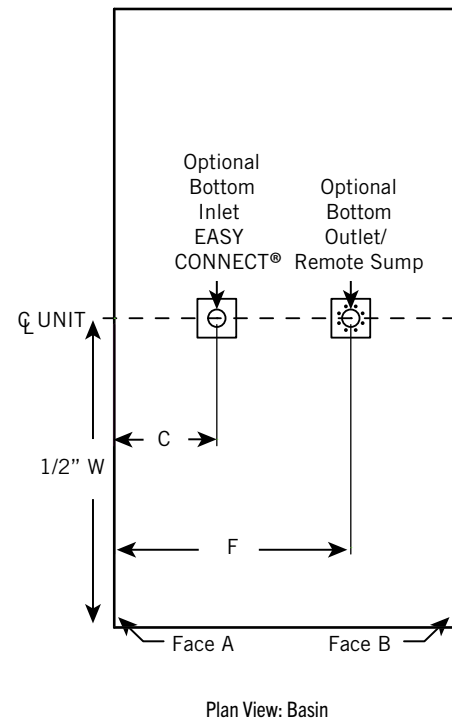
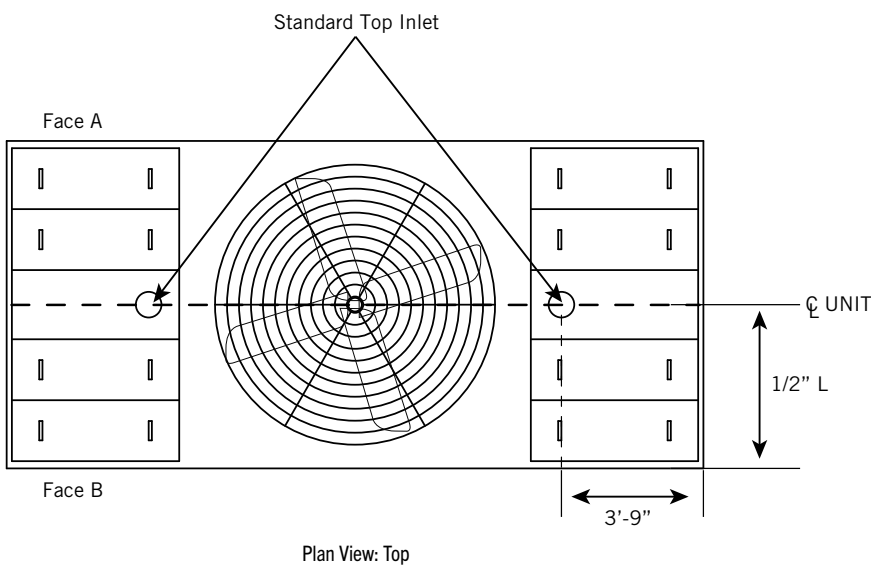
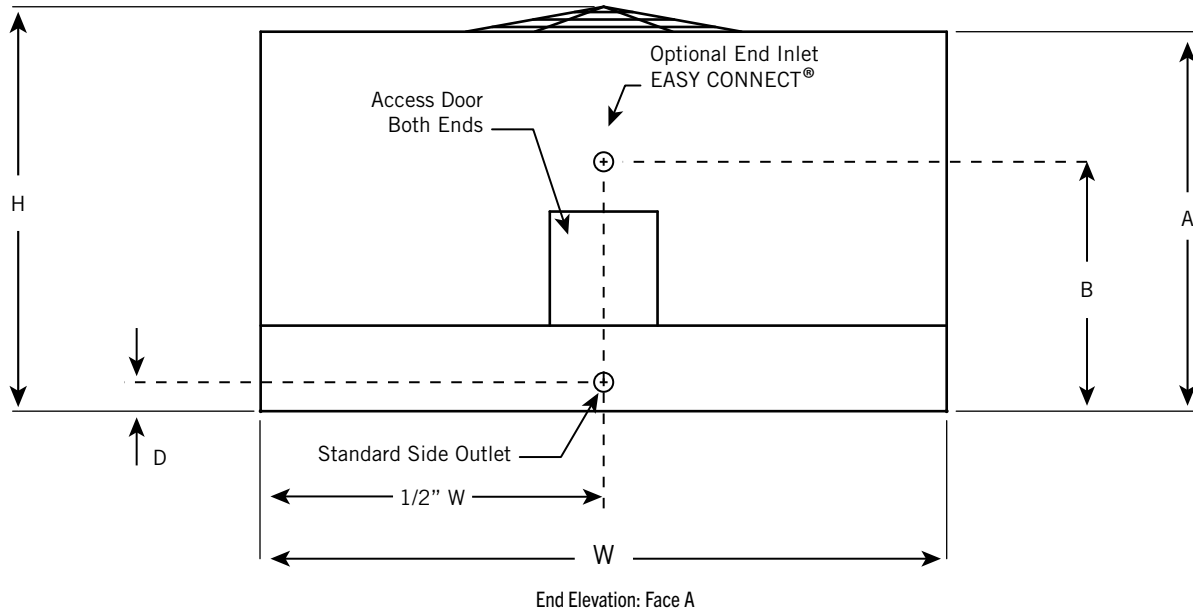

Series 3000 Connection Data

Concrete Basin Engineering Data for Optional Basinless Units

Model Number	Operating Load Vertical (lbs)	Maximum Operating Weight (lbs)	A	B	C	D
S3E/XES3E-8518-05x	1,830	10,980	9'-0 3/4"	18'-4 1/2"	9'-2 1/4"	-
S3E/XES3E-8518-06x	1,990	11,890	9'-0 3/4"	18'-4 1/2"	9'-2 1/4"	-
S3E/XES3E-8518-07x	2,390	14,320	9'-0 3/4"	18'-4 1/2"	9'-2 1/4"	-
S3E/XES3E-1020-06x	2,350	14,070	10'-5 1/4"	20'-4 1/2"	10'-2 1/4"	-
S3E/XES3E-1020-07x	2,550	15,270	10'-5 1/4"	20'-4 1/2"	10'-2 1/4"	-
S3E/XES3E-1222-06x	2,800	16,750	12'-5 3/4"	21'-10 1/2"	10'-11 1/4"	-
S3E/XES3E-1222-07x	3,180	19,030	12'-5 3/4"	21'-10 1/2"	10'-11 1/4"	-
S3E/XES3E-1222-10x	4,450	26,690	12'-5 3/4"	21'-10 1/2"	10'-11 1/4"	-
S3E/XES3E-1222-12x	4,930	29,530	12'-5 3/4"	21'-10 1/2"	10'-11 1/4"	-
S3E/XES3E-1222-13x	4,930	29,570	12'-5 3/4"	21'-10 1/2"	10'-11 1/4"	-
S3E/XES3E-1222-14x	5,320	31,870	12'-5 3/4"	21'-10 1/2"	10'-11 1/4"	-
S3E/XES3E-1424-07x	3,020	24,110	14'-7 1/8"	24'-4 1/2"	7'-8 1/4"	9'-0"
S3E/XES3E-1424-12x	4,580	36,570	14'-7 1/8"	24'-4 1/2"	7'-8 1/4"	9'-0"
S3E/XES3E-1424-13x	4,750	37,950	14'-7 1/8"	24'-4 1/2"	7'-8 1/4"	9'-0"
S3E/XES3E-1424-14x	5,030	40,240	14'-7 1/8"	24'-4 1/2"	7'-8 1/4"	9'-0"



NOTES FOR BASINLESS DATA:

1. Purchaser to design, construct, and furnish basin (including anchor bolts) in accordance with requirements given. Purchaser must also supply sump, overflow, drain, cleanout, and water make-up to suit requirements.
2. All anchor bolts shall be 3/4" diameter, 1 1/2" projection ($\pm 1/4"$), fully threaded. Bolt to have one nut and washer. Anchor bolt and column bearing point locations and elevations must be maintained $\pm 1/8"$.
3. Pier dimensions shown are minimum bearing surfaces required for the tower structure and do not include corner chamfers on the concrete piers.
4. Fill to be located below the operating water level (see Side View of Concrete Basin for All Models on **page C23**).
5. Maximum operating weight does not include concrete basin or water retained in the basin.

Do not use for construction. Refer to factory certified dimensions. This catalog includes data current at the time of publication, which should be reconfirmed at the time of purchase. Up-to-date engineering data, free product selection software, and more can be found at BaltimoreAircoil.com.

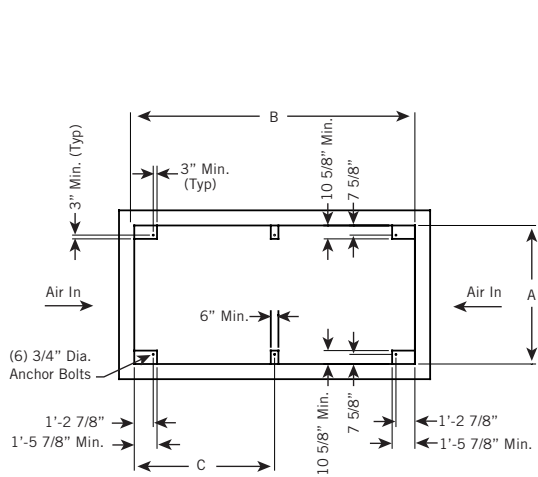

Plan View of Concrete Basin:
Models S3E/XES3E-8518-X, S3E/XES3E-1020-X,
and S3E/XES3E-1222-X

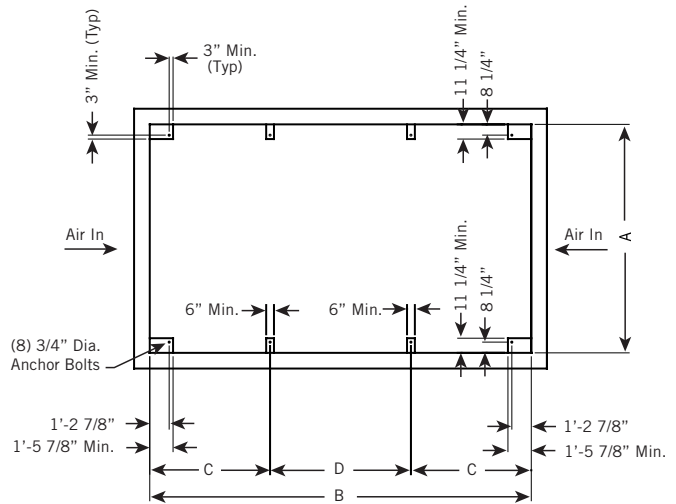

Plan View of Concrete Basin:
Model S3E/XES3E-1424-X

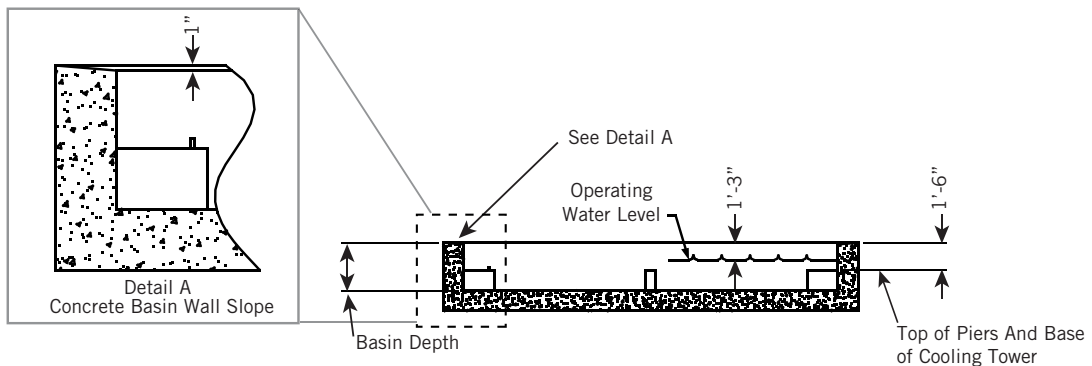

Side View of Concrete Basin: All Models

Series 3000 Structural Support

The recommended support arrangement for the Series 3000 Cooling Tower consists of parallel structural members positioned as shown in the drawings on [page C27](#). In addition to providing adequate support, the members also serve to raise the unit above any solid foundation to assure access to the bottom of the tower. The Series 3000 Cooling Tower may also be supported on columns at the anchor bolt locations shown in Plan A (single cell) or Plan C (double cell). Alternate support arrangements can be found on [page C28](#). To support a Series 3000 Cooling Tower on columns with an alternate steel support arrangement or the optional upgraded seismic and wind rated unit, consult your local BAC Representative.

Model Number	Weights (lbs)			Dimensions						
	Operating	Shipping	WT. at Bolt Hole Locations	L1	L2	W	A	B	C	D
S3E/XES3E-8518-05x	15,230	8,090	3,810	8'-5 3/4"	17'-2"	18'-0 1/2"	9'-4"	1 1/8"	8'-3 1/2"	4 3/4"
S3E/XES3E-8518-06x	16,130	8,460	4,040	8'-5 3/4"	17'-2"	18'-0 1/2"	9'-4"	1 1/8"	8'-3 1/2"	4 3/4"
S3E/XES3E-8518-07x	18,570	9,000	4,650	8'-5 3/4"	17'-2"	18'-0 1/2"	9'-4"	1 1/8"	8'-3 1/2"	4 3/4"
S3E/XES3E-1020-06x	19,330	9,730	4,840	9'-9 1/4"	19'-9"	20'-0 1/2"	11'-4"	1 1/8"	9'-7"	4 3/4"
S3E/XES3E-1020-07x	20,530	10,240	5,140	9'-9 1/4"	19'-9"	20'-0 1/2"	11'-4"	1 1/8"	9'-7"	4 3/4"
S3E/XES3E-1222-06x	23,850	11,570	5,970	11'-9 3/4"	23'-10"	21'-6 1/2"	12'-10"	1 1/8"	11'-7 1/2"	4 3/4"
S3E/XES3E-1222-07x	26,130	13,100	6,540	11'-9 3/4"	23'-10"	21'-6 1/2"	12'-10"	1 1/8"	11'-7 1/2"	4 3/4"
S3E/XES3E-1222-10x	34,640	16,460	8,660	11'-9 3/4"	23'-10"	21'-6 1/2"	12'-10"	1 1/8"	11'-7 1/2"	4 3/4"
S3E/XES3E-1222-12x	37,480	17,490	9,370	11'-9 3/4"	23'-10"	21'-6 1/2"	12'-10"	1 1/8"	11'-7 1/2"	4 3/4"
S3E/XES3E-1222-13x	37,520	17,070	9,380	11'-9 3/4"	23'-10"	21'-6 1/2"	12'-10"	1 1/8"	11'-7 1/2"	4 3/4"
S3E/XES3E-1222-14x	39,810	19,370	9,960	11'-9 3/4"	23'-10"	21'-6 1/2"	12'-10"	1 1/8"	11'-7 1/2"	4 3/4"
S3E/XES3E-1424-07x	34,680	16,640	8,670	13'-11 1/8"	28'-0 3/4"	24'-0 1/2"	15'-4"	1 7/16"	13'-8 1/4"	5 3/8"
S3E/XES3E-1424-12x	46,610	23,770	11,660	13'-11 1/8"	28'-0 3/4"	24'-0 1/2"	15'-4"	1 7/16"	13'-8 1/4"	5 3/8"
S3E/XES3E-1424-13x	47,990	24,160	12,000	13'-11 1/8"	28'-0 3/4"	24'-0 1/2"	15'-4"	1 7/16"	13'-8 1/4"	5 3/8"
S3E/XES3E-1424-14x	50,280	25,260	12,570	13'-11 1/8"	28'-0 3/4"	24'-0 1/2"	15'-4"	1 7/16"	13'-8 1/4"	5 3/8"



NOTES FOR BASINLESS DATA:

1. Support members and anchor bolts shall be designed, furnished, and installed by others.
2. Design of support members and anchor bolts shall be in accordance with the strength and serviceability requirements of the applicable building code and project specifications.
3. Support members shall be level at the top.
4. Refer to the certified unit support drawing for loading and additional support requirements.
5. For support spacing other than shown, mounting holes in the unit are to be drilled by others.

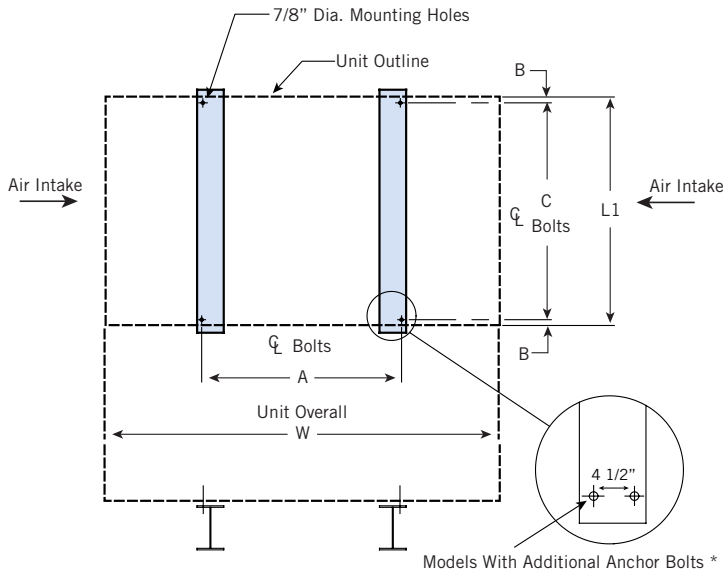

Plan A: Single Cell Unit

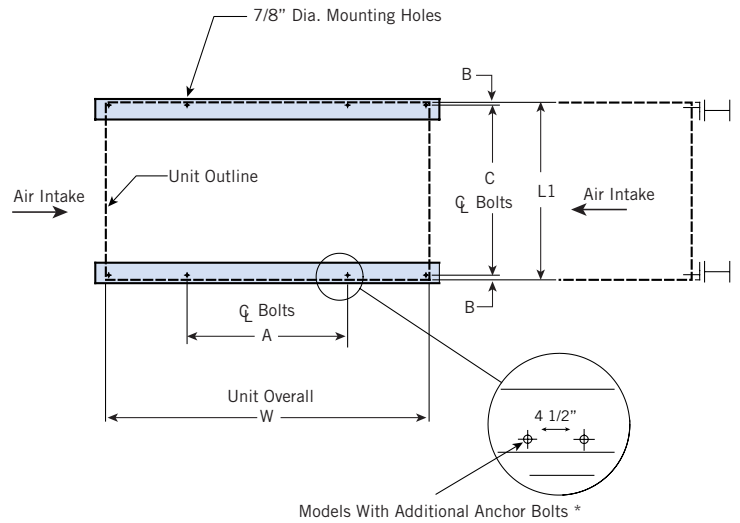

Plan B: Single Cell Unit

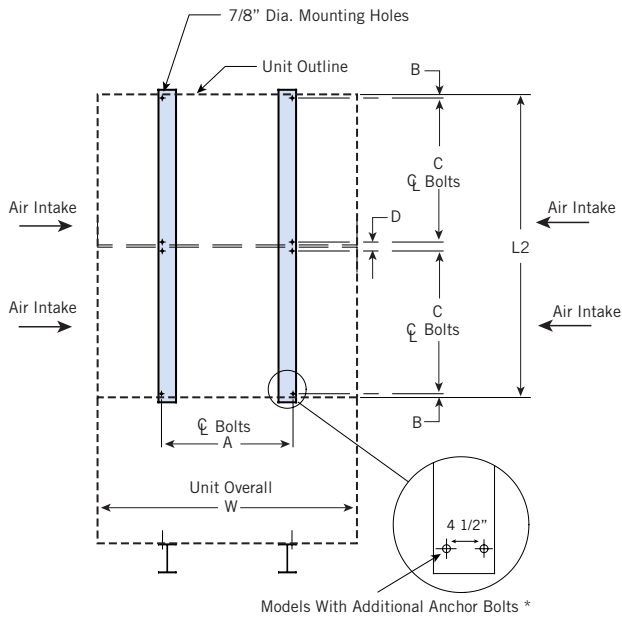

Plan C: Double Cell Unit

Models With Additional Anchor Bolts	
Model Number	Quantity of Bolts
S3E/XES3E-8518-05x	4
S3E/XES3E-8518-06x	4
S3E/XES3E-8518-07x	4
S3E/XES3E-1020-06x	4
S3E/XES3E-1020-07x	4
S3E/XES3E-1222-06x	4
S3E/XES3E-1222-07x	4
S3E/XES3E-1222-10x*	8
S3E/XES3E-1222-12x*	8
S3E/XES3E-1222-13x*	8
S3E/XES3E-1222-14x*	8
S3E/XES3E-1424-07x	4
S3E/XES3E-1424-12x*	8
S3E/XES3E-1424-13x*	8
S3E/XES3E-1424-14x*	8

Series 3000

Alternative Structural Support

The Series 3000 Cooling Towers (excluding basinless option) can accommodate Plan A (single cell) and Plan C (double cell) support with alternative spacing of anchor bolt hole center lines as listed in the table below. BAC provides specific anchorage drawings in the job file that reflect the revised anchor bolt hole center line dimension only. The unit will have pre-punched anchor bolt holes in the standard and minimum hole spacing locations only. All other alternative anchor bolt holes are located and drilled by others.

Model Number	Standard Spacing "A" Dimension	Spacing Range to Avoid due to Cold Water Basins Seams Interfere with Bolt Hole Locations	Maximum Spacing "A" Dimension	Minimum Spacing "A" Dimension
S3E/XES3E-8518-x	9'-4"	8'-5 1/2" thru 7'-9 3/8"	16'-0"	7'-5"
S3E/XES3E-1020-x	11'-4"	10'-1 3/4" thru 9'-5 5/8"	16'-0"	8'-0"
S3E/XES3E-1222-x	12'-10"	11'-2 3/4" thru 11'-10 7/8"	16'-0"	9'-6"
S3E/XES3E-1424-x	15'-4"	--	16'-0"	12'-0"



NOTE:

1. The standard structural support figures on **page C27** apply to alternative structural support as well.