



Product Catalog

Model #: RTHDUD1F XR0UAD1W 3LAL1D2 LALAVCQA EXABXXY3 42FRXT7X XXXXVXX
Serial #: U18D00701

Year: 2018
Size: 350 Tons

Optimus™ Water-Cooled Chillers Model RTHD

150 to 430 (60 Hz) Nominal Tons
125 to 430 (50 Hz) Nominal Tons



Shipping Weight: 14,443 lbs.
Operating Weight: 15,385 lbs.

L: 10' 6" W: 5' 8" H: 6' 5"

August 2016

RLC-PRC020H-EN





Model Number Descriptions

RTHDUD1F XR0UAD1W 3LAL1D2 LALAVCQA EXABXXY3 42FRXT7X XXXXVXX

Digits 1 - 4 – Chiller Model

RTHD= Water-Cooled Optimus™ Chiller

Digit 5 – Manufacturing Location

U = Water Chiller Business Unit, Pueblo, CO USA

Digits 6, 7 – Compressor Frame

- B1 = B1 Compressor
- B2 = B2 Compressor
- C1 = C1 Compressor
- C2 = C2 Compressor
- D1 = D1 Compressor
- D2 = D2 Compressor
- D3 = D3 Compressor (50 hz only)
- E3 = E3 Compressor (50 hz only)

Digits 8 – Unit Power Supply

- A = 200V/60Hz/3Ph power
- C = 230V/60Hz/3Ph power
- D = 380V/60Hz/3Ph power
- F = 460V/60Hz/3Ph power
- H = 575V/60Hz/3Ph power
- R = 380V/50Hz/3Ph power
- T = 400V/50Hz/3Ph power
- U = 415V/50Hz/3Ph power

Digit 9 – Specials

X = No Specials

Digit 10, 11 – Design Sequence

** = Factory assigned

Digit 12 – Agency Listing

- X = No Agency Listing
- U = UL Listed to US and Canadian Safety Standard
- A = IBC Seismically Rated
- B = UL/Canadian and IBC
- C = OSHPD Seismically Rated
- D = UL/Canadian and OSHPD

Note: Digit 12 selections A, B, C & D are special order only.

Digit 13 – Pressure Vessel Code

- A = ASME Pressure Vessel Code
- C = Canadian Code
- D = Australian Code
- L = Chinese Code-Imported Pressure Vessel

Digits 14,15 – Evaporator

- B1 = B1 Evaporator
- B2 = B2 Evaporator
- C1 = C1 Evaporator
- C2 = C2 Evaporator
- D1 = D1 Evaporator
- D2 = D2 Evaporator
- D3 = D3 Evaporator
- D4 = D4 Evaporator
- D5 = D5 Evaporator
- D6 = D6 Evaporator
- E1 = E1 Evaporator
- F1 = F1 Evaporator
- F2 = F2 Evaporator
- G1 = G1 Evaporator
- G2 = G2 Evaporator
- G3 = G3 Evaporator

Digit 16 – Evaporator Tube Type

- A = Enhanced fin copper (all fluids)
- W = Enhanced fin copper (water only)

Digit 17 – Evaporator Water Pass Configuration

- 2 = 2 Pass
- 3 = 3 Pass
- 4 = 4 Pass

Digit 18 – Evaporator Water Connection

- L = Left Hand
- R = Right Hand

Digit 19 – Evaporator Connection Type

- A = Standard Grooved Pipe

Digit 20 – Evaporator Water Side Pressure

- L = 150 psi (10.5 bar)
- H = 300 psi (21 bar)

Digit 21, 22 – Condenser

- B1 = B1 Condenser
- B2 = B2 Condenser
- D1 = D1 Condenser
- D2 = D2 Condenser
- E1 = E1 Condenser
- E2 = E2 Condenser
- E3 = E3 Condenser
- E4 = E4 Condenser
- E5 = E5 Condenser
- F1 = F1 Condenser
- F2 = F2 Condenser
- F3 = F3 Condenser
- G1 = G1 Condenser
- G2 = G2 Condenser
- G3 = G3 Condenser

Digit 23 – Condenser Tube Type

- A = Enhanced Fin Copper - 0.028"
- B = Smooth Bore Copper
- C = Smooth Bore CuNi
- D = Enhanced Fin Copper - 0.025"

Digit 24 – Condenser Water Passes

- 2 = 2 Pass

Digit 25 – Condenser Water Connection

- L = Left Hand
- R = Right Hand

Digit 26 – Condenser Connection Type

- A = Standard Grooved Pipe
- C = Marine
- S = Special

Digit 27 – Condenser Waterside Pressure

- L = 150 psi (10.5 bar)
- H = 300 psi (21 bar)

Digit 28 – Condenser Leaving Water Temperature

- A = Standard

Digit 29 – Refrigerant Isolation Valves

- X = No Refrigerant Isolation Valves
- V = With Refrigerant Isolation Valves

Digit 30 – Oil Cooler

- X = Without Oil Cooler
- C = With Oil Cooler

Digit 31 – Thermal Insulation

- X = No Insulation
- Q = Factory Installed Insulation

Digit 32 – Acoustic Insulation

- X = No Insulation

Digit 33 – Label and Literature Language

- C = Spanish
- E = English
- F = French

Digit 34 – Safety Devices

- X = Standard

Digit 35 – Factory Charge

- A = Factory Refrigerant Charge (R-134a)
- B = Factory Nitrogen Charge

Digit 36 – Shipping Package

- A = No Skid (Standard)
- B = Shrink Wrap
- C = Skid
- D = Skid + Shrink Wrap

Digit 37 – Flow Switch

- X = No Flow Switch
- A = Evaporator (NEMA 1)
- B = Evaporator and Condenser (NEMA 1)
- C = Evaporator (NEMA 4)
- D = Evaporator and Condenser (NEMA 4)

Model Number Descriptions

RTHDUD1F XR0UAD1W 3LAL1D2 LALAVCQA EXABXXY3 42FRXT7X XXXXVXX

Digit 38 – Factory Test

- X = Standard Test
- C = Witness Test
- D = Performance Test

Digit 39 – Starter Type

- Y = Wye-Delta Closed Transition Starter
- V = Premium AFD

Digits 40 - 42 – Design RLA (for starter)

- *** = Selection Assigned

Digit 43 – Power Line Connection Type

- A = Terminal Block
- B = Mechanical Disconnect Switch
- D = Circuit Breaker
- F = High Interrupt Circuit Breaker

Digit 44 – Max RLA (Starter)

- C = 277 max RLA (Fixed Speed)
- E = 364 max RLA (Fixed Speed)
- G = 126 max RLA (Drive and Panel)
- H = 150 max RLA (Drive and Panel)
- J = 185 max RLA (Drive and Panel)
- K = 234 max RLA (Drive and Panel)
- L = 279 max RLA (Drive and Panel)
- M = 316 max RLA (Drive and Panel)
- N = 366 max RLA (Drive and Panel)
- Q = 397 max RLA (Fixed Speed)
- R = 476 max RLA (Fixed Speed)
- T = 598 max RLA (Fixed Speed)
- U = 779 max RLA (Fixed Speed)
- V = 197 max RLA (Drive and Panel)
- W = 241 max RLA (Drive and Panel)
- X = 292 max RLA (Drive and Panel)
- Y = 367 max RLA (Drive and Panel)
- Z = 446 max RLA (Drive and Panel)
- 1 = 549 max RLA (Drive and Panel)
- 2 = 176 max RLA (Drive and Panel)
- 3 = 223 max RLA (Drive and Panel)
- 4 = 280 max RLA (Drive and Panel)
- 5 = 335 max RLA (Drive and Panel)
- 6 = 411 max RLA (Drive and Panel)
- 7 = 455 max RLA (Drive and Panel)

Digit 45 – Under/Over Voltage Protection

- X = None
- U = With Under/Over Voltage Protection

Digit 46 – Operator Interface

- T = Tracer AdaptiView™ TD7 Display

Digit 47 – Digital Communication Interface

- X = None
- 5 = LCI-C (LonTalk®) Interface
- 7 = BACnet® MS/TP
- 8 = Modbus™ Interface

Digit 48 – External Water & Current-Limit Setpoint

- X = None
- 2 = 2-10 Vdc input
- 4 = 4-20 mA input

Digit 49 – External Base Loading

- X = None
- 2 = 2-10 Vdc input
- 4 = 4-20 mA input

Digit 50 – Ice Making

- X = None
- A = Ice Making with Relay
- B = Ice Making without Relay

Digit 51 – Programmable Relays

- X = None
- R = With Programmable Relays

Digit 52 – Chilled Water Reset

- X = Chilled Water Reset - Return Water
- T = Chilled Water Reset - Outdoor Air Temperature

Digit 53 – Control Outputs

- X = None
- D = Chiller Differential Pressure & Percent RLA
- P = Condenser Pressure (% HPC) & Percent RLA
- V = Condenser Regulating Valve Control & Percent RLA

Digits 54 – Refrigerant Monitor

- Input**
- X = None
 - A = 100 ppm / 4-20 mA
 - B = 1000 ppm / 4-20 mA
 - C = 100 ppm / 2-10 Vdc
 - D = 1000 ppm / 2-10 Vdc

Digit 55 – Condenser Leaving Hot Water Temp Control

- X = None
- H = Hot Water Temp Control

Digits 56 - 58 – AFD Output

- Amps**
- 000 = Not Applicable (wye-delta starter)
 - *** = Selection Assigned (when AFD option selected)



General Data

Table 1. Nominal capacity data

Nominal Compressor	B1	B2	C1	C2	D1	D2	D3	E3
60 Hz Tonnage	175-200	200-225	225-275	275-325	325-400	375-450	n/a	n/a
50 Hz Tonnage	125-150	150-175	175-225	225-275	275-325	300-350	325-375	375-450

Notes:

1. Chiller selections can be optimized through the use of the AHRI certified TOPSS™ selection program by contacting your local Trane account manager.
2. Compressor configuration is shown in unit model number digits 6, 7.

Table 2. Water storage, refrigerant and oil charge

Unit Configuration			Evaporator Water Storage		Condenser Water Storage		Refrigerant R-134a Charge		Oil Charge ^(a)					
									Standard Units			Unit with AFD Option		
Comp ^(b)	Evap ^(c)	Cond ^(d)	gal	L	gal	L	lb	kg	Type	gal	L	Type	gal	L
B1	B1	B1	41	155	28	106	410	186		4.5	17		7.5	28.5
B1	C1	D1	55	208	31	117	490	222		4.5	17		7.5	28.5
B2	B2	B2	45	170	29	110	410	186		4.5	17		7.5	28.5
B2	C2	D2	58	220	34	129	490	222		4.5	17		7.5	28.5
C1	D6	E5	45	170	29	110	490	222		6	23		10	38
C1	D5	E4	52	197	32	121	490	222		6	23		10	38
C1	E1	F1	82	310	60	226	525	238		10	38		11	42
C2	D4	E4	52	197	32	121	490	222		6	23		10	38
C2	D3	E3	78	295	47	175	490	222		6	23		10	38
C2	F2	F3	107	405	61	231	625	284		10	38		12	45.5
D1	D1	E1	69	261	44	166	475	216	OIL048	6	23	OIL315	9.5	36
D1	F1	F2	102	386	57	216	625	284		10	38		11	42
D1 ^(e)	G1	G1	136	515	79	299	700	318		11	42		13.5	51
D1 ^(f)	G2	G2	144	545	91	344	700	318		11	42		13.5	51
D2	D2	E2	74	280	47	178	475	216		6	23		9.5	36
D2	F2	F3	107	405	61	231	625	284		10	38		11	42
D2 ^(e)	G2	G1	144	545	79	299	700	318		11	42		13.5	51
D2 ^(f)	G3	G3	159	602	97	367	700	318		11	42		13.5	51
D3/E3 ^(e)	D2	E2	74	280	47	178	475	216		6	23		9.5	36
D3/E3 ^(e)	F2	F3	107	405	61	231	625	284		10	38		11	42
D3/E3 ^(e)	G2	G1	144	545	79	299	700	318		11	42		13.5	51
E3 ^(e)	G3	G3	159	602	97	367	700	318		11	42		13.5	51

(a) If oil cooler is installed, add 0.3 gal (1L) to oil charge value given for B compressor family units. Add 1.0 gal (4L) for all other units.

(b) Unit model number digits 6, 7.

(c) Unit model number digits 14, 15.

(d) Unit model number digits 21, 22.

(e) 50 Hz units only

(f) 60 Hz units only

Table 3. Minimum/maximum evaporator flow rates – water (gpm)

Evaporator Code	Two Pass			Three Pass			Four Pass		
	Nominal Conn. Size (in.)	Min	Max	Nominal Conn. Size (in.)	Min	Max	Nominal Conn. Size (in.)	Min	Max
B1	8	253	1104	6	168	736	-	-	-
B2	8	288	1266	6	198	844	-	-	-
C1	8	320	1412	6	213	941	-	-	-
C2	8	347	1531	6	232	1022	-	-	-
D1	8	415	1812	8	275	1206	-	-	-
D2	8	450	1980	8	300	1320	-	-	-
D3	8	486	2131	8	324	1417	-	-	-
D4	8	351	1542	8	234	1028	-	-	-
D5	8	351	1542	8	234	1028	-	-	-
D6	8	293	1287	8	196	860	-	-	-
E1	8	450	1980	8	300	1320	-	-	-
F1	10	563	2478	8	376	1655	-	-	-
F2	10	604	2667	8	404	1780	-	-	-
G1	-	-	-	10	505	2218	8	379	1666
G2	-	-	-	10	550	2413	8	411	1807
G3	-	-	-	10	622	2732	8	466	2050

Notes:

1. Minimum flow rates are based on **water only**.
2. All water connections are grooved pipe.

Table 4. Minimum/maximum evaporator flow rates – water (l/s)

Evaporator Code	Two Pass			Three Pass			Four Pass		
	Nominal Conn. Size (mm)	Min	Max	Nominal Conn. Size (mm)	Min	Max	Nominal Conn. Size (mm)	Min	Max
B1	200	16	70	150	11	46	-	-	-
B2	200	18	80	150	12	53	-	-	-
C1	200	20	89	150	13	59	-	-	-
C2	200	22	97	150	15	65	-	-	-
D1	200	26	114	200	17	76	-	-	-
D2	200	28	125	200	19	83	-	-	-
D3	200	31	134	200	20	89	-	-	-
D4	200	22	97	200	15	65	-	-	-
D5	200	22	97	200	15	65	-	-	-
D6	200	18	81	200	12	54	-	-	-
E1	200	28	125	200	19	83	-	-	-
F1	250	36	156	200	24	104	-	-	-
F2	250	38	168	200	25	112	-	-	-
G1	-	-	-	250	32	140	200	24	105
G2	-	-	-	250	35	152	200	26	114
G3	-	-	-	250	39	172	200	29	129

Notes:

1. Minimum flow rates are based on **water only**.
2. All water connections are grooved pipe.

Dimensions and Weights

Figure 3. CDE, DDE, EDE configurations

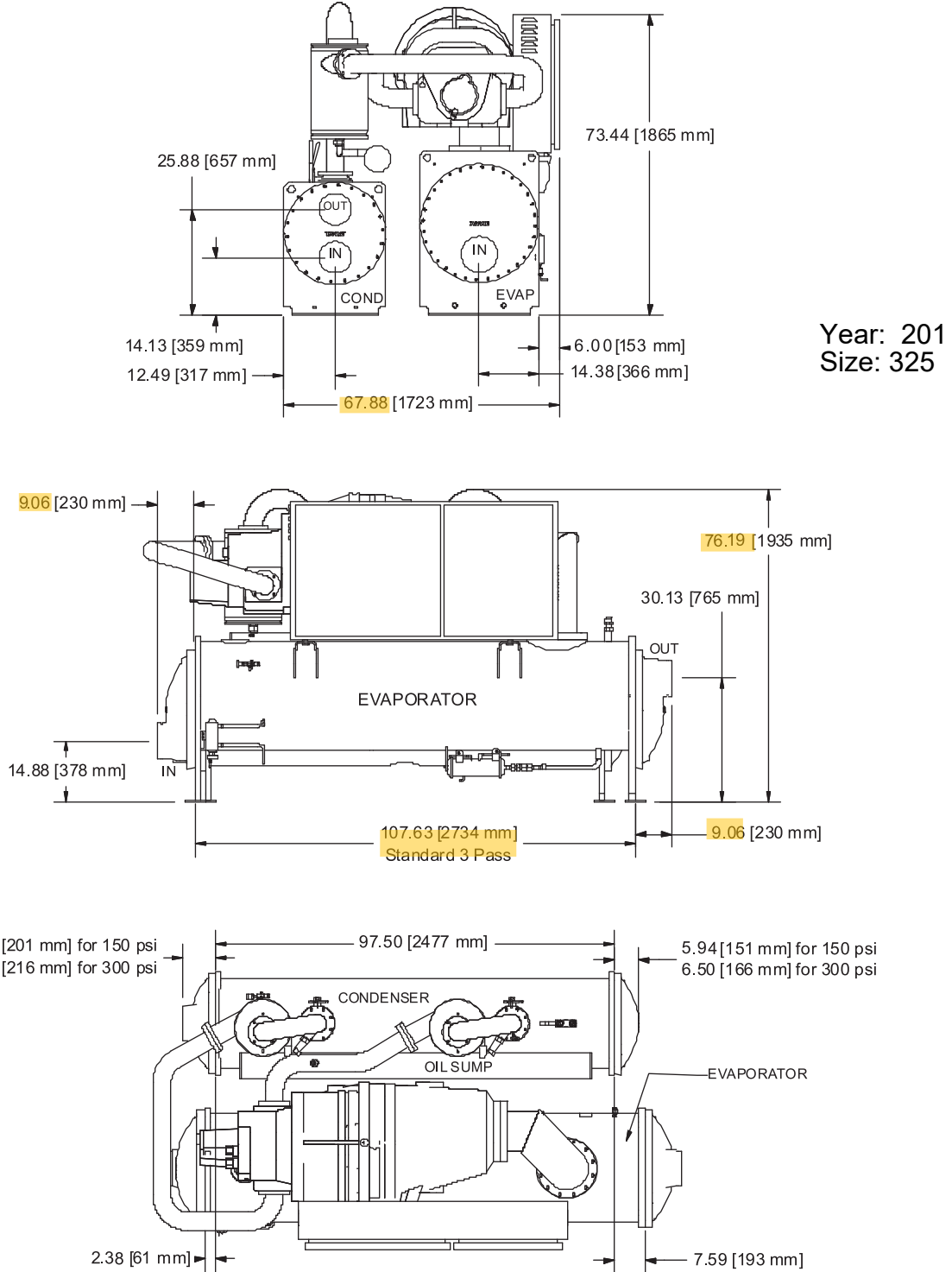



Dimensions and Weights

Weights

Table 17. Weights — standard units (wye-delta starter)

Unit Configuration ^(a)	Shipping Weight		Operating Weight	
	lbs	kg	lbs	kg
B1B1B1	9,292	4,215	9,867	4,476
B1C1D1	9,837	4,462	10,554	4,787
B2B2B2	9,402	4,265	10,019	4,545
B2C2D2	9,953	4,515	10,653	4,832
C1D5E4	12,973	5,884	13,673	6,202
C1D6E5	12,780	5,797	13,397	6,077
C1E1F1	14,718	6,676	15,818	7,175
C2D3E3	14,002	6,351	15,044	6,824
C2D4E4	12,972	5,884	13,672	6,201
C2F2F3	16,168	7,334	17,560	7,965
D1D1E1	14,443	6,551	15,385	6,987
D1F1F2	16,187	7,342	17,537	7,955
D1G1G1	18,600	8,437	20,500	9,299
D1G2G2	19,107	8,667	21,065	9,555
D2D2E2	14,562	6,605	15,570	7,062
D2F2F3	16,820	7,629	18,220	8,264
D2G2G1	18,700	8,482	20,700	9,389
D2G3G3	19,508	8,849	21,641	9,816
D3D2E2	14,562	6,605	15,570	7,062
D3F2F3	16,820	7,629	18,220	8,264
D3G2G1	18,650	8,460	20,650	9,367
E3D2E2	14,720	6,677	15,728	7,134
E3F2F3	16,956	7,691	18,356	8,326
E3G2G1	18,800	8,528	20,800	9,435
E3G3G3	19,653	8,915	21,786	9,882

Notes:

1. All weights +/- 3%
2. Shipping weights include standard 150 psig water boxes, refrigerant charge and oil charge.
3. Operating weights include refrigerant, oil and water charges.

(a) Unit configuration digits 1, 2 - compressor code (also shown in unit model number digits 6, 7); digits 3, 4 - evaporator code (unit model number digits 14, 15); digits 5, 6 - condenser code (unit model number digits 21, 22).