

Model #: ATWB12-7L12-Z
Serial #: 21P114670

Year: 2021
Size: 300 Ton



CLOSED CIRCUIT COOLERS



ATWB Coolers



Shipping Weight: 23,810 lbs.
Operating Weight: 35,690 lbs.

† Mark owned by the Cooling Technology Institute

L: 12' W: 11' 10" H: 15' 8"

THE INDUSTRY'S SMARTEST INDUCED DRAFT
Closed Circuit Cooler

ATWB 12-3J12 to 12-7N12

Selections for ATWB Closed Circuit Coolers are available from EVAPCO's SPECTRUM™ Program. Please contact your local sales representative for more information on the SPECTRUM™ program.

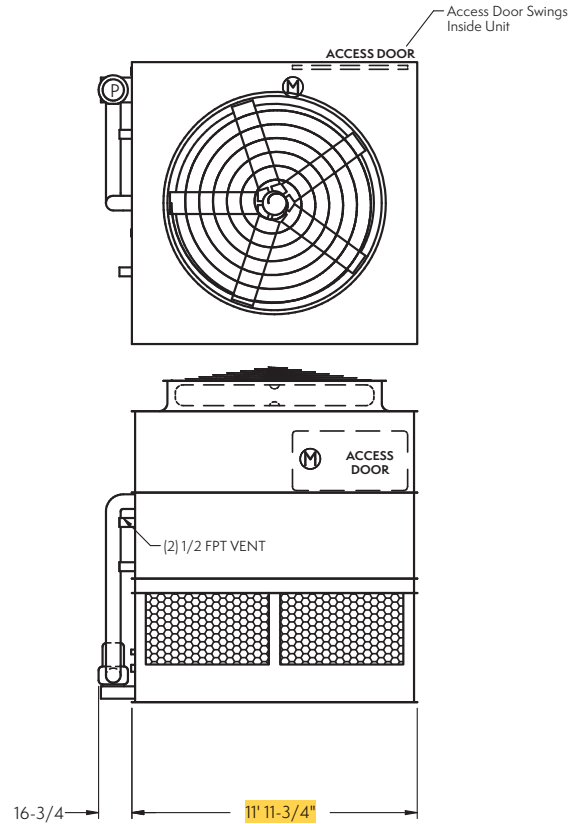
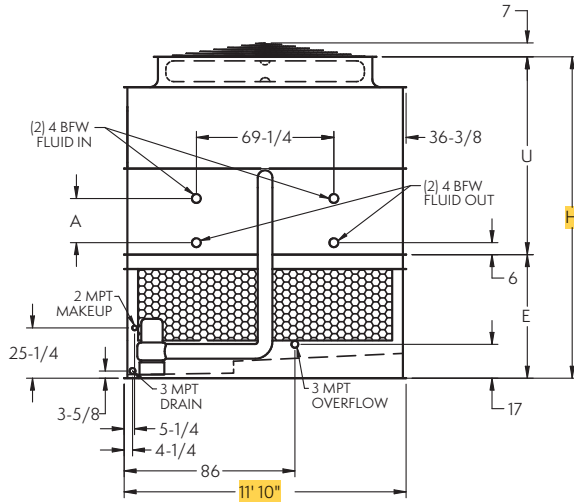

NOTE: The number of coil connections doubles when the flow rate exceeds 900 GPM on ATWB 12x12 models. This required option is referred to as the High Flow coil configuration.

ATWB Model Number†	Weights (lbs)			Fans		Spray Pump		Coil Volume (Gallons)	Remote Sump △			Dimensions ■			
	Shipping	Heaviest Section††	Operating	HP	CFM	HP	GPM		Gallons* Required	Conn. Size	Operating Weight (lbs)	Coil A	Upper U	Lower E	Height H
ATWB 12-3J12	14,250	11,540	22,870	15	72,500	5	800	312	490	12"	18,920	22-1/4"	8' 3-5/8"	5' 2-1/4"	13' 5-7/8"
ATWB 12-3K12	14,310	11,600	22,930	20	79,790	5	800	312	490	12"	18,980	22-1/4"	8' 3-5/8"	5' 2-1/4"	13' 5-7/8"
ATWB 12-3L12	14,340	11,630	22,960	25	85,040	5	800	312	490	12"	19,010	22-1/4"	8' 3-5/8"	5' 2-1/4"	13' 5-7/8"
ATWB 12-3M12	14,390	11,680	23,010	30	89,490	5	800	312	490	12"	19,060	22-1/4"	8' 3-5/8"	5' 2-1/4"	13' 5-7/8"
ATWB 12-4J12	16,560	13,850	26,000	15	70,390	5	800	409	490	12"	22,050	30-3/4"	9' 1/8"	5' 2-1/4"	14' 2-3/8"
ATWB 12-4K12	16,620	13,910	26,060	20	77,470	5	800	409	490	12"	22,110	30-3/4"	9' 1/8"	5' 2-1/4"	14' 2-3/8"
ATWB 12-4L12	16,650	13,940	26,090	25	82,560	5	800	409	490	12"	22,140	30-3/4"	9' 1/8"	5' 2-1/4"	14' 2-3/8"
ATWB 12-4M12	16,700	13,990	26,140	30	86,890	5	800	409	490	12"	22,190	30-3/4"	9' 1/8"	5' 2-1/4"	14' 2-3/8"
ATWB 12-4N12	16,860	14,150	26,300	40	94,180	5	800	409	490	12"	22,350	30-3/4"	9' 1/8"	5' 2-1/4"	14' 2-3/8"
ATWB 12-5K12	18,800	16,090	29,050	20	75,150	5	800	506	490	12"	25,100	39-1/4"	9' 8-5/8"	5' 2-1/4"	14' 10-7/8"
ATWB 12-5L12	18,830	16,120	29,080	25	80,090	5	800	506	490	12"	25,130	39-1/4"	9' 8-5/8"	5' 2-1/4"	14' 10-7/8"
ATWB 12-5M12	18,880	16,170	29,130	30	84,280	5	800	506	490	12"	25,180	39-1/4"	9' 8-5/8"	5' 2-1/4"	14' 10-7/8"
ATWB 12-5N12	19,040	16,330	29,290	40	91,350	5	800	506	490	12"	25,340	39-1/4"	9' 8-5/8"	5' 2-1/4"	14' 10-7/8"
ATWB 12-6L12	21,190	18,480	32,250	25	77,610	5	800	604	490	12"	28,300	47-3/4"	10' 5-1/8"	5' 2-1/4"	15' 7-3/8"
ATWB 12-6M12	21,240	18,530	32,300	30	81,670	5	800	604	490	12"	28,350	47-3/4"	10' 5-1/8"	5' 2-1/4"	15' 7-3/8"
ATWB 12-6N12	21,400	18,690	32,460	40	88,530	5	800	604	490	12"	28,510	47-3/4"	10' 5-1/8"	5' 2-1/4"	15' 7-3/8"
ATWB 12-7L12	23,810	21,100	35,690	25	75,130	5	800	701	490	12"	31,740	47-3/4"	10' 5-1/8"	5' 2-1/4"	15' 7-3/8"
ATWB 12-7M12	23,860	21,150	35,740	30	79,070	5	800	701	490	12"	31,790	47-3/4"	10' 5-1/8"	5' 2-1/4"	15' 7-3/8"
ATWB 12-7N12	24,020	21,310	35,900	40	85,700	5	800	701	490	12"	31,950	47-3/4"	10' 5-1/8"	5' 2-1/4"	15' 7-3/8"

† Model Numbers end in "-Z" for units with Series Flow piping configuration. Series Flow units may require additional coil connections and will require crossover piping. Model numbers will include "C" for units with Stainless Steel coil(s), "R" for units with Low Sound Fan(s) and "S" for units with an option that negates CTI certification.

†† Heaviest section is the coil/fan section.

* Gallons shown is water in suspension in unit and piping. Allow for additional water in bottom of remote sump to cover pump suction and strainer during operation (12" would normally be sufficient).

△ When a remote sump arrangement is selected, the spray pump, suction strainer and associated piping are omitted; the unit is provided with an oversized outlet to facilitate drainage to the remote sump.

■ Unit dimensions and coil connections may vary slightly from catalog. See factory certified prints for dimensions, quantity of coil connections, and piping configuration. Coil connections are 4" bevel for weld (BFW). Other connection types such as grooved for mechanical coupling or flanged are also available as options.