



Product Data

30HXA076-271 30HXC076-271 Condenserless and Fluid-Cooled Chillers 50/60 Hz

75 to 265 Tons (264 to 931 kW)

Quality Assurance



Certificate No FM 21837

Approvals:

ISO 9002

EN 29002

BS5750 PART 2

ANSI/ASQC Q92

1998

76 Ton

Model #: 30HXC076R--600AA

Serial #: 2198F45921

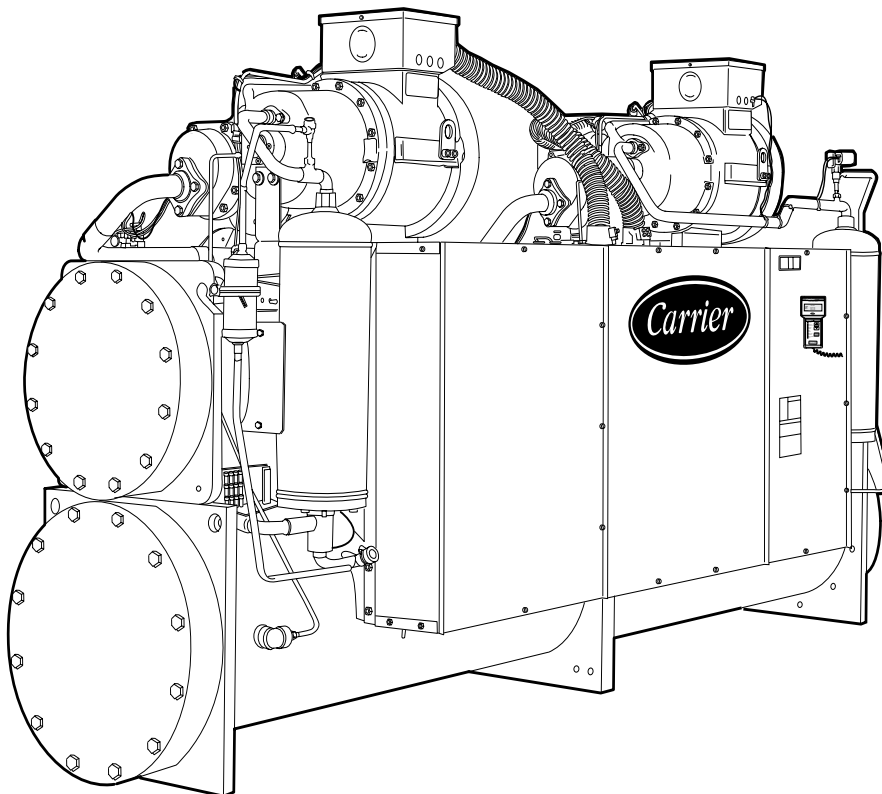

L: 11' 4"

W: 3' 11"

H: 5' 10"

Shipping Weight: 5,493 lbs

Fluid-cooled and condenserless chillers designed from the ground up to meet the needs of today and tomorrow, including:

- Fits through a standard door with no disassembly required
- Chlorine-free HFC-134a refrigerant
- Dual circuit independent refrigerant
- Smooth compression using twin screw compressors
- ARI certified efficiencies to .53 kW/ton

Features/Benefits

Quality design and construction make the 30HXC (Fluid Cooled) and the 30HXA (Condenserless) units the preferred choice

Easy installation

The 30HX chiller has a compact design that fits through a standard door opening and requires minimal indoor space. The 30HX chiller is delivered as a complete package for easy installation. There are no extra controls, clocks, starters, or other items to install.

The 30HX unit also provides a single location electrical power entrance (using the accessory field-installed control transformer) and quick, easy piping using either welded or accessory victaulic-type clamp-on couplings for the cooler.

The 30HX 208/230-v, 230-v, 460-v and 575-v units are designed in accordance with UL (Underwriters' Laboratory, U.S.A.) and CSA (Canadian Standards Association) standards to minimize electrical inspection time.

Table of contents



- Features/Benefits 1,2
- Model Number Nomenclature 3
- Physical Data 4-7
- Dimensions 8-18
- Options and Accessories 19
- Application Data 20-27
- Selection Procedure 28
- Performance Data 29-56
- Typical Piping and Wiring 57,58
- Electrical Data 59-72
- Controls 73
- Guide Specifications 74-76

Model number nomenclature

30HX C 076 R-- 600 AA

30HX C 106 --- 6 - 1 --

30HX — Indoor Liquid Chiller

Condenser Type

- A — Condenserless
- C — Fluid Cooled

Nominal Unit Size — Tons (kW)

076 — 75 (264)	161 — 155 (545)
086 — 85 (300)	171 — 165 (580)
096 — 95 (335)	186 — 175 (615)
106 — 105 (370)	206 — 211 (743)
116 — 115 (405)	246 — 246 (866)
126 — 125 (440)	261 — 255 (896)
136 — 135 (475)	271 — 265 (931)
146 — 145 (510)	

FIOPS

Contact your Carrier representative

FIOPS

Contact your Carrier representative.

Packaging

- 1 — Domestic
- 3 — Export

Not Used

Electrical Characteristics

- 1 — 575-3-60
- 2 — 380-3-60
- 4 — 230-3-60
- 5 — 208/230-3-60
- 6 — 460-3-60
- 8 — 230-3-50
- 9 — 380/415-3-50

LEGEND

FIOPS — Factory-Installed Options

Physical data



ENGLISH

UNIT SIZE 30HX	076	086	096	106	116	126	136	146
UNIT WEIGHT (lb)								
Fluid Cooled (HXC)	5700	5723	5855	6177	6415	6465	6688	6718
Condenserless (HXA)	4717	4744	4835	5151	5163	5205	5309	5333
COMPRESSORS	Semi-Hermetic, Twin Screw							
Quantity	2	2	2	2	2	2	2	2
Nominal Capacity per Compressor (tons)	39/39	46/39	56/39	66/39	66/46	66/56	80/56	80/66
Economizer	No	No	No	No	No	No	No	No
No. Capacity Steps								
Standard	6	6	6	6	6	6	6	6
Optional (maximum)	8	8	8	8	8	8	8	8
Minimum Step Capacity (%)								
Standard	20	20	20	20	20	20	20	20
Optional	10	10	10	10	10	10	10	10
REFRIGERANT	R-134a							
Charge* (lb) Circuit A/Circuit B	60/60	76/65	94/70	110/70	105/76	112/89	124/89	119/100
COOLER	Shell and Tube with Enhanced Copper Tubes							
Part No. 10HX400-	001	001	002	010	007	007	006	006
Net Fluid Volume (gal)	17.0	17.0	19.0	22.6	21.4	21.4	24.0	24.0
Maximum Refrigerant Pressure (psig)	220	220	220	220	220	220	220	220
Maximum Fluid-Side Pressure (psig)	300	300	300	300	300	300	300	300
Fluid Connections								
Inlet and Outlet (in.)	4	4	4	5	4	4	4	4
Drain (in. NPT)	1/2	1/2	1/2	1/2	1/2	1/2	1/2	1/2
Relief Valve								
Connection (in. NPTF)	3/4	3/4	3/4	3/4	3/4	3/4	3/4	3/4
Flow Capacity (lb air/min)	31.7	31.7	31.7	31.7	31.7	31.7	31.7	31.7
Relief Setting (psig)	220	220	220	220	220	220	220	220
Standard Number of Passes	3	3	3	3	2	2	2	2
30HXA OIL SEPARATOR								
Part No. 09RX400-	165	165	166	166	167	167	167	167
Maximum Refrigerant Pressure (psig)	320	320	320	320	320	320	320	320
Refrigerant Connections (in.)								
Discharge Circuit A/B	2 1/8/2 1/8	2 1/8/2 1/8	2 1/8/2 1/8	2 1/8/2 1/8	2 1/8/2 1/8	2 1/8/2 1/8	2 1/8/2 1/8	2 1/8/2 1/8
Liquid Circuit A/B	1 1/8/1 1/8	1 1/8/1 1/8	1 1/8/1 1/8	1 1/8/1 1/8	1 1/8/1 1/8	1 1/8/1 1/8	1 1/8/1 1/8	1 1/8/1 1/8
Relief Valve								
Connection (in. SAE Flare)	5/8	5/8	5/8	5/8	5/8	5/8	5/8	5/8
Flow Capacity (lb air/min)	21.6	21.6	21.6	21.6	21.6	21.6	21.6	21.6
Relief Setting (psig)	320	320	320	320	320	320	320	320
CONDENSER (HXC)	Shell and Tube with Enhanced Copper Tubes							
Part No. 09RX400-	173	173	174	174	175	175	176	176
Net Fluid Volume (gal)	16.8	16.8	18.3	18.3	23.9	23.9	27.5	27.5
Maximum Refrigerant Pressure (psig)	220	220	220	220	220	220	220	220
Maximum Water-Side Pressure (psig)	300	300	300	300	300	300	300	300
Water Connections (in.)								
Inlet and Outlet	5	5	5	5	5	5	5	5
Drain (NPT)	1/2	1/2	1/2	1/2	1/2	1/2	1/2	1/2
Relief Valve								
Connection (in. NPTF)	3/4	3/4	3/4	3/4	3/4	3/4	3/4	3/4
Flow Capacity (lb air/min)	31.7	31.7	31.7	31.7	31.7	31.7	31.7	31.7
Relief Setting (psig)	220	220	220	220	220	220	220	220
Standard Number of Passes	2	2	2	2	2	2	2	2
DISCHARGE LINE†								
Relief Valve								
Connection (in. SAE Flare)	3/8	3/8	3/8	3/8	3/8	3/8	3/8	3/8
Flow Capacity (lb air/min)	6.3	6.3	6.3	6.3	6.3	6.3	6.3	6.3
Setting (psig)	350	350	350	350	350	350	350	350

LEGEND

NPTF — National Pipe Thread Female
SAE — Society of Automotive Engineers

* Charges listed are for 30HXC units. The 30HXA units are shipped with a holding charge only. To determine the refrigerant charge requirements for 30HXA units see the System Refrigerant Charge table in the Application Data on page 26.

† Only on units with factory-installed suction service valves.

30HXC076-106

UNIT	B	C	E	L
30HXC076	45.87 (1165)	45.87 (1165)	32.50 (826)	65.22 (1657)
30HXC086	45.87 (1165)	45.87 (1165)	32.50 (826)	65.22 (1657)
30HXC096	54.12 (1375)	37.63 (956)	32.50 (826)	65.22 (1657)
30HXC106	54.12 (1375)	37.63 (956)	33.50 (851)	67.22 (1707)

- NOTES:
 1. OPERATING WEIGHT INCLUDES WEIGHT OF WATER AND REFRIGERANT.
 2. ● DENOTES CENTER OF GRAVITY.
 3. — DENOTES ACCESSORY OR FACTORY INSTALLED OPTION.
 4. DIMENSIONS ARE IN INCHES (MM) AND WEIGHTS ARE IN LB (KG).
 5. 36 IN. (914.4) RECOMMENDED SERVICE CLEARANCE AROUND MACHINE.

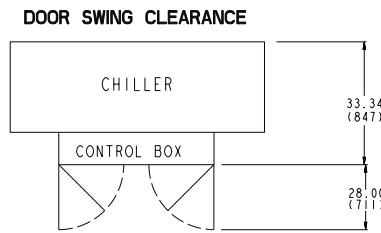
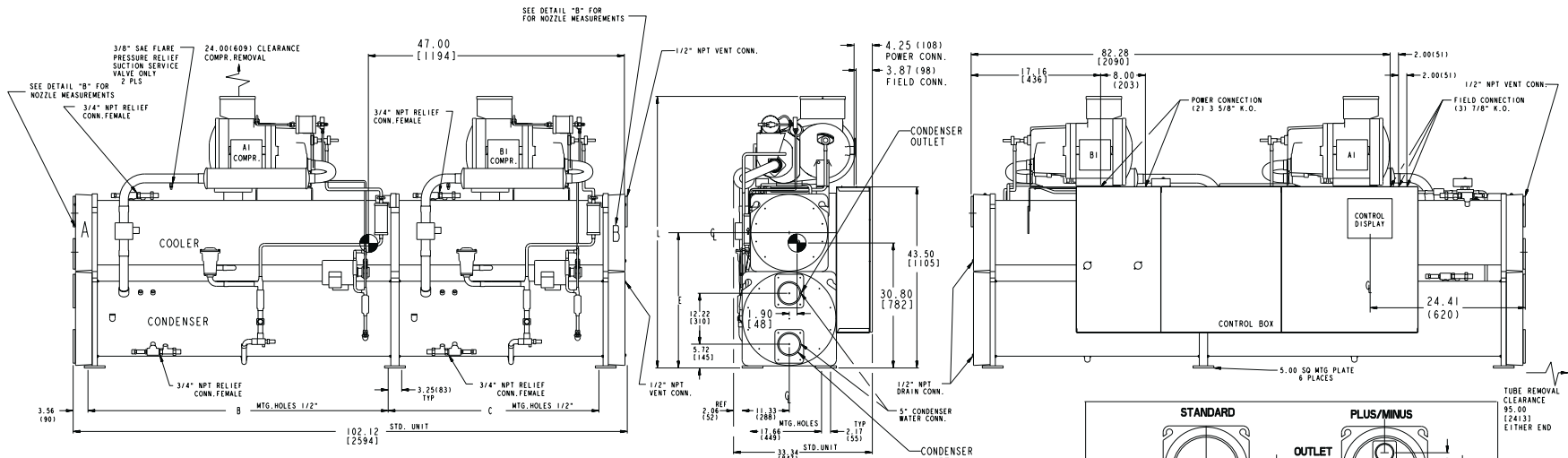

DETAIL "B"

UNIT		A	B	NUMBER OF PIPES	CONNECTION SIZES
30HXC076, 086, 096	STD	4.68 (119)	4.68 (119)	3	4"
30HXC076, 086, 096	MINUS	4.68 (119)	4.68 (119)	2	4"
30HXC076, 086, 096	PLUS	4.68 (119)	4.68 (119)	4	4"
30HXC106	STD	5.14 (131)	5.14 (131)	3	5"
30HXC106	MINUS	5.14 (131)	5.14 (131)	2	5"
30HXC106	PLUS	5.14 (131)	5.14 (131)	4	5"

TUBE REMOVAL CLEARANCE 95.00 [2413] EITHER END

