



Model #: SAD0502BG06-F4ACKB-A008AA-E10
Serial #: FF0010N264Q2496

Year: 2018
Size: 160 tons

T CLASS AIR
AIR COOLED CHILLERS
Oil-Free Centrifugal Chiller

Shipping Weight: 11,563 lbs
Operating Weight: 11,938 lbs

L: 15' 11"
W: 7' 7"
H: 9'

SMARTD

PHYSICAL DATA

SMARTD

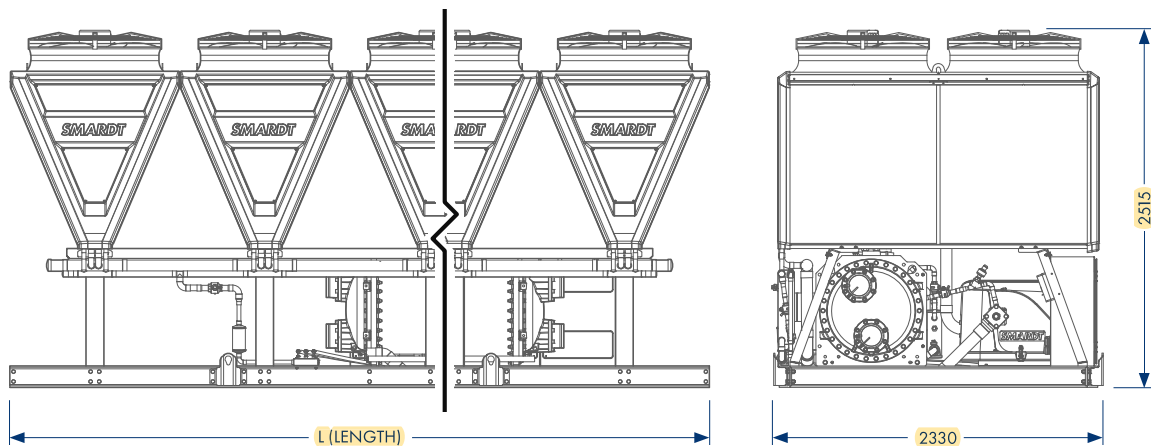

BASE MODEL	FAN QTY	OVERALL LENGTH 'L' (mm)	OPERATING WEIGHT (kg)	SHIPPING WEIGHT (kg)
ADO28.1B	4	2400	3205	3080
	6	3600	3765	3645
ADO40.1E	6	3600	4305	4135
	8	4800	4870	4700
	10	6000	5515	5345
ADO54.2B	8	4800	5415	5245
	10	6000	6060	5890
	12	7200	6620	6450
ADO65.2E	10	6000	6535	6315
	12	7200	7095	6880
	14	8400	7660	7445
ADO80.2E	12	7200	7240	7005
	14	8400	7800	7570
	16	9600	8365	8130
ADO86.3B	12	7200	7700	7435
	14	8400	8265	8000
	16	9600	8825	8560
AD110.4B*	16 (8+8)	9600 (4800+4800)	10790 (5505+5285)	10435 (5320+5115)
	20 (10+10)	12000 (6000+6000)	11920 (6635+6415)	11565 (6450+6245)
	24 (12+12)	14400 (7200+7200)	13050 (7765+7545)	12695 (7580+7375)
AD120.3E	16	9600	9475	9150
	18	10800	10040	9715
AD150.4E*	20 (10+10)	12000 (6000+6000)	12980 (6555+6425)	12480 (6305+6175)
	24 (12+12)	14400 (7200+7200)	14110 (7685+7555)	13610 (7435+7305)
	28 (14+14)	16800 (8400+8400)	15240 (8815+8685)	14740 (8565+8435)
AD160.4E*	24 (12+12)	14400 (7200+7200)	14440 (7285+7155)	13920 (7025+6895)
	28 (14+14)	16800 (8400+8400)	15570 (8415+8285)	15050 (8155+8025)
	32 (16+16)	19200 (9600+9600)	16700 (9545+9415)	16180 (9285+9155)

* Dual circuit chillers, shipped in two sections.