

Model #: YKK8K3H9-CUG
Serial #: SNXM-143960

FORM 160.75-EG1 (1011)



2011
800 Tons

BY JOHNSON CONTROLS

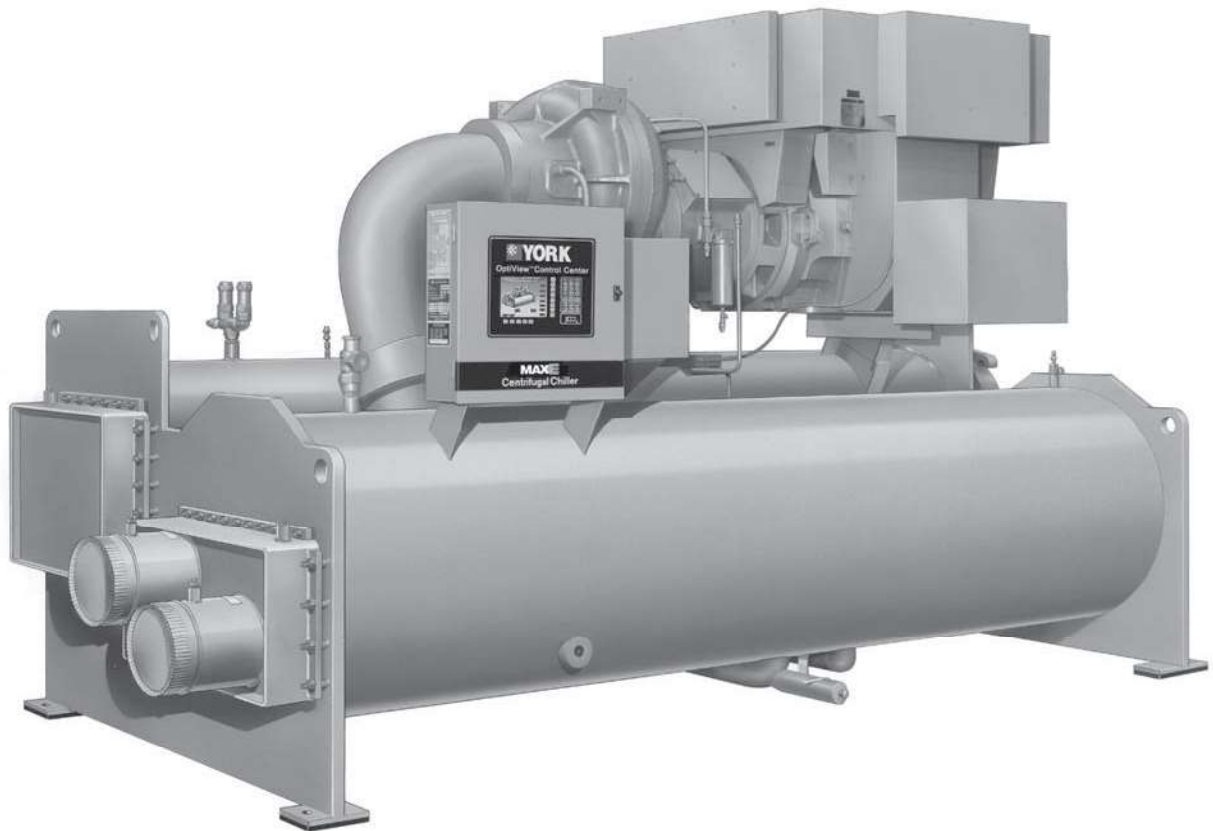

***Model YK Centrifugal Liquid Chillers
Design Level G***

L: 16' 6"
W: 8' 4"
H: 9' 7"

Shipping Weight: 28,530 lbs
Operating Weight: 36,000 lbs

250 THROUGH 3000 TONS
(879 through 10,500 kW)
Utilizing HFC-134a
Heat Recovery
Flooded Evaporator & Hybrid Falling Film Evaporator

Table of Contents

FORM 160.75-EG1 (1011) 1

Introduction..... 3

Ratings 4

Sustainability Focus..... 5

OptiView Control Center 7

Mechanical Specifications..... 15

Accessories and Modifications..... 20

Application Data 27

Dimensions (Ft. - In.) - Unit..... 48

Dimensions (Ft. - In.) - Nozzle Arrangements 51

Weights - English 62

Dimensions (mm) - Unit..... 64

Dimensions (mm) - Nozzle Arrangements..... 66

Weights - SI..... 78

Guide Specifications..... 80

SI Metric Conversion..... 87

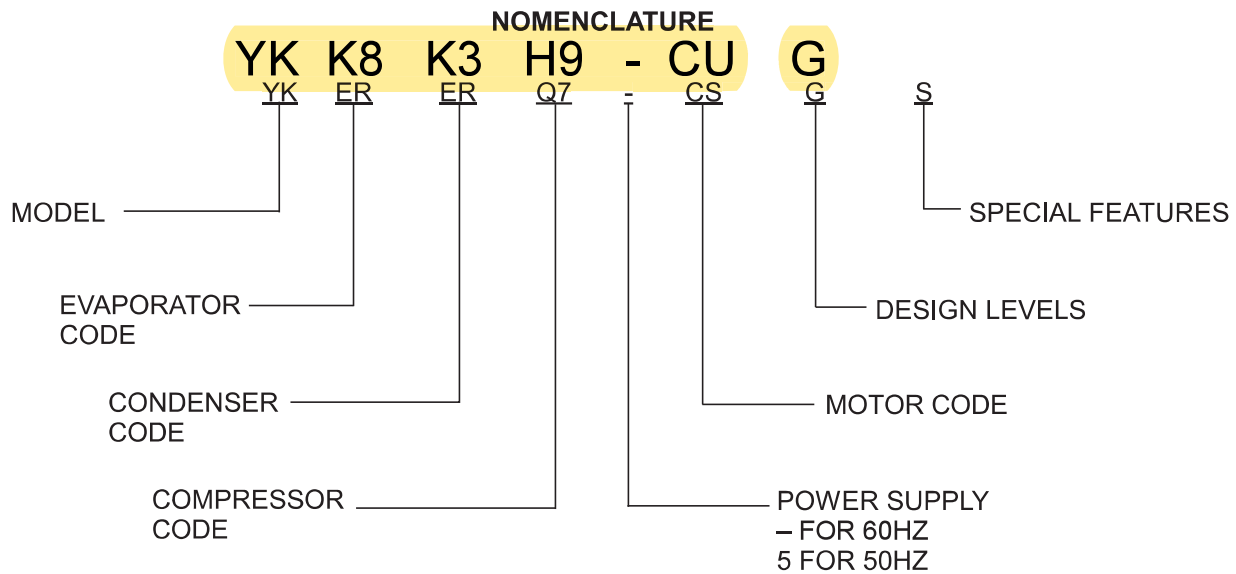

H COMPRESSOR UNITS

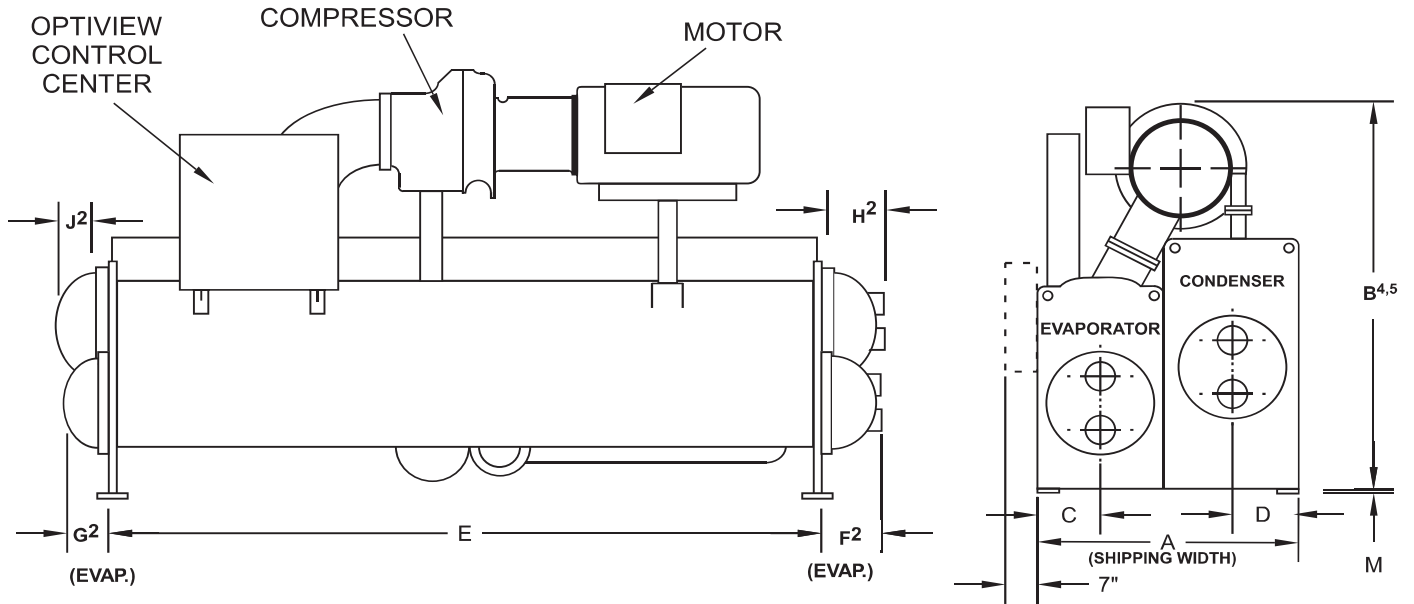

ADDITIONAL OPERATING HEIGHT CLEARANCE

TYPE OF CHILLER MOUNTING	M
NEOPRENE PAD ISOLATORS	1-3/4"
SPRING ISOLATORS 1" DEFLECTION	1"
DIRECT MOUNT	3/4"

H9 COMPRESSORS

EVAP.-COND. SHELL CODES

	K-K	K-O	M-M
A	7'-6 1/2"	8'-9 1/4"	8'-7"
B	10'-4"	10'-7 5/8"	10'-10 1/2"
C	2'-1 1/4"	2'-1 1/4"	2'-4 1/2"
D	1'-8"	2'-3 3/8"	1'-11"
E	14'-0"	14'-0"	14'-0"

NOTES:

1. All dimensions are approximate. Certified dimensions are available on request.
2. For all waterboxes (compact shown above), determine overall unit length by adding waterbox depth to tube sheet length.
3. Water nozzles can be located on either end of unit. Add 1/2" to nozzle length for flanged connections.
4. To determine overall height, add dimension "M" for the appropriate isolator type.
5. Use of motors with motor hoods may increase overall unit dimensions.

Weights - English

TABLE 19 – APPROXIMATE UNIT WEIGHT INCLUDING MOTOR²

SHELLS	COMPRESSOR	SHIPPING WEIGHT (LBS.)	OPERATING WEIGHT (LBS.)	EST. REFRIGERANT CHARGE (LBS.) ¹
A-A	Q3	13,100	15,000	828
C-B	Q4	18,023	22,323	1,525
C-C	Q3, Q4	14,920	17,940	1,221
C-C	Q5	15,330	18,350	1,221
D-D	Q3, Q4	17,215	21,100	1,628
D-D	Q5	17,625	21,510	1,628
E-E	Q3, Q4	17,950	22,160	1,710
E-E	Q5,Q6,Q7,P7	18,360	22,570	1,710
E-I	Q7	23,567	29,384	1,805
F-F	Q5,Q6,Q7,P7	18,720	23,880	2,175
G-E	P8	20,300	24,200	1,990
H-F	P8,P9	23,100	28,000	2,610
J-J	P8,P9	24,000	29,100	2,550
L-L	P8,P9	27,400	33,900	3,165
K-K	H9	28,530	36,000	2,925
K-K	K1	31,100	36,200	3,248
K-O	H9	34,483	44,776	3,260
M-M	H9	34,200	43,600	3,665
M-M	K1,K2	38,300	47,100	3,665
M-U	K2	45,178	58,017	3,540
N-N	K1,K2	40,893	50,800	4,225
N-N	K3	48,000	54,100	4,225
P-P	K1,K2	41,500	51,900	3,855
Q-Q	K1,K2	45,300	56,800	4,255
Q-Q	K3	46,000	60,200	4,255
R-R	K3	52,800	70,300	4,600
R-R	K4	53,000	70,600	4,600
S-S	K4	59,000	76,300	4,815
S-V	K4	60,100	81,300	5,467
X-T	K4	59,200	80,000	5,338
X-X	K4	66,000	87,000	5,875
W-W	K7	79,500	104,000	8,002
Z-Y	K7	95,230	123,015	7,175
Z-Z	K7	80,500	105,000	6,984

¹ Refrigerant charge quantity and weights will vary based on tube count.

² Refer to product drawings for detailed weight information.

TABLE 20 – APPROXIMATE UNIT WEIGHT INCLUDING MOTOR

UNIT WITH HYBRID FALLING FILM EVAPORATOR				
SHELLS	COMPRESSOR	SHIPPING WEIGHT (LBS.)	OPERATING WEIGHT (LBS.)	EST. REFRIGERANT CHARGE (LBS.) ¹
A-A	Q3	12,850	14,419	695
C-C	Q3, Q4	14,570	16,848	875
C-C	Q5	15,000	17,278	875
D-D	Q4	17,000	20,051	1,180
D-D	Q5	17,410	20,461	1,180
E-E	Q5,Q6,Q7,P7	18,700	21,700	1,120
F-F	Q5,Q6,Q7,P7	19,220	23,142	1,415
G-E	P8, P9	20,640	24,036	1,320
H-F	P8, P9	23,540	28,083	1,775
K-K	H9	28,850	34,079	1,820

¹ Refrigerant charge quantity and weights will vary based on tube count and configuration. Use for reference only.