

Model #: YSDACBS3-CJES
Serial #: SHXM-865600

FORM 160.80-EG1 (511)

2011
245 Tons



BY JOHNSON CONTROLS



L: 12' 9"
W: 6' 1"
H: 6' 9"

Shipping Weight: 15,740 lbs
Operating Weight: 17,911 lbs

*Model YS Rotary Screw Liquid Chillers
Design Level E*



100 thru 675 tons
(315 thru 2375 KW)
R-134



Products are produced at a facility whose quality-management systems are ISO9001 certified.

Contents

FORM 160.80-EG1 (511) 1

Introduction..... 3

Ratings 4

OptiView Control Center 5

Mechanical Specifications..... 13

Accessories and Modifications..... 18

Unit Components..... 20

Application Data 22

Dimensions - Std 30

Dimensions - Std..... 34

Weights - Std..... 38

Dimensions - Metric 40

Weights - Metric..... 48

Guide Specifications 50

Metric Conversion Tables..... 56

NOMENCLATURE

The model number denotes the following characteristics of the unit:

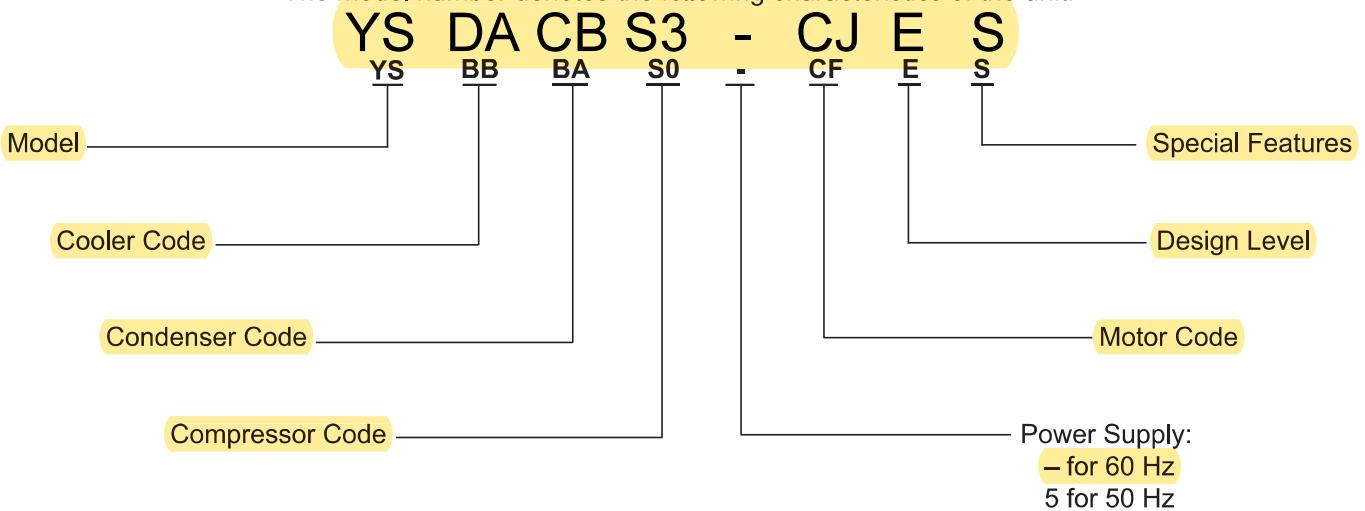

S0 - S3 COMPRESSOR R-134a UNITS (50 and 60 Hz)

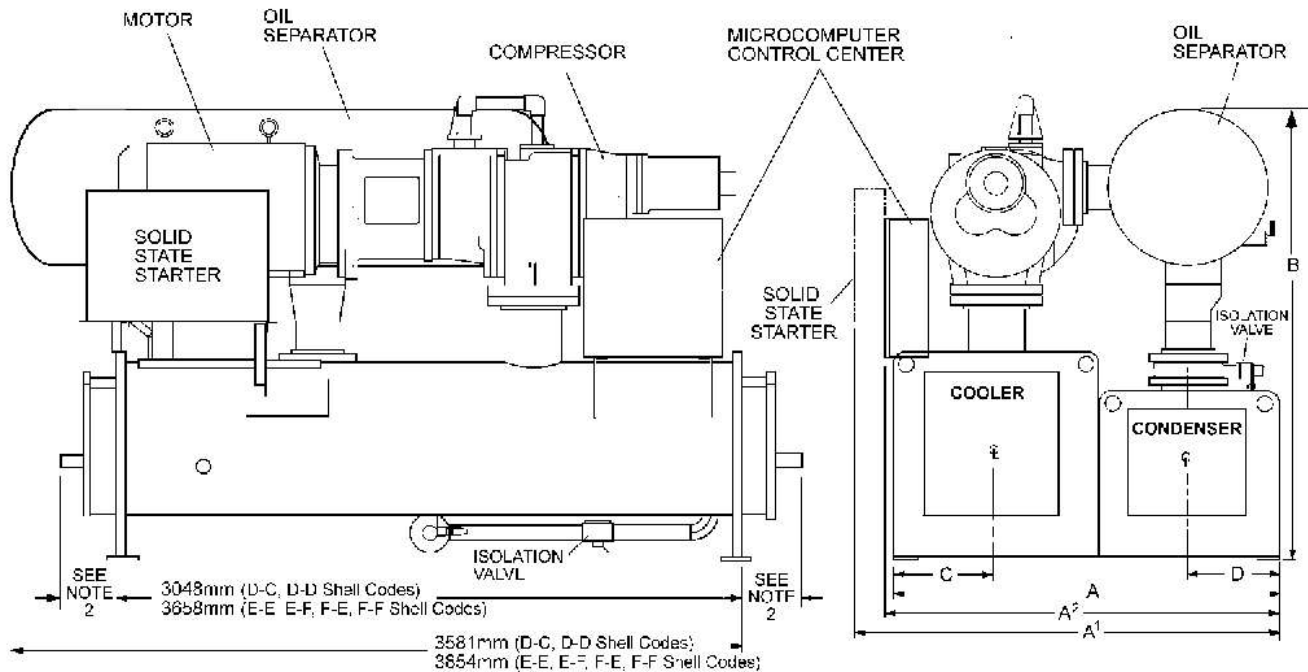

DIMENSION	S0 and S1 COMPRESSOR				S2 COMPRESSOR			S2 and S3 COMPRESSOR			
	SHELL CODES (Evaporator - Condenser)										
	B-B	B-C	C-B	C-C	B-B	B-C	C-B	C-C	C-D	D-C	D-D
A	4'-2-7/8"				5'-2-1/2"			5'-2-1/2"			
A ¹	4'-6-3/4"	4'-6-1/4"	4'-6-3/4"	4'-6-1/4"	5'-3-3/4"			5'-3-3/4"			
B - OVERALL HEIGHT ³	5'-8-5/8"	5'-11-1/2"	5'-10-1/4"	5'-11-1/2"	5'-11-1/4"	6'-3-1/4"	6'-3-1/4"	6'-3-1/4"	6'-7-5/8"	6'-8-3/4"	6'-9-3/8"
C - COOLER C/L	1'-1-7/8"				1'-5"			1'-5"			
D - CONDENSER C/L	0'-11-5/8"				1'-2-1/4"			1'-2-1/4"			

Refer to Tables 6 and 7 on pages 26 & 27 for valid compressor/shell/motor combinations.

REFRIGERANT RELIEF VALVE CONNECTIONS

SHELL CODE	EVAPORATOR SIZE	CONDENSER SIZE
B, C	3/4" FPT SINGLE	3/4" FPT DUAL
D	1" FPT SINGLE	3/4" FPT DUAL

NOTES:

- All dimensions are approximate. Certified dimensions are available on request.
- Determine overall unit length by adding water box dimension to tube sheet length:
 5-1/4" for compact return box
 14" for compact water box with ANSI/AWWA C-606 couplings water nozzles
 Add 1/2" to each compact water box with optional flanged water nozzles
- Unit height includes steel mounting plates under tube sheets. To determine overall height, add 7/8" for neoprene isolators (1" for optional spring isolators).