



Installation Operation Maintenance

RMWE-IOM-1A

Library	Service Literature
Product Section	Commercial Aftermarket Products
Product	Refrigerant Monitor
Model	RMWE
Literature Type	Installation/Operation/Maintenance
Sequence	1A
Date	November 1998
File No.	SV-CAP-RM-RMWE-IOM-1A-1198
Supersedes	RMWE-IOM-1

Trane[®] TruSense[™] MG Refrigerant Monitor

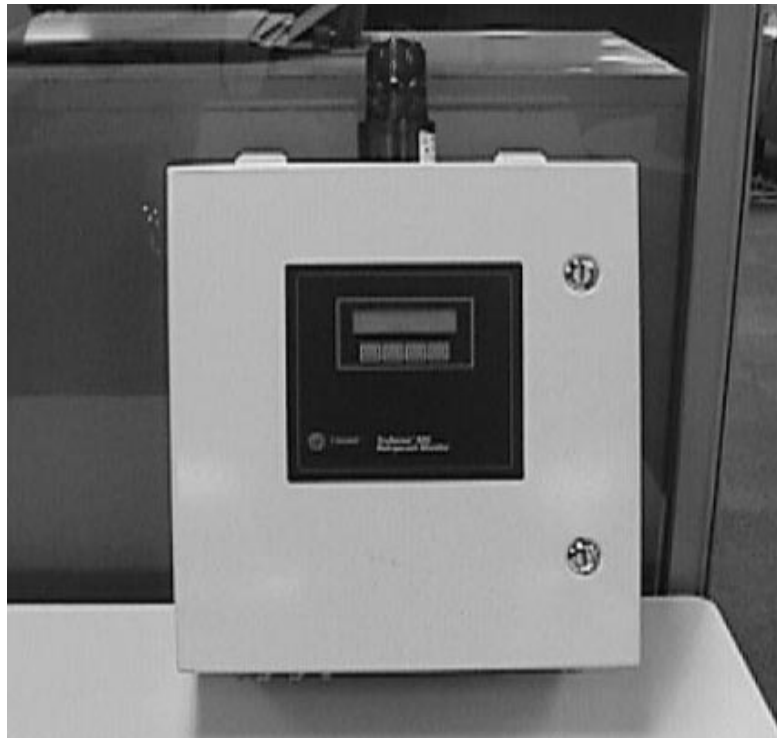

Since The Trane Company has a policy of continuous product improvement, it reserves the right to change specifications and design without notice. The installation and servicing of the equipment referred to in this booklet should be done by qualified, experienced technicians.

Table of Contents



WARNING

This manual, including the warnings and cautions inside, must be carefully read and followed by all persons who use or maintain this product, including those who have any responsibility involving its selection, application, service or repair. This monitor will perform as designed only if used and maintained according to the instructions. Otherwise, it could fail to perform as designed and persons who rely on this product could sustain serious personal injury or death.

Page	Description	Page	Description	Page	Description
3	Model Number and Nameplates	12	Electrical Connections		
4	General Information	12	— Unit Power Wiring	28	—Analog Outputs
4	Literature Change History	13	— Alarm Relay Wiring	29	Diagnostics Screens
4	Receiving	13	— Analog Output Wiring	30	Data Screens
4	Unpacking	14	— Remote Alarm Reset	31	— Remote Alarm Reset
4	Warnings and Cautions	14	— Auxiliary Input	31	— Audible Alarm Output
6	Unit Description	16	Operation	32	— Auxiliary Input
6	—Clear Language Display	17	Display Screen Overview	33	— Monitor Cross-Sensitivity
7	Installation	19	Calibration Screens	34	Calibration
7	Location of the Unit	21	Setup Screens	34	Material Required
7	— Locating the Monitor	22	— Sequencer	35	Preparing for Calibration
7	— Locating the Sensing Point(s)	23	— Alarm Levels	35	Zero Calibration Check
8	— Room Configuration	25	— Alarm Relays	36	Refrigerant Span Calibration Check
8	— Airflow Patterns	26	— Audio Alarm	40	Troubleshooting
8	— Equipment Configuration	26	— Auxiliary Alarm	44	Technical Specifications
8	— Activity in the Room			44	Mechanical
9	Mounting			44	Electrical
10	— Sample Tubing Installation			45	Gas Sensing Characteristics
10	— Exhaust Tubing Installation			46	Agency Listing

Page	List of Figures Description	Page	List of Figures Description
4	Figure 1 Typical Unit Nameplate Data	38	Figure 32 Gas by Point Setup Screen
7	Figure 2 Typical Infrared Photoacoustic Setup	39	Figure 33-34 Alarm Level Screen
8	Figure 3 Typical RMWE Installation	43	Figure 35a-c Channel Modes
10	Figure 4 Physical Data		
11	Figure 5 Typical Filter Installation		
12	Figure 6 Electrical Connections		
13	Figure 7 Fuse Locations		
13	Figure 8 Power Connections		
17	Figure 9 Display Screen Overview	35	Table 1 Zero Calibration Procedure
18	Figure 10 Start-Up and Operation Screens		
19,20	Figure 11-13 Calibration		
21-28	Figure 14-23 Setup Menu		
29,30	Figure 24-27 Information Menu		
32	Figure 28 Auxiliary Alarm Example		
34	Figure 29 Various Sample Inlet Views		
36	Figure 30 Zero Calibration Check Connections		
36	Figure 31 Calibration Check Connections		

Model Number and Nameplates

Unit Model Number

For service and replacement purposes, the Trane Model RMWE Refrigerant Monitor is assigned a multiple-character alphanumeric model number that precisely

identifies each unit. The model number key is shown here.

Use of the model number will enable the owner/operator, installing contractor, and service technician to

define the characteristics of any RMWE unit. Be sure to refer to the model number when ordering replacement parts or requesting service.

Sample Model Number

Model No.	R	M	W	E	R	P	1	0	0	A	0	0	0	0	A	A	0	0	0	0	0	0	0	0
Digit No.	1, 2	3	4	5	6	7	8	9	10	11	12	13	14	15	16,17	18,19	20,21	22,23	24,25	26,27				
Digits 1,2	Product Description		Digit 14		Digits 18,19		Digits 20,21		Digits 22,23		Digits 24,25		Digits 26,27											
	RM = Refrigerant Monitor		Auxiliary Sensor		Refrigerant Type		Refrigerant Type		Refrigerant Type		Refrigerant Type		Refrigerant Type											
			0 = None		00 = None		00 = None		00 = None		00 = None		00 = None											
Digit 3			1 = Oxygen, 0-25%		AB = R-123		AB = R-123		AB = R-123		AB = R-123		AB = R-123											
Mounting Configuration			2 = Oxygen, 0-5%		AC = R-11		AC = R-11		AC = R-11		AC = R-11		AC = R-11											
U = Unit Mount			3 = Carbon Monoxide, 0-100 PPM		AD = R-22		AD = R-22		AD = R-22		AD = R-22		AD = R-22											
W = Wall Mount			4 = Carbon Monoxide 0-500 PPM		AE = R-134A		AE = R-134A		AE = R-134A		AE = R-134A		AE = R-134A											
Digit 4					AF = R-12		AF = R-12		AF = R-12		AF = R-12		AF = R-12											
Development Sequence					AG = R-113		AG = R-113		AG = R-113		AG = R-113		AG = R-113											
E = 4th					AH = R-114		AH = R-114		AH = R-114		AH = R-114		AH = R-114											
Digit 5					AJ = R-500		AJ = R-500		AJ = R-500		AJ = R-500		AJ = R-500											
Monitor Type					AK = R-502		AK = R-502		AK = R-502		AK = R-502		AK = R-502											
R = Refrigerant Specific, Single Gas					AL = R-507		AL = R-507		AL = R-507		AL = R-507		AL = R-507											
M = Multiple Gas					AM = R-508B		AM = R-508B		AM = R-508B		AM = R-508B		AM = R-508B											
Digit 6					AN = R-401A		AN = R-401A		AN = R-401A		AN = R-401A		AN = R-401A											
Flow Bench Type					AP = R-402A		AP = R-402A		AP = R-402A		AP = R-402A		AP = R-402A											
P = Pump					AR = R-404A		AR = R-404A		AR = R-404A		AR = R-404A		AR = R-404A											
D = Diffusion					AT = R-407C		AT = R-407C		AT = R-407C		AT = R-407C		AT = R-407C											
Digit 7					AU = R-141B		AU = R-141B		AU = R-141B		AU = R-141B		AU = R-141B											
Sample Points					AV = R-142B		AV = R-142B		AV = R-142B		AV = R-142B		AV = R-142B											
1 = Single Point					AW = R-143B		AW = R-143B		AW = R-143B		AW = R-143B		AW = R-143B											
4 = Four Points					AX = R-152A		AX = R-152A		AX = R-152A		AX = R-152A		AX = R-152A											
8 = Eight Points					AY = R-13		AY = R-13		AY = R-13		AY = R-13		AY = R-13											
Digit 8					AZ = R-125		AZ = R-125		AZ = R-125		AZ = R-125		AZ = R-125											
Voltage					BA = R-124		BA = R-124		BA = R-124		BA = R-124		BA = R-124											
1=100-240 Volts, 50/60 Hz																								
Digit 9																								
Display Options																								
0 = UCP2 Communicaton																								
1 = Human Interface																								
Digits 10,11																								
Design Sequence																								
A0 = First Design Sequence																								
Digit 12																								
Alarm Options																								
0 = None																								
1 = Unit Mounted Beacon																								
Digit 13																								
Not Used																								

Model Number and Nameplates

Nameplates

The Model RMWE unit nameplate is located on the right side of the monitor (when facing the front). The nameplate includes the service model number, unit serial number and electrical information. Refer to this information whenever making inquiries or ordering replacement parts. A typical nameplate is shown in Figure 1.

Figure 1
Typical Unit Nameplate Data

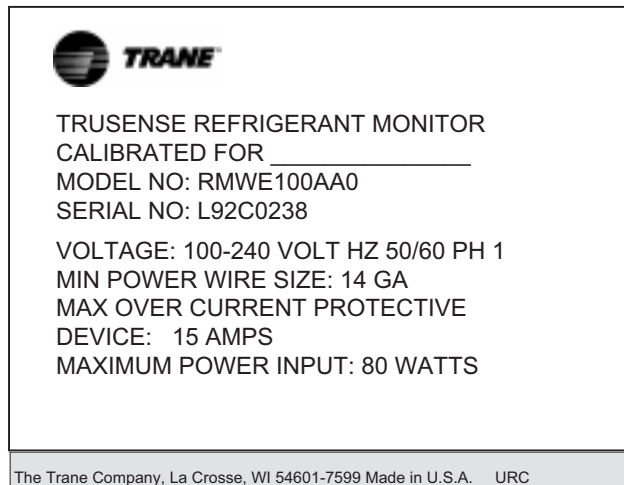

General Information

Literature Change History

RMWE-IOM-1 (July 1998)

Original issue of the manual pertaining to design sequence A0.

RMWE-IOM-1A (November 1998)

Updates on UL requirements

Receiving

Upon receipt of the unit, inspect the shipping carton for signs of visible damage. Report any damage to the carrier and note it on the delivery receipt. Unit must be stored in a dry, secure place prior to its installation and use. Store in the original shipping carton.

Unpacking

Carefully remove the monitor from the shipping container. Inspect it for signs of visible shipping damage. If any damage is found, report it to the shipper immediately. Do not install or operate a damaged unit without sales office approval.

Confirm all the loose items shipped with the monitor have been received. Each carton should contain:

Qty Item

- (1) Refrigerant Monitor
- (1) Particle Filter (3 or 7 additional filters if 4 or 8 point monitor is ordered)
- (1) Installation, Operation and Maintenance manual
- (1) **Optional** Unit Mounted Beacon

Note: The particle filter(s), fuses and the jumper are shipped in a small box inside the main monitor shipping carton. Make sure it does not get discarded or lost.

Report any shortages immediately to the local Trane office. Retain the original packing for re-use in the event the unit must ever be returned for service.

Warnings and Cautions

Warnings and Cautions appear at appropriate sections throughout this manual.

WARNINGS

alert the installer, owner, operator or service personnel to potential hazards that, if not avoided, could result in death or serious personal injury.

CAUTIONS

are provided to alert personnel to conditions which, if not avoided, may result in minor or moderate injury. It may also alert against unsafe practice causing damage to equipment.

General Information

Unit Description

The Trane Model RMWE Refrigerant Monitor circulates room air through a sensing cell to provide a continuous indication of refrigerant vapor concentration. It is intended for indoor use in mechanical equipment rooms which house air conditioning or refrigeration equipment or in areas where bulk refrigerants are stored. The monitor utilizes infra-red photo-acoustic sensing technology, allowing accurate measurement of refrigerant vapors with minimum interference from other chemicals in the vicinity. The instrument is compound-specific and factory calibrated for the specific refrigerant of interest. It is capable of measuring down to 1 ppm and displaying refrigerant concentrations from 0-1,000 parts-per-million (ppm). The monitor can signal alarms at three different concentration levels. These alarms are factory set, but can be easily adjusted in the field. A unit trouble alarm indicates internal problems with the instrument. A level alarm or a trouble alarm condition will cause the display to flash with a diagnostic message and activate a dry contact relay(s) which can be used to control external alarm lights or horns, start emergency ventilation, or signal a building management system. The refrigerant level alarm relays can be configured as latching or non-latching. 0-10 VDC and 4-20 mA analog outputs are provided for connection to a data recorder or building management system. These analog outputs can be scaled as 0-100 ppm or 0-1000 ppm. The standard unit monitors one zone. The optional multi-channel scanner can be factory or field installed to monitor up to four or eight zones.

Clear Language Display (CLD)

All setup, alarm, diagnostic, measured concentration and calibration information for the monitor is accessed through the clear language display (CLD) mounted in the unit front panel.

General Information

Infrared Photoacoustics

Increased industrialization together with a growing concern for human safety and the environment have stimulated the demand for sensitive and reliable methods of detecting trace amounts of gases. The advantages of infrared photoacoustic gas detection, which the Trane Model RMWE refrigerant monitor uses, include greater sensitivity, high immunity to interferences, fast response time and low maintenance.

The Trane Model RMWE refrigerant monitor detects toxic gases by a process called infrared photoacoustic spectroscopy. The photoacoustic effect is the emission of sound by an enclosed sample on the absorption of pulsed infrared light.

Portions of the Infrared Photoacoustics section reprinted with permission from Bruel and Kjaer Instruments, Inc.

When a gas is irradiated with light, it absorbs some of the incident light energy, proportional to the concentration of the gas. The absorbed light energy is immediately released as heat and this causes the pressure to rise. When the incident light is modulated at a given frequency, the pressure increase is periodic at the modulation frequency. Pressure waves, or sound waves as they are commonly known, are easily measured with a microphone. They are audible if their frequency is between 20 Hz and 20 kHz.

The intensity of the sound emitted depends on the nature and concentration of the substance and the intensity of the incident light.

The selectivity which can be achieved in spectroscopy is due to the fact that substances absorb light of specific wavelengths which are characteristic of that substance.

The sequence of events in this process are:

- | gas sample is sealed in measurement chamber
- | chamber is irradiated with pulsed, narrow-band light
- | gas absorbs light proportional to its concentration and converts it to heat
- | gas heats and cools as the light is pulsed
- | temperature fluctuations generate pressure waves,
- | pressure waves are detected by microphone

The main parts of a photoacoustic set-up (see Figure 2) are a chamber to contain the gas sample, a pulsing light source, a detector to measure the sound (usually a microphone) and a method of processing the signal. The signal is interpreted by the electrical components into a parts per million (ppm) display.

Figure 2—Typical Infrared Photoacoustic Setup

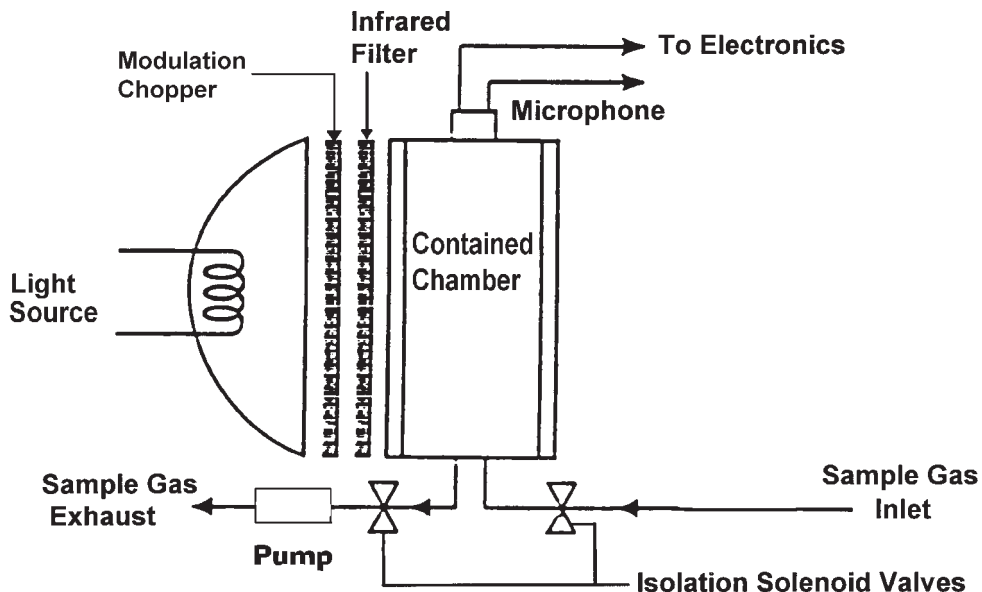

Installation

Location of the Unit

The ability of the monitor to properly measure and display the refrigerant concentration is dependent on the location of the monitor and the sensing pick-up point(s).

Locating the Monitor

Items to consider in locating the Refrigerant Monitor include:

- I Mount the unit in a location where it will be free from shock and vibration. Avoid mounting to piping or piping supports which may transmit vibration from pumps, chillers, etc.
- I Mount the unit so the front panel display can be easily viewed.
- I Do not locate the unit near an excessive heat source or in direct sunlight. Mount in an area of stable temperature and humidity conditions.

- I Unit must be mounted in a vertical position.
- I Locate in an area where it can be easily accessed for service and calibration.

Locating the Sensing Point(s)

Due to the wide variation in equipment room layouts, each situation must be analyzed individually. A sensing point may be remotely located up to 150 feet using 1/4" OD, 1/8" ID copper tube or up to 500 feet using 1/4" OD, 3/16" ID copper tube from the monitor. The sensing point should be positioned 12 to 18 inches above the floor in an area where refrigerant vapors are most likely to accumulate.

Note: The 150 and 500 feet distances refer to the total sample and exhaust line length for each sample point.

The following items should be considered when selecting the location for the refrigerant pick-up point(s).

Figure 3
Typical RMWE Refrigerant Monitor Installation

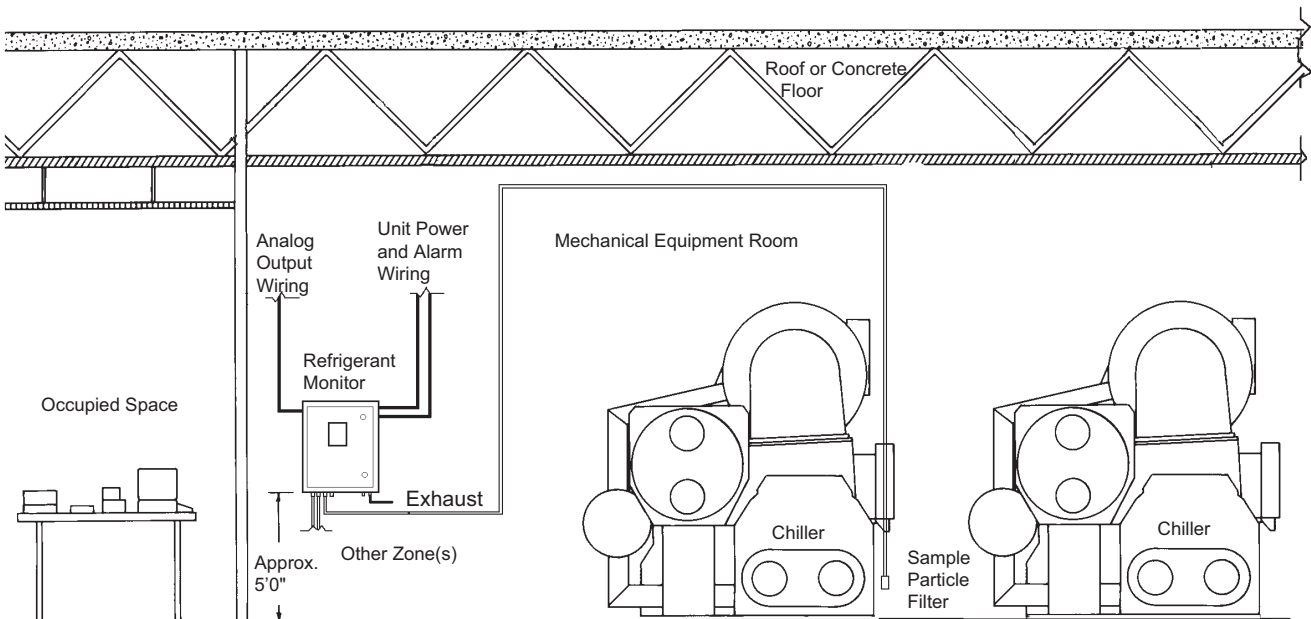

Installation

Room Configuration

Since all fluorocarbon refrigerants are three to five times heavier than air, they will concentrate near the floor and in low areas such as pits and stairwells. Large pits and stairwells should be ventilated and monitored.

Airflow Patterns

Airflow patterns can cause areas of the room to become stagnant and refrigerant vapors to accumulate. The sampling point should be between the refrigerant source (typically the chiller) and the ventilation exhaust inlet. Smoke tubes are useful in determining the ventilation patterns.

Equipment Configuration

The equipment arrangement in the room can also have an impact on the most effective place to sample. As a general guideline, if there is one chiller in the room, sample at the perimeter of the unit. For two chillers, sample between them. For three chillers, sample at the middle chiller. With four or more chillers, multiple monitors or a single monitor with a multi-point sampling system should be used. Typically, a sensing point can handle a radius of 50 feet; however airflow patterns must always be considered.

Activity in the Room

The expected activities in the room must also be considered when determining the sensing point. As stated earlier, refrigerants will concentrate near the floor. Typically, sampling 12-18 inches above the floor is sufficient for early warning and to provide adequate protection for someone working closely to the floor. If it is expected that an occupant's breathing zone may be less than 12-18 inches off the floor, locate the sampling point accordingly.

Note: Select sampling locations which result in the shortest possible line length to reduce transport time.

For more information on equipment room design and monitoring, refer to Trane Application Engineering Manual REF-AM-3, "Refrigeration System Equipment Room Design" available from your local Trane office.

Mounting the Monitor

The monitor has four mounting tabs on the back panel of the enclosure. Securely mount the Refrigerant Monitor to the wall or structure using appropriate mounting hardware.

CAUTION:

Do not mount the monitor directly to a chiller or use brackets other than those provided. Unit vibration may affect the operation of the monitor.

Physical Data

Figure 4 — Physical Data

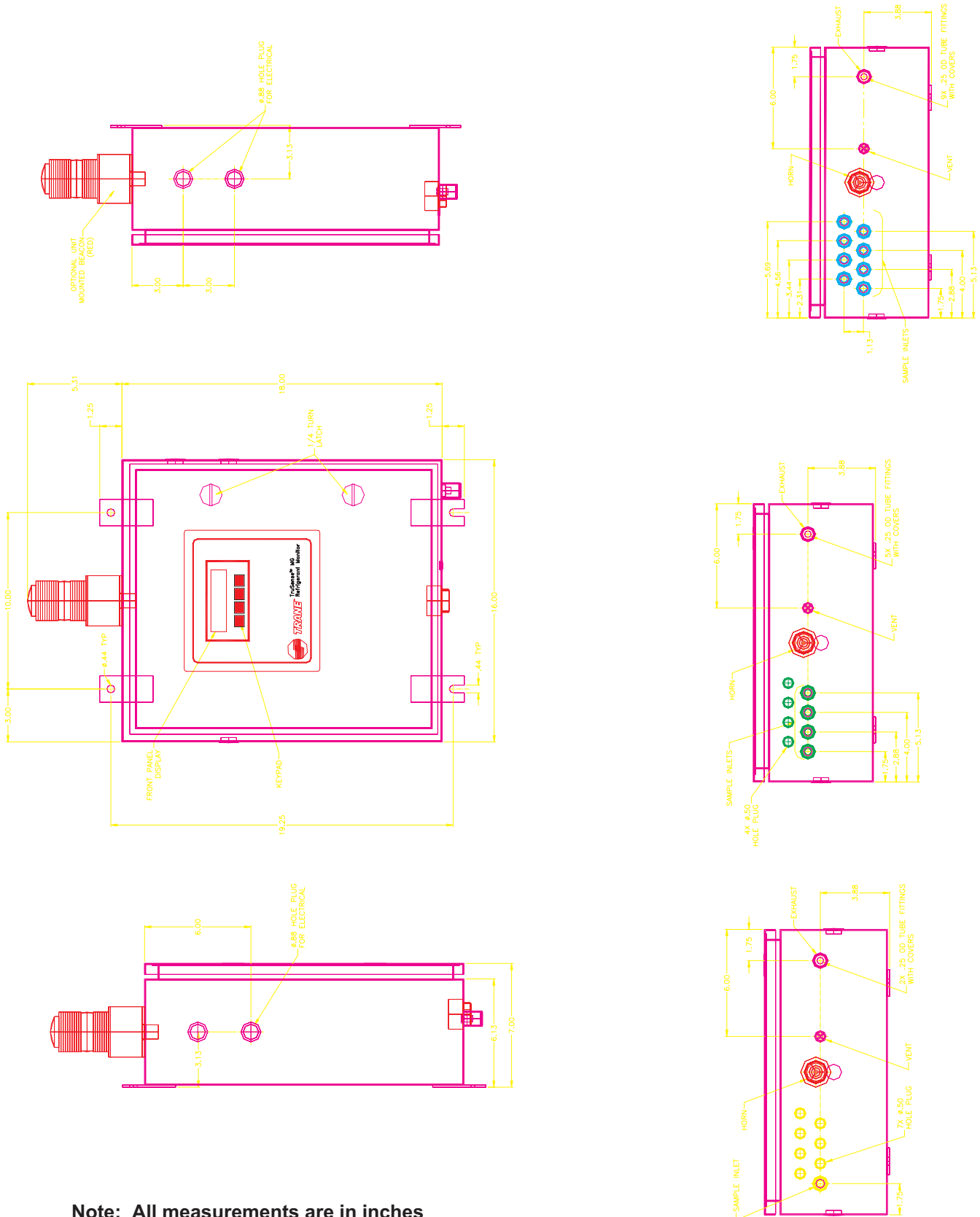

Note: All measurements are in inches

Installation

Sample Tubing Installation

Sample inlet and exhaust connections for the air sampling system are located on the bottom of the unit. (See Figure 4 for locations of the connections). The connection fittings are self-clamping and require no special tools or additional fittings. They are designed to accept 1/4 inch OD copper tubing.

CAUTION:

Insert only clean tubes, cut with a tubing cutter, into the fittings to ensure a smooth, contaminant-free connection.

The sampling line(s) can each be up to 150 feet long using 1/4 inch OD, 1/8" ID copper tube or up to 500 feet long using 1/4" OD, 3/16" ID copper tube.

Note: The maximum total length of the sample and exhaust line(s) is 150 feet or 500 feet respectively.

Note: Install line(s) so that they can be easily removed from the monitor for calibration.

Route the sample tubing to the area to be monitored. 1/4 inch OD rigid copper tubing with flare or compression type fittings is recommended. Soldered connections on the sample line(s) should be avoided due to the possibility of the monitor being sensitive to the solvents in the soldering flux paste. Plastic tubing should be avoided due to its tendency to absorb refrigerants which could possibly cause a delayed alarm and/or slowly leak out gas later resulting in a nuisance alarm.

After the line(s) are installed and BEFORE they are connected to the monitor, they should be blown out with compressed air or nitrogen to remove any debris and leak checked to assure they are leak-free. Then connect the line(s) to the sample port(s) on the monitor and install the end-of-line filters as shown in Figure 5.

All unused sample port(s) must have an end-of-line filter installed to avoid debris entering the unit.

CAUTION:

The end-of-line filters must be in place whenever the monitor's pump is operating. Operation without sample filters will damage the unit.

Note: Trane filter replacement part number is FLR01882.

Exhaust Tubing Installation

If the monitor is located in the same room as the sample inlet(s), the exhaust can be vented back into the room. If sample is coming from a separate area, the exhaust should be piped back to the same area or to another safe area.

CAUTION:

Never connect to a vacuum or pressure source or install in-line devices such as a flow meter in the exhaust lines. Monitor exhausts must vent to atmospheric pressure to avoid damage to the unit.

Detail



Figure 5
Typical Filter Installation

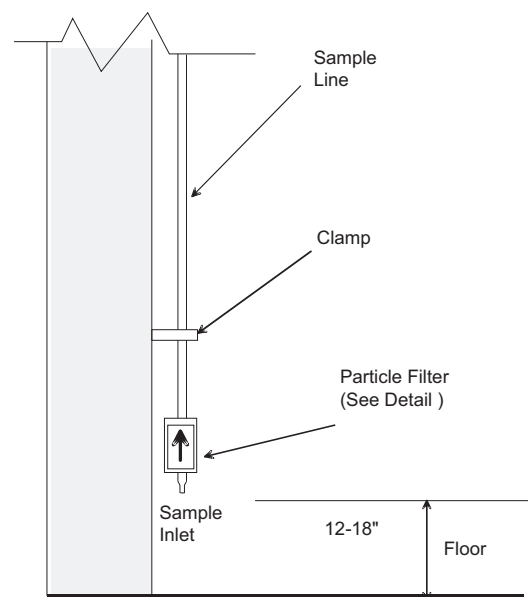

Electrical Connections

⚠ WARNING!

Open all disconnects before making wiring connections. Failure to do so can result in serious personal injury or death due to electrocution.

⚠ CAUTION:

Do not drill additional holes in the enclosure. Use the openings provided for electrical connections. Metal shavings caused by drilling may short out electronic components causing equipment malfunction.

Two 0.875 inch openings are provided on the right side of the unit and one 0.875 inch on the left side for electrical connections to the monitor. The unit ships with the holes plugged. Open only the holes necessary for your specific installation.

Figure 6
Electrical Connections

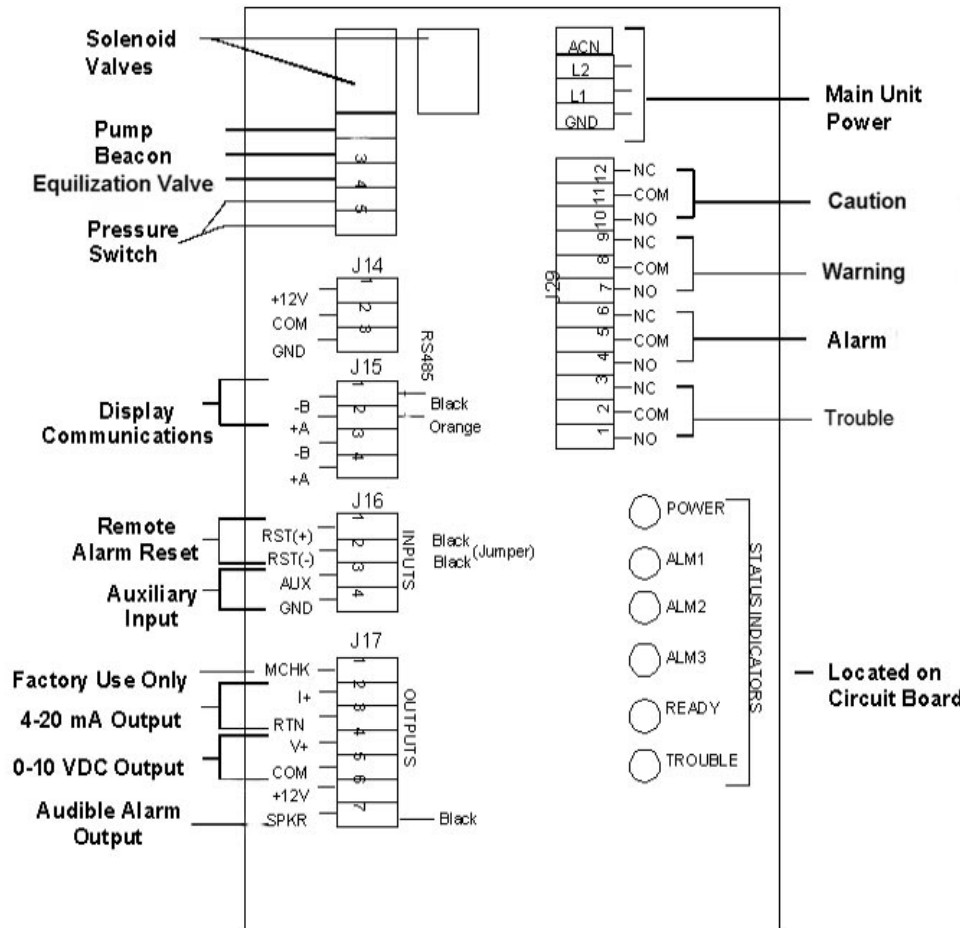

Electrical Connections

Unit Power Wiring

A separate, dedicated power source is recommended for the refrigerant monitor to insure that the unit remains powered when other circuits are shut down for servicing, routine maintenance or shift changes.

The monitor utilizes a wide range power supply which can accept AC power from 100 to 240 volts (nominal), 50 or 60 Hz. The power wiring should enter the unit through one of the openings on the right side of the enclosure. Connections are made to the screw terminals labeled “L1”, “L2”, “ACN” and “GND” located in the upper right side of the unit. (See Figure 6 for location). The maximum wire size that these terminals can accept is #12 AWG.

The incoming power provided to the monitor determines the configuration of the wiring to the main terminal block. Figure 8 shows the wire connections for various voltages.

- I For single fuse 100/120 VAC power connection, connect the power wire to L1, neutral wire to ACN, and ground wire to \perp terminal.
- I For double fuse 220/240 VAC power connection, connect power wires to L1 and L2 and ground wire to \perp terminal.

Note: The monitor ships with fuses in place. See Figure 7.

Figure 7—Fuse Locations

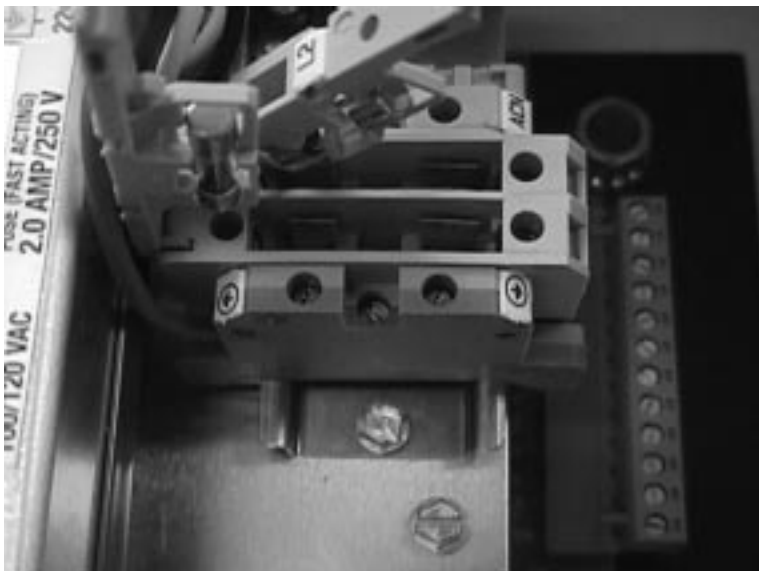
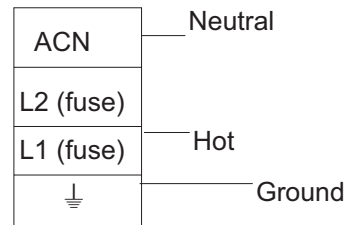
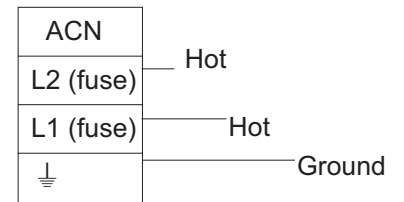

Figure 8 — Power Connections

100/120 VAC



220/240 VAC



Electrical Connections

Alarm Relay Wiring

Three refrigerant level alarm relays and one trouble alarm relay are provided. Each relay has terminals for; Normally Open (N/O), Common (C) and Normally closed (N/C). All relays are Form C, SPDT which can be wired to either close or open its contacts in an alarm condition. The contacts are rated for 240 VAC, 8 amps resistive load.

Relay wiring should enter the unit through one of the openings on the right side of the unit. Connections are made at the internal terminal strip labeled J29 located on the right side of the circuit board. (See Figure 6 for location). The terminal portion of the connector can be unplugged from the circuit board for easier wire connections.

Note: It is recommended that the Trouble relay is wired as normally closed (contacts close on loss of power) to provide an alarm if main power is lost to the unit.

Each relay can be set up as latching or non-latching. Each relay can also be set up as normally energized or normally de-energized.

Analog Output Wiring

Two types of analog outputs, a 4-20 mA and 0-10 VDC, are provided as standard. These voltage and current outputs are proportional to the displayed refrigerant concentration. The scaling of the outputs is software selectable as 0-100 or 0-1000 ppm.

Connections are made to terminal strip J17 located on the lower left side of the main circuit board (See Figure 6). Analog output wiring should enter the unit through the hole provided on the left side of unit. The terminal portion of the connector can be removed from the circuit board for easier connection.

18 AWG twisted pair is recommended; 500 feet maximum length. If shielded wire is necessary, ground the shields of all cables at the receiving end of the signal. Do not ground or connect the shields at the monitor.

4-20 mA

The 4-20 mA output sources current to a separate return. Connections are made to terminals 2 (I+) and 3 (RTN) on terminal strip J17.

0-10 VDC

The 0-10 VDC output sources voltage to 2 K ohms maximum load. Connections are made to terminals 4 (V+) and 5 (COM) on terminal strip J17.

⚠ CAUTION:
Do not install low voltage wiring (<30 volts) with higher voltage wiring (>30 volts). Sharing the same conduit can produce electrical interference resulting in an erratic output.

Electrical Connections

Remote Alarm Reset

The audible alarm and latched refrigerant level alarms can be reset through a switch that has a momentary contact opening (normally closed set of contacts).

Connections are made to terminal strip J16, terminals 1 and 2 with the wiring entering the enclosure through the hole on the left side of the instrument. The unit ships with a jumper across the reset terminals (J16, 1 & 2).

The switch must have signal-level contacts, typically gold flash. The maximum distance from the reset switch to the monitor using 18 AWG shielded wire, is 250 feet.

Note: Shielded wire is required. Ground the shields of all cables at the transmitting end of the signal. Do not ground or connect the shield at the monitor.

Auxiliary Input- Use UL Listed Devices

A 4-20 mA analog input can be made to the monitor from another device such as another refrigerant monitor or an oxygen monitor. See the section titled "Auxiliary Input" in this manual for a detailed description of this feature.

The input wiring should be brought into the enclosure through the hole on the left side of the instrument and connected to terminals 3 (Aux) and 4 (Gnd) on J16. Use 18 AWG, twisted pair, shielded wire. Maximum length of wire run is 250 feet.

Note: Shielded wire is required. Ground the shields of all cables at the transmitting end of the signal. Do not ground or connect the shield at the monitor.

Optional Alarm Beacon

Your unit may have an optional beacon alarm installed. It is factory-wired so no additional wiring is necessary. It lights when any alarm indication is given by the instrument. This function parallels the audible alarm output (when the horn sounds, the beacon will light).

CAUTION:

All field wiring must be done in accordance with national and local electrical codes.

Operation

Display Screens

All instrument operation is performed via the front panel which consists of four keys and a two-line by 20-character vacuum fluorescent display. The most commonly used, self-explanatory screens appear on the following pages. Simply follow the on-screen menus. The step-by-step approach guides you through each operation.

The Display Screen Overview (FIGURE 9) shows a general system function flow. See the following FIGURES for specific Display Screen details:

Start-up and Normal Operation Screens

(FIGURE 10)

Calibration Screens

(FIGURES 11 through 13)

Set-up Screens

(FIGURES 14 through 23).

Information Screens

(FIGURES 24 through 27)

Operation

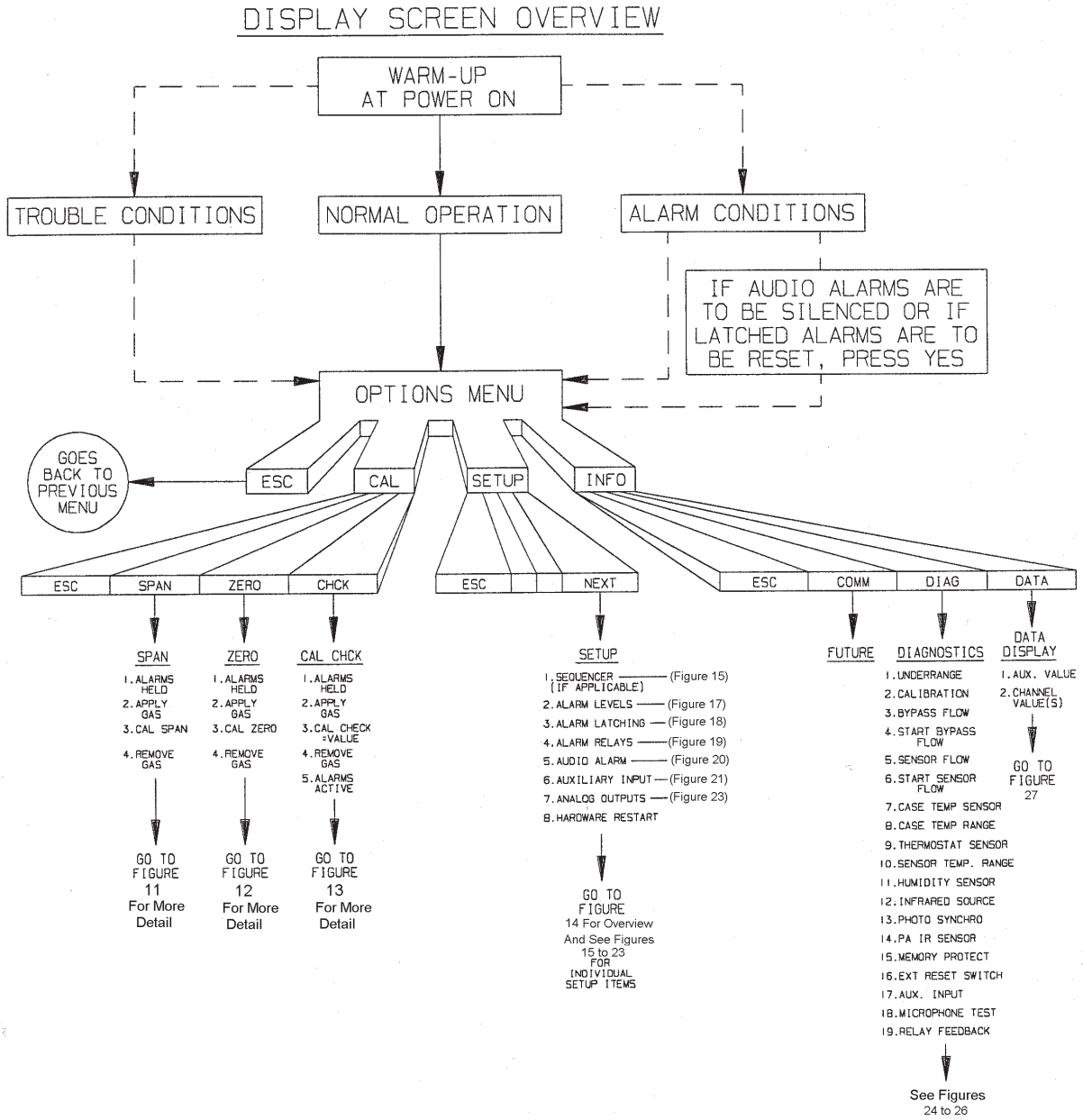

Figure 9

Operation

START-UP AND NORMAL OPERATION SCREENS

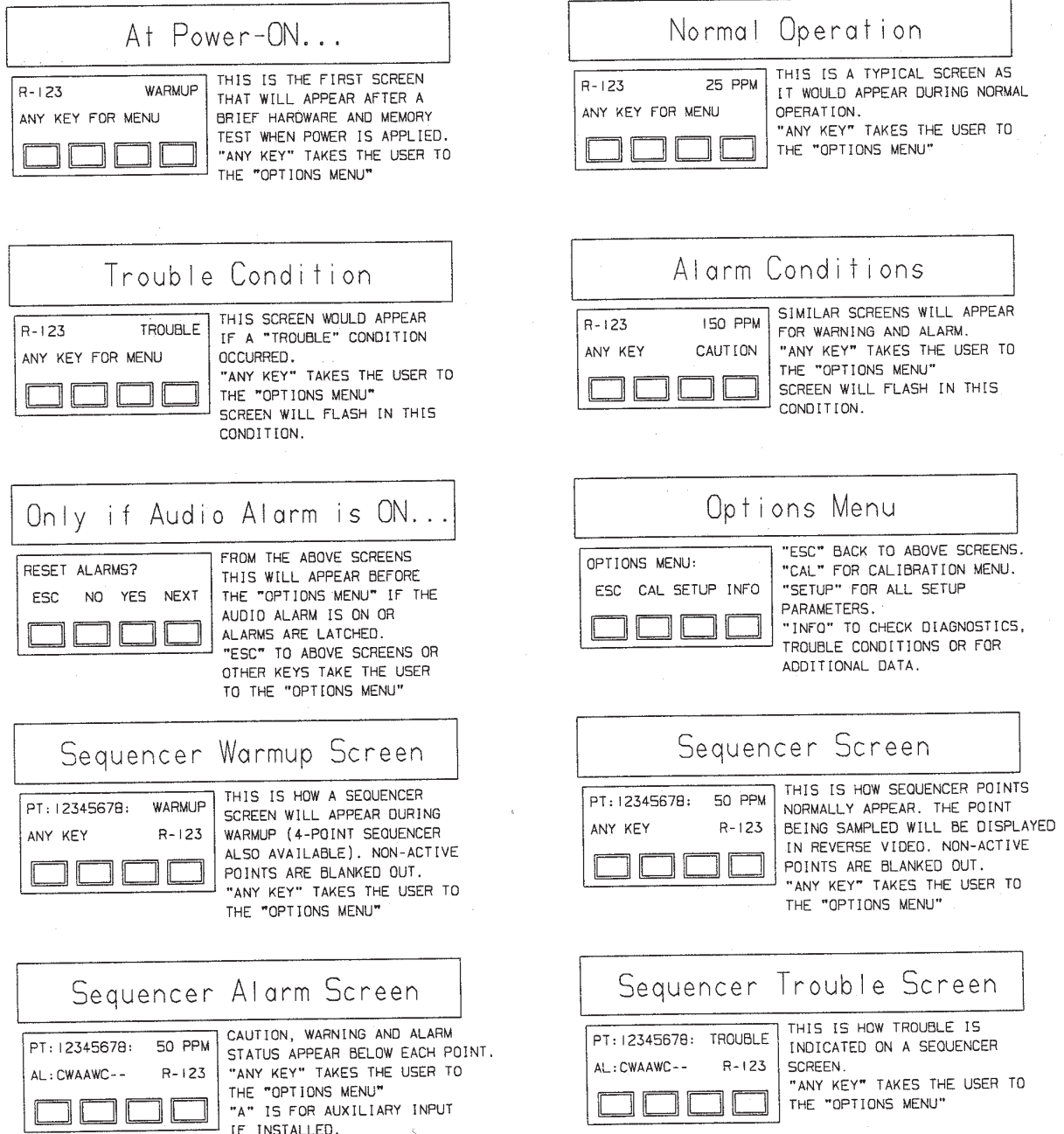

Figure 10

Operation

Calibration Menu

SPAN CALIBRATION

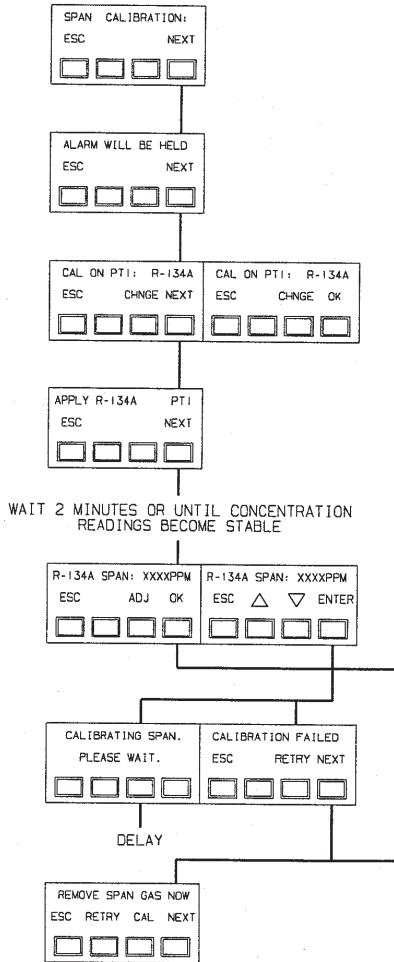

Figure 11

Calibration Menu

ZERO CALIBRATION

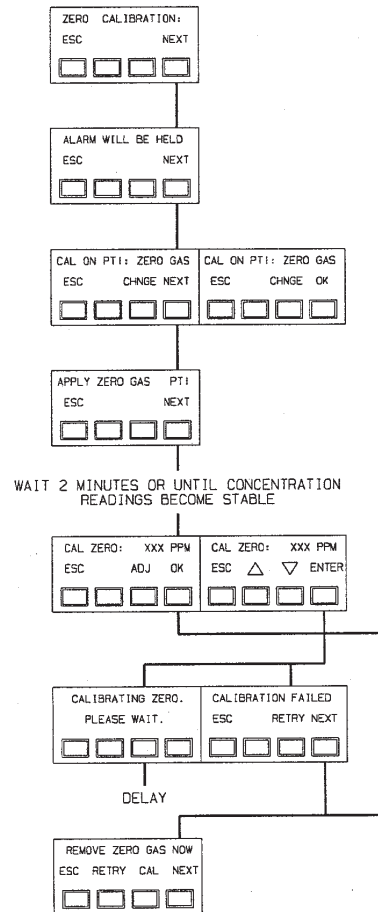

Figure 12

Operation

Calibration Menu

CHECK CALIBRATION

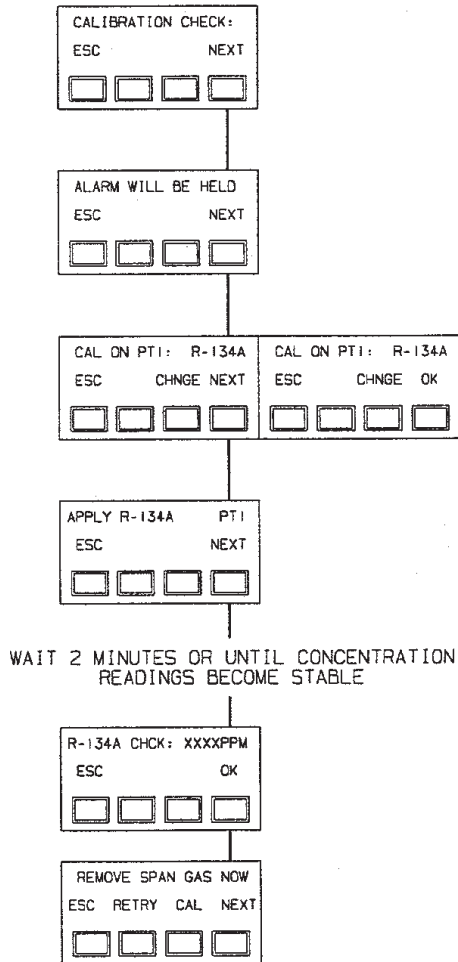

Figure 13

Operation

Setup Menu

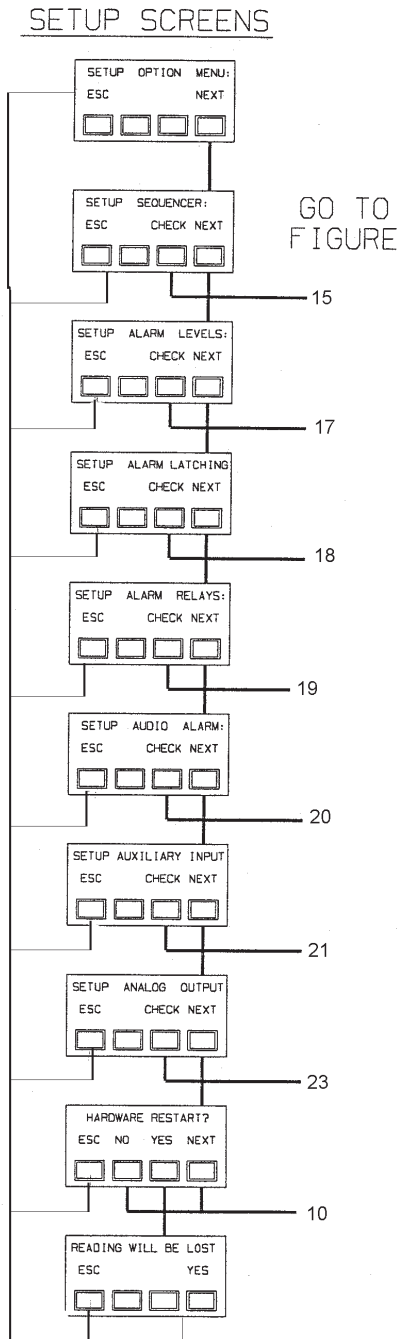

Figure 14

Operation

Setup Menu

SEQUENCER SETUP SCREENS

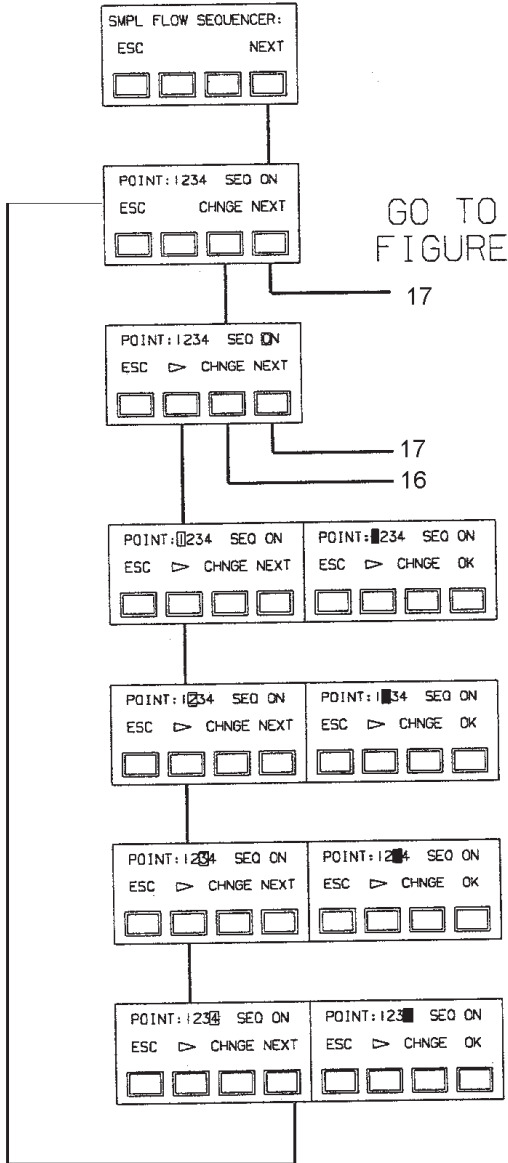

Figure 15

Setup Menu

SEQUENCER SETUP SCREENS

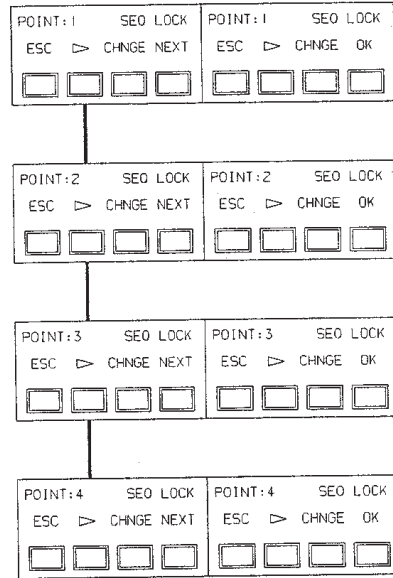

Figure 16

Operation

Setup Menu

ALARM LEVEL SCREENS

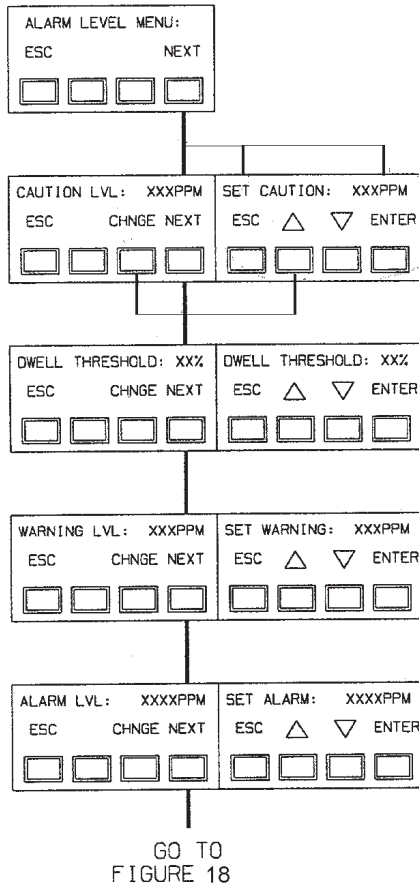

Figure 17

Caution, Warning and Alarm Levels :

The PPM level at which a concentration alarm will be displayed and the appropriate alarm relay activated. Press “CHNGE” and the corresponding Δ or ▽ key to increase or decrease the setting. Alarm levels are adjustable in steps of 1 PPM over the following ranges:

All Refrigerants	Low Limit	High Limit
Caution	3 ppm	Warning Level -1
Warning	Caution Level +1	Alarm Level -1
Alarm	Warning Level +1	1000 ppm

Refrigerant	Caution	Warning	Alarm
HCFC-123	50	150	500
CFC-11, HCFC-22,HFC-134a, CFC-12, CFC-113, CFC-114, CFC-500, CFC-502	50	150	1000
Ammonia	10	25	50

Note: These are the current recommended alarm level values at the time of printing. They can be easily adjusted as required.

Factory default values are:

Dwell Threshold: This setting selects the percentage of an Alarm Level 1 concentration which will result in a 60 second extended sample time on the channel. Range is 30 to 70%. Press “CHNGE” and the corresponding Δ or ▽ key to increase or decrease the setting. Factory default is 70%. This screen is only displayed if the channel scanner is “Installed”.

Operation

Setup Menu

Alarm Latching Screens

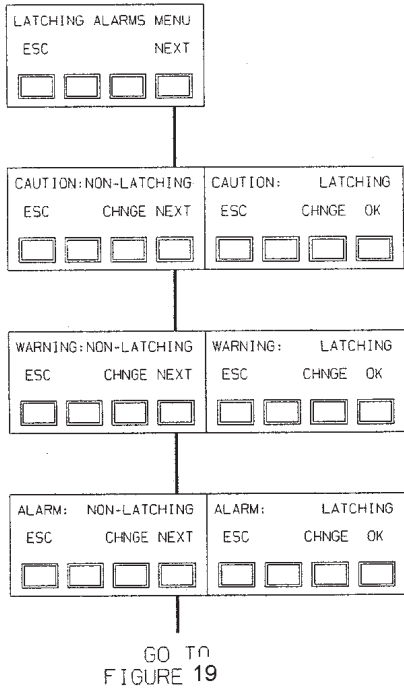

Figure 18

Caution, Warning and Alarm level Relay Configuration: The three alarm relays can be configured individually to “latching” or “non-latching” when the alarm level is exceeded. Factory default is non-latching.

With “non-latching” alarms, the unit will automatically reset the alarm status, de-energize the alarm relay(s) and revert to normal operation when the refrigerant concentration falls below the preset alarm level.

“Latching” alarms will stay activated until acknowledged (reset) by pressing the “Yes” key on the keypad while viewing the alarm. If the alarm condition remains, the alarm will immediately re-latch. If the alarm condition was cleared, the alarm will clear in about five second

Operation

Setup Menu

Alarm Relay Screens

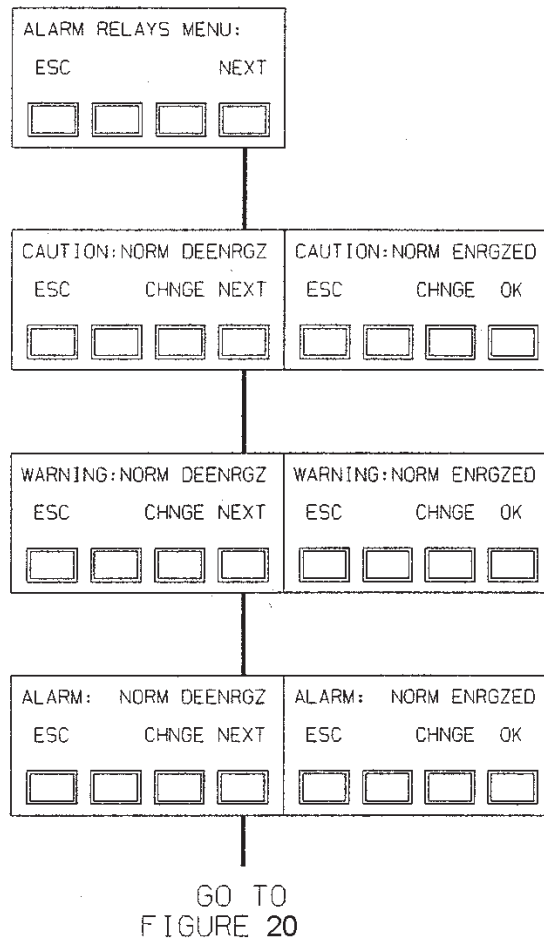

Figure 19

Operation

Setup Menu

AUDIO ALARM SCREENS

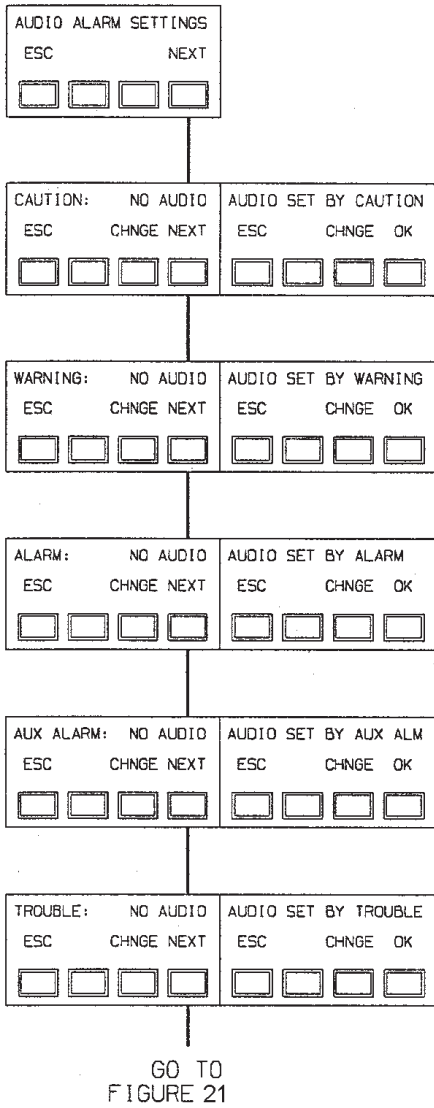

Figure 20

Setup Menu

AUXILIARY ALARM SCREENS

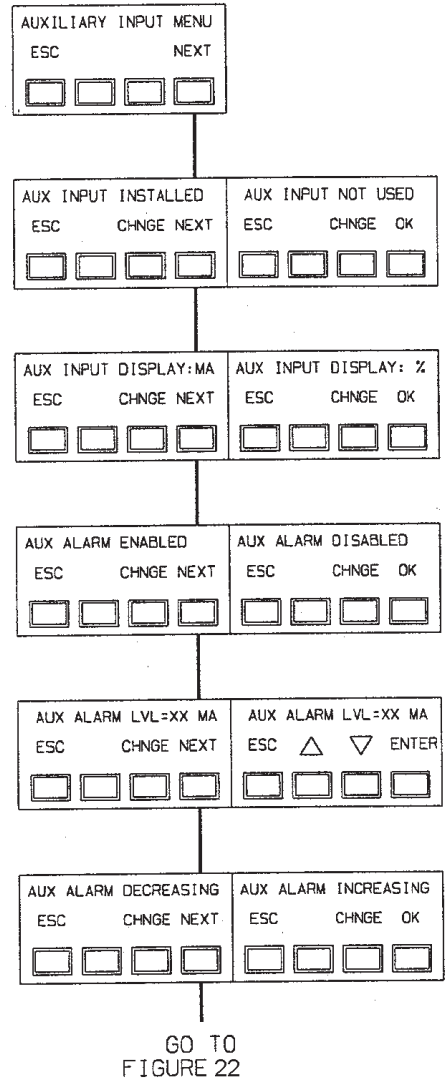

Figure 21

Operation

Setup Menu

AUXILIARY ALARM SCREENS

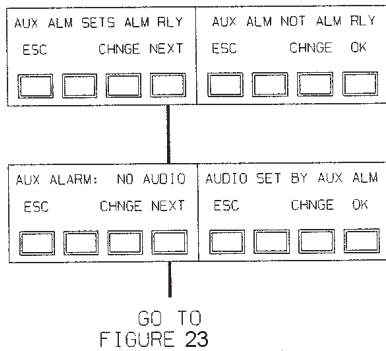

Figure 22

Auxiliary Input: This item selects whether a 4-20 mA auxiliary input is being used. Options are “Installed” and “Not Installed”. Factory default is “Not Installed”. (See “Auxiliary Input” section of this manual for more information).

Aux Input Alarm: This input determines if the Auxiliary Input will activate alarms on the monitor. Options are “Enabled” and “Disabled”. If the alarm is enabled, the auxiliary input will alarm through the unit Level 3 alarm relay. If “Disabled” no alarms will be activated. This screen is displayed only if the Auxiliary Input is “Installed”. (See “Auxiliary Input” section of this manual for more information).

Auxiliary Alarm Level: Used to set the mA level from the Auxiliary device which will result in a Level 3 alarm if the Auxiliary Alarm was enabled on the previous screen. This screen is displayed only if the Auxiliary Input is “Installed”. (See “Auxiliary Input” section of this manual for more information).

Aux Input Alarm Direction: This setting determines if the Auxiliary Input Alarm is activated above or below the alarm mA setpoint.

Audible Alarm for Aux: Used to set the audible alarm to sound if an auxiliary input is in alarm. The factory default is “No Audio”.

Operation

Setup Menu

ANALOG OUTPUT SCREENS

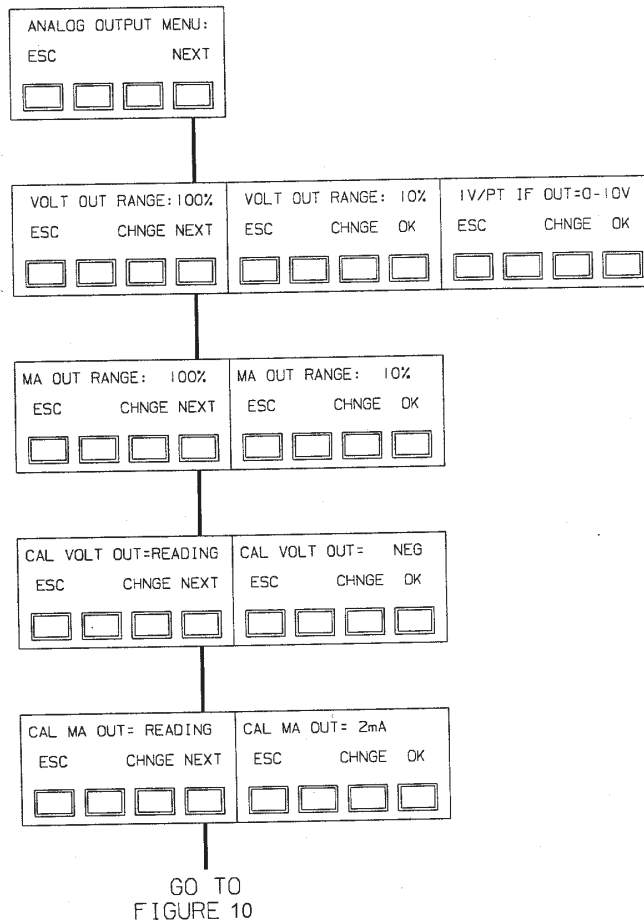
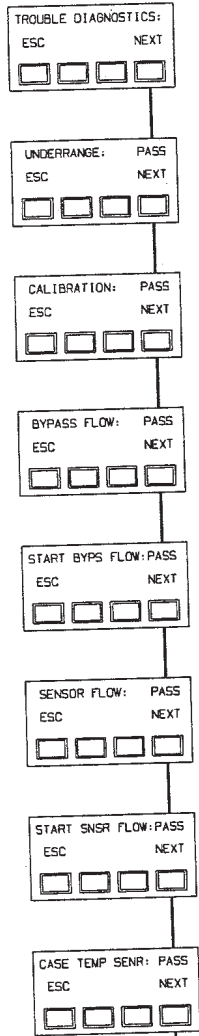

Figure 23

Operation

Information Menu

DIAGNOSTIC SCREENS



GO TO
FIGURE 25

Figure 24

Information Menu

DIAGNOSTIC SCREENS

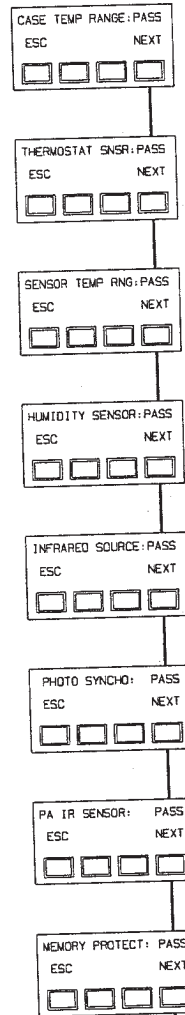

GO TO
FIGURE 26

Figure 25

Operation

Information Menu

DIAGNOSTIC SCREENS

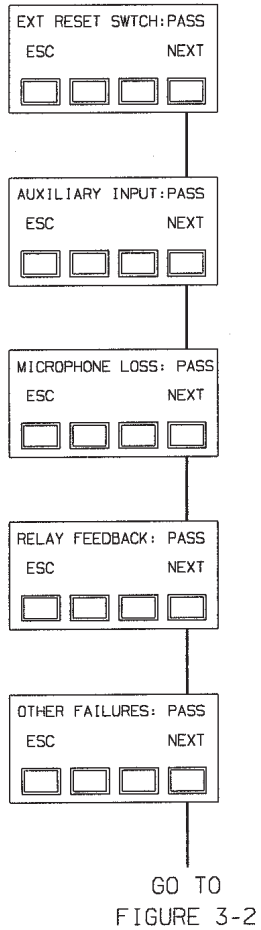

Figure 26

Information Menu

DATA SCREENS

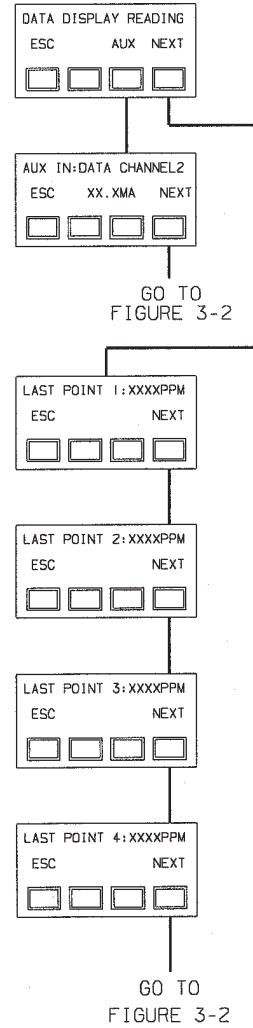

Figure 27

Operation

Remote Alarm Reset

Latched refrigerant alarms can be acknowledged (Reset) locally by pressing the “Yes” key on the clear language display while viewing the alarm message.

Latched refrigerant level alarms can also be remotely reset through a momentary contact opening.

This capability can be used to determine if an alarm condition has cleared or still exists. If the refrigerant concentration is below the preset alarm ppm point, the alarm will reset and will not re-latch. If the concentration is above the alarm ppm point, the alarm will immediately re-latch.

The monitor ships with a jumper between terminals 1 and 2 of J16 on the monitor module. This jumper is removed and replaced with a normally closed switch if the remote reset feature is used.

To remotely reset an alarm, apply a momentary contact opening to terminals 1 (RST+) and 2 (RST-) on the J16 terminal strip. A switch with signal-level contacts, typically gold flashed, must be used. The maximum distance from the reset switch to the monitor using 18 AWG shielded wire is 300 feet.

Audible Alarm Output

A 12 VDC output from the module is provided as standard to power a piezo-electric audible alarm horn (150 mA non-inductive max. load). The audible horn is installed in the bottom of the monitor enclosure. The horn is connected to terminals 6 (+12V) and 7 (SPKR) on terminal block J17 of the module.

The audible horn can be configured to sound whenever the selected Level 1, 2 or 3 alarm is active. The alarm configuration “Latched” or “Unlatched” will be the same as what has been set for the selected Level 1, 2 or 3 alarm. Pressing “Yes” from the “Reset Alarms” screen will acknowledge a latched alarm and silence the audible alarm. The audible alarm is then reset when the refrigerant concentration falls below the preset alarm point.

The audible alarm can also be configured to sound if the monitor is displaying a TROUBLE (malfunction) diagnostic. If the audible alarm is active, it can be silenced by pressing “Yes” from the “Reset Alarm” screen or when the diagnostic clears.

Operation

Auxiliary Input- Use UL Listed Devices

The monitor is capable of accepting an auxiliary 4-20 mA input from another source. This feature could be used to tie in a device such as an oxygen monitor so it could alarm through the refrigerant monitor alarm system. Specifically, when the mA output from the auxiliary device is above/below the Auxiliary Alarm level setting, the Alarm Relay on the monitor module will change state. When the Auxiliary input option is used, the Alarm Relay will activate when either the refrigerant concentration exceeds the Alarm setting or the preset Auxiliary Input mA value is exceeded.

Figure 28
Auxiliary Alarm Example

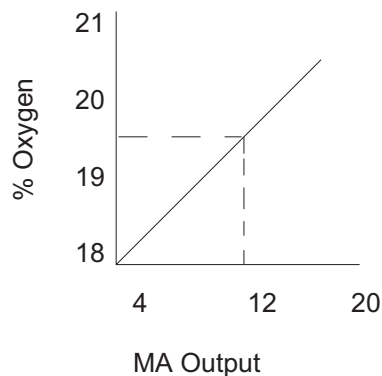

Depending on the device used, it may be necessary to alarm when the input mA value is below the alarm set point while other devices need to alarm above the alarm set point. An example of alarming when the input falls below the set point level might be an oxygen monitor where the output is proportional to the % oxygen. As the available oxygen drops, so does the mA input. By contrast, a refrigerant monitor input that increases with concentration would need to be set up to alarm when the mA input goes above the setting.

The auxiliary input is enabled and the other set-up parameters are set-up through software in the "Auxiliary Input" menu.

The optional audible alarm can be configured to sound if the auxiliary input exceeds the auxiliary alarm level. The horn can be silenced by pressing "Yes" from the "Reset Alarm" screen or when the auxiliary alarm input drops below the auxiliary alarm level.

To properly determine the auxiliary device alarm point, the scaling in relation to the 4-20 mA range of the device must be known.

Figure 28 shows an example of an oxygen monitor in which an alarm was desired at 19.5% sensed oxygen level.

In this example, the "Auxiliary Alarm Level" is set at 12.0 mA and the direction for alarm is set to "Decreasing".

Operation

Monitor Cross-Sensitivity

The Trane Refrigerant Monitor is factory calibrated specifically for the refrigerant of interest. With the large number of different chemicals and refrigerants in equipment rooms, it is very important that an air monitoring device be as resistant to cross-sensitivity as possible. The photo-acoustic technology used in this instrument is one of the most selective available; however, the instrument may respond, in varying degrees, to other chemicals that may be in the monitored area. Listed below are the instrument's sensitivity to 100 ppm of other commonly used refrigerants when calibrated for the specific refrigerant listed. These are typical values for reference only.

Example: A monitor calibrated for HCFC-123 will display 4 ppm when exposed to 100 ppm of HCFC-22.

Refrigerant	Response
CFC-11	1 PPM
HFC-134a	140 PPM
HCFC-22	4 PPM
CFC-113	80 PPM

Calibrated for HCFC-123

Refrigerant	Response
HCFC-123	3 PPM
HFC-134a	20 PPM
HCFC-22	30 PPM
CFC-113	25 PPM

Refrigerant	Response
HFC-134a	25 PPM
CFC-11	16 PPM
HCFC-123	35 PPM

Calibrated for CFC-11

Refrigerant	Response
HCFC-22	1 PPM
HCFC-123	8 PPM
CFC-11	2 PPM

Calibrated for HCFC-22

Calibrated for HFC-134a

Due to the large number of possible interferants other than refrigerants, it is impractical to list them. Direct any questions regarding specific interferants that are expected to be in the monitored area to your local Trane office.

Note: Cross-sensitivity data not verified during UL testing.

Calibration

Introduction

This section details the recommended field calibration procedure for the Trane Model RMWE refrigerant monitor. The monitor is factory calibrated for the specific refrigerant desired, however, it is recommended that the calibration be checked regularly, at a minimum annually, and a log kept detailing any adjustments required. This Installation, Operation and Maintenance manual should be referenced to assist in operating the display and identifying components or connection points.

Calibration Equipment

1. Trane™ Calibration Kit TOL00170 containing:
 - Zero Gas Scrubber FLR01403
 - Flow Regulator
 - Interconnecting Tubing and Fittings
 - Span Gas Scrubber FLR01404
 - Carrying Case
2. A canister of the specific refrigerant span gas is required.

Refrigerant	Kit	PPM
R-11	TOL00171	30
R-22	TOL00172	30
R-123	TOL00173	30
R134a	TOL00174	30

The RMWE test regulator releases just over 2.0 liters per minute. A 100 liter bottle would last about 50 minutes.

The used calibration gas canisters and the various filters are not considered hazardous waste due to the small concentration of refrigerant. If a large number of canisters or filters were being dumped, this might be an issue and require further investigation. Local codes apply.

Monitor calibration should be performed only by qualified personnel familiar with the instrument and its operation.

⚠ WARNING!

During calibration, the monitor is not in service and any alarm conditions that may occur during the calibration sequence will not be recognized, possibly resulting in serious personal injury or death. Operate permanent or portable ventilation as necessary.

Figure 29 — Various Sample Inlet Views

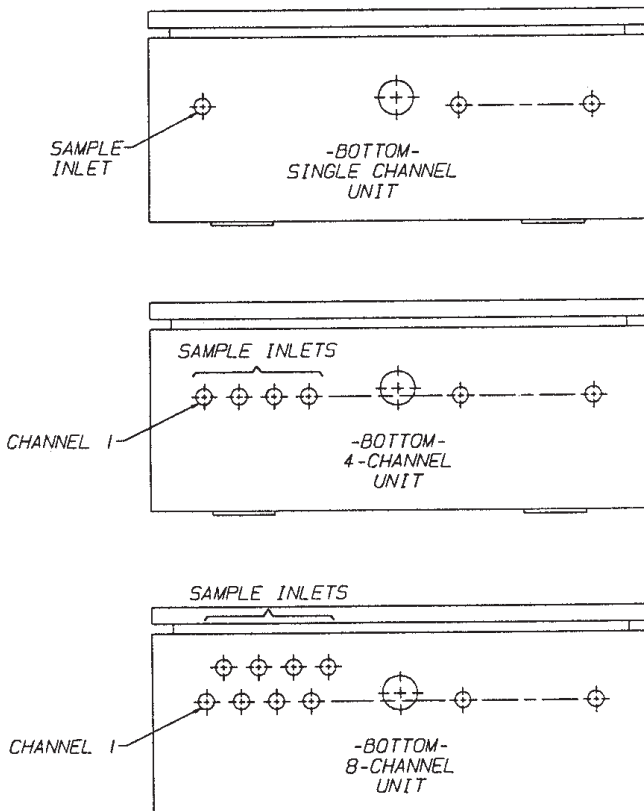

Calibration

Preparing for Calibration

1. Ensure the area surrounding the monitor is free from any gas hazard. Operate permanent or portable ventilation as necessary.
2. Unit should be operating for at least two hours before a calibration check is attempted.
3. Identify the Channel 1 sample inlet on your monitor, see Figure 29.
4. Remove the gas sampling tubing from the inlet fitting.
5. Before analyzing gases, familiarize yourself with the calibration screens by stepping the monitor through the whole sequence. Press the keys in the following order:

Calibration Procedures

Zeroing the Monitor

1. Follow the sequence for the Zero Calibration as shown in Table 1, steps 1-9.
2. When the “Apply Zero Gas” (Step 7) screen is displayed, connect the Zero Gas Scrubber OR the Zero Gas Canister to the monitor inlet as shown in Figure 30.
3. Press the Next button (Step 8)
4. The actual gas concentration detected by the instrument appears on the display. Wait at least three minutes for a stable reading.

If the reading is zero press OK. if the reading is not zero, press the Adjust button. Press the ↑ or ↓ buttons to increase or decrease the reading until it reads zero.
5. Remove the Zero Gas (Step 9).

Table 1 —Zero Calibration Procedure

	Press	Result
1	ANY KEY	BRINGS UP MENU
2	CAL	BRINGS UP CAL MENU
3	USER	ALLOWS ADJUSTMENTS
4	ZERO	ALLOWS ZERO CALIBRATION
5	NEXT	PROMPT: ALARMS ARE NOW OFF
6	NEXT	PROMPT: SAMPLE POINT 1 TO BE USED
7	NEXT	PROMPT: APPLY ZERO GAS
8	NEXT	PROMPT: ADJUST OR OK READING
9	OK	PROMPT: REMOVE ZERO GAS
10	SPAN	PROMPT: GO INTO SPAN CALIBRATION
11	NEXT	PROMPT: ALARMS ARE NOW OFF
12	NEXT	PROMPT: SAMPLE POINT 1 TO BE USED
13	NEXT	PROMPT: APPLY SPAN GAS
14	NEXT	PROMPT: ADJUST OR OK READING
15	OK	PROMPT: REMOVE SPAN GAS

Calibration

Figure 30
Zero Calibration Connections

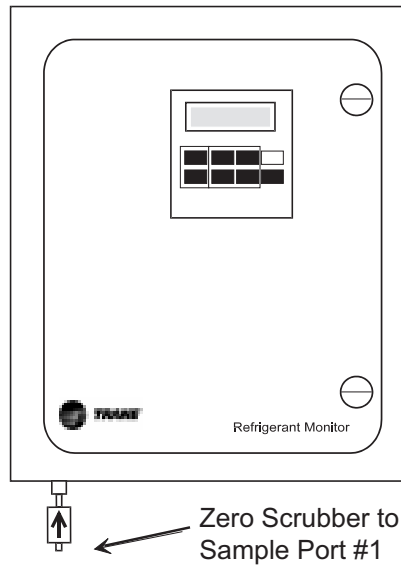

Note: If Zero Gas is used, connect canister to Sample Port #1 using the arrangement similar to what is shown in Figure 13, substituting the Zero canister for the Span Canister and the Zero Scrubber for Span Gas Scrubber.

Figure 31
Span Calibration Connections

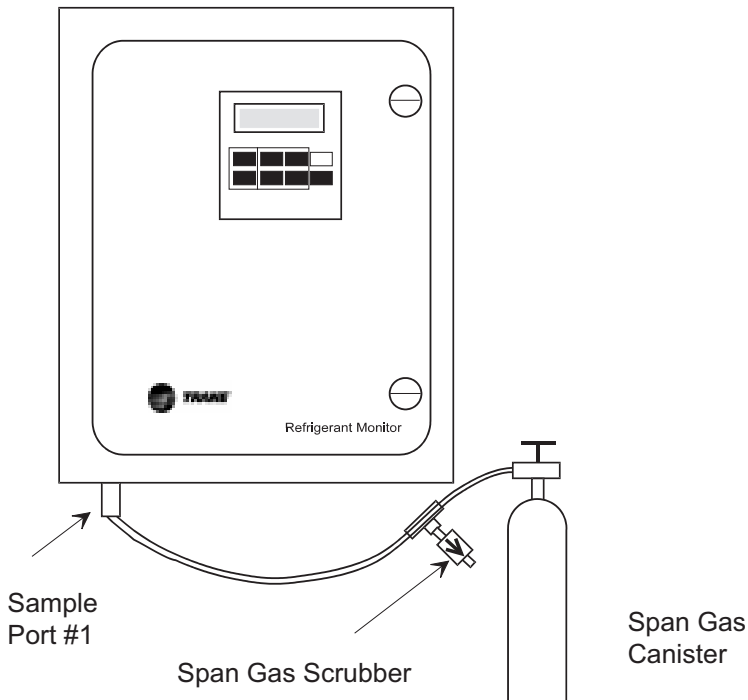

Spanning the Monitor

1. Follow the sequence for span calibration as shown in Table 1, steps 10-17.
2. When span gas is required, a span gas cylinder must be attached to the inlet as shown in Figure 31.
3. Press the Next button.
4. Wait at least three minutes for a stable reading. Compare the displayed PPM value to what is listed on the calibration canister.

If the displayed value matches the span gas concentration, press OK.

If the displayed value differs from the value on the canister, press the addition button.

Press the \uparrow or \downarrow button until the displayed value matches the calibration gas value.

If the calibration was successful, the new span values are stored and will be used for all future readings.

If the calibration failed, the monitor will revert back to the values previously stored.

Note: If calibration continues to fail, refer to the "Troubleshooting" section of this manual.

5. Disconnect the span gas canister. Reattach the sampling line to the monitor inlet.

⚠ WARNING!

If the sampling line is not re-attached, the monitor cannot sample from the remote location.

6. Log the data and note any adjustments made on a monitor calibration log.
7. Return all parts to the Calibration Kit carrying case.

Multi-Refrigerant Capability

Introduction

The RMWE refrigerant monitor is available with the capability to detect up to six different refrigerant gases. This capability is used when multiple chillers using different refrigerants are located together or in separate machinery rooms. Only one refrigerant monitor is necessary. This reduces the initial expense as well as installation, wiring and cost of ownership expenses.

Your refrigerant monitor is ordered and built for the particular types of refrigerants in use. The instrument is ready to monitor; however, it is necessary to configure the unit to your specific requirements.

Your refrigerant monitor may contain an internal multi-point sequencer, enabling your unit to sample from up to eight individual sampling locations. Each sampling point of the multi-point sequencer must be assigned one of the refrigerant gas types. This allows the unit to correctly detect and compute the proper readings for the gas type specified for that point.

Note: Multi-Refrigerant capabilities are not evaluated by Underwriters Laboratories Inc.

Initial Setup

The RMWE refrigerant monitor with multiple refrigerant detection capability must be programmed at the time of installation. This allows the unit to respond correctly to the gas expected at each particular sampling point. During set-up, a menu option relates each sampling point to one of the gases the instrument is capable of detecting.

⚠ CAUTION

The refrigerant monitor will only report proper gas readings if the particular gas selected to be monitored at each sampling point is actually present at that point. If another refrigerant that the unit is capable of monitoring enters the sample line, the reading will not be accurate.

Determine which refrigerant gas is likely to enter each sample line. Mark each sample line and place the sample tubing on one of the inlet ports.

See Figures 32 through 34 for gas by Point Setup Screens and Alarm Level Screens. All other operating characteristics of the Refrigerant Monitor remain unchanged. Refer to Figures 15 through 23 for individual setup screens.

Calibration

It is only necessary to calibrate the instrument with one gas, even though the refrigerant monitor with multiple gas detection capability can respond to up to six different refrigerant gases. Calibrate the instrument according to the instructions in this manual.

The only variation of the calibration procedure for the multi-gas refrigerant monitor is to apply span gas to only one of the sample points. The particular sampling point chosen must be configured to monitor that particular gas. During the calibration process, the span values of the other channels or gases will be corrected appropriately.

Display Screens

The refrigerant monitor with multiple gas detection capability uses display screens which differ slightly from the standard unit. The different display screens are in the Setup of the sequencer section of the instrument. Refer to Figure 14. The following figures (Figures 32 through 34) allow the user to define the refrigerant gas that is expected at each sampling point. Also, they determine which refrigerant gas is used for calibration by selecting the sampling point configured for that particular gas.

Multi-Refrigerant Capability

GAS BY POINT SETUP SCREENS

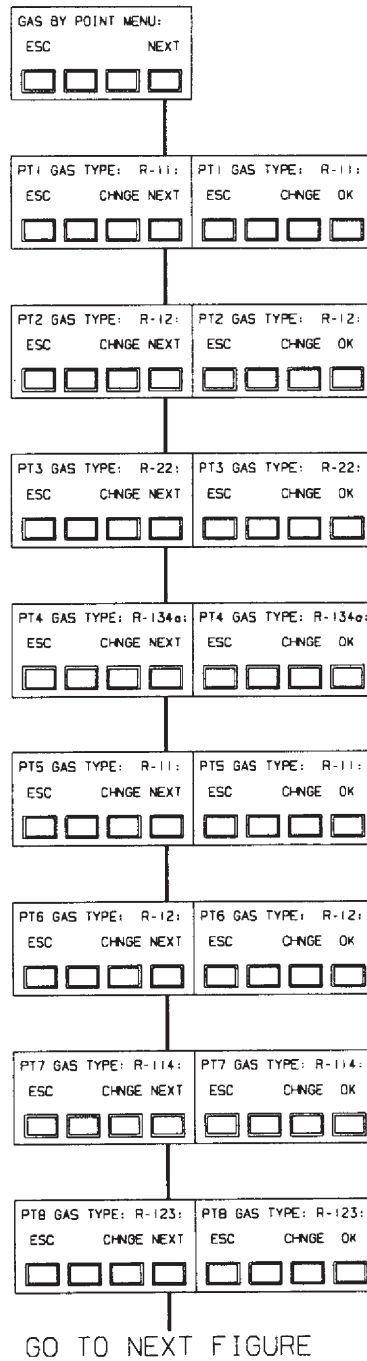

Figure 32

Multi-Refrigerant Capability

ALARM LEVEL SCREENS

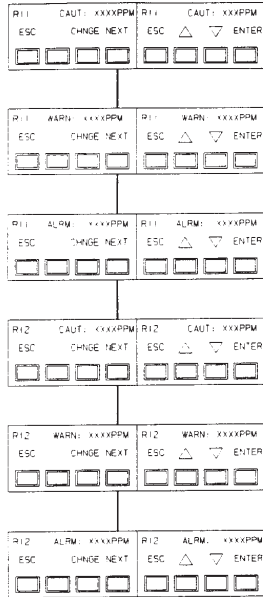

Figure 33

ALARM LEVEL SCREENS

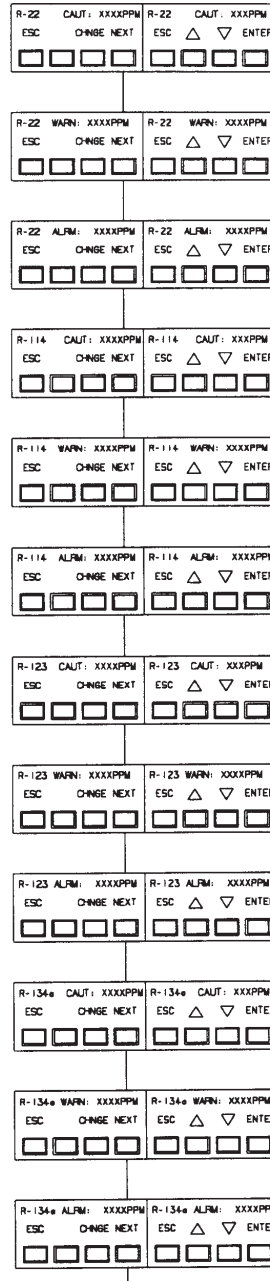

Figure 34

Troubleshooting

Trouble	Description	Solution
Unit will not turn ON	No power	1. Check AC power to unit.
		2. Verify AC power to unit is wired properly.
		3. Replace L1 and/or L2 fuse.
		4. Check for loose wires on terminal barrier input.
		5. Check wiring to the unit power supply. Remove power supply cover and check fuse; replace if necessary.
		6. Check input cable to main board on left side of power supply.
		7. Check for 12VDC power supply output. Connect the DVM negative lead to TP5 and the positive lead to TPSPD1. Adjust Volt 2 pot on the power supply if necessary.
		8. Move the DVM positive lead to TPSPD3. The voltage should be 5 VDC. Adjust Volt 1 pot on power supply if necessary.
Beacon will not light	Beacon alarm	1. Check that plug is connected to circuit board: J10
		2. Verify the audio option is used in the setup screens.
		3. Replace beacon assembly.
Under-range failed	Zero limit is minus 10 ppm	1. Adjust display zero to 0.0 via the keypad with zero air or zero scrubber applied.
		2. Check the zero air cylinder; replace if necessary.
		3. Check the zero scrubber; replace if necessary.
Calibration failed	Coefficients out of range	1. Replace zero scrubber or change zero air supply.
		2. Check span gas supply.
		3. Check all tubing, filters and fittings for leaks.
		4. For sequencer units, make sure the unit is locked on the selected sample port used for calibration.
		5. Leak test the flow system.
		6. Not field repairable.
Bypass flow failed	Leaky or blocked bypass line	1. Remove all input lines to unit. Attach one line at a time to check for bypass input. The line that causes flow failure is the problem; check the line's end-of-line filter.
		2. Check inlet fitting, tubing, orifices, bypass pressure switch, and bypass manifold tubing.
		3. Check pressure switch for 4 VDC ON /OFF switching. Check cable terminals and plug end at BP/SCN. Replace the bypass pressure switch if necessary.
		4. Check operation of all bypass valves in manifold.
		5. Leak test the flow system.

Troubleshooting

Trouble	Description	Solution
Start bypass flow failed	Leaky or blocked bypass line at startup of unit	<ol style="list-style-type: none"> 1. Same as bypass flow failure. Check as above, turn unit off and restart unit. 2. Leak test the flow system.
Sensor flow failed	Leaky or blocked sample line	<ol style="list-style-type: none"> 1. Remove all input lines to the unit. Attach one line at a time to check for sample input. Check all ends of line filters. Sample flow failure is always the present point being sampled. 2. Remove the optical bench cover. Check the inlet fitting, tubing, sample filter, tubing to the optical bench inlet fitting, outlet fitting from the optical bench, sample pressure switch, and sample manifold tubing. 3. Check the sample pressure switch for 4 VDC ON and Off switching. Check the cable terminals and plug end at press/sample connector. Replace pressure switch if necessary. 4. Check operation of all manifold sample valves. Check the optical bench inlet and outlet valves. 5. Check operation of all manifold sample valves. Check the optical bench inlet and outlet valves. 6. Leak test the flow system.
Start sensor flow failed	Leaky or blocked sample flow line at unit startup	<ol style="list-style-type: none"> 1. Same as sensor flow failure. Check as above; turn unit OFF and re-start unit. 2. Leak test the flow system.
Case temperature failed	Main board component	1. Not field repairable
Case temperature range failed	Case temperature is 0 to 90° C	1. Not field repairable
Thermostat sensor failed	Controls optical bench inside temperature	1. Not field repairable
Sensor temperature range failed	Checks for temperature range of 45 to 90°C	1. Not field repairable
Humidity sensor failed	Check H2O sensor output	1. Not field repairable
Infrared source failed	Checks the I of source assembly	1. Not field repairable
Photo synchro failed	Checks the chopper for operation	1. Not field repairable
PAIR sensor failed	Checks the sensor microphone for output	1. Not field repairable

Troubleshooting

Trouble	Description	Solution
Display Failure	Display communications	1. Check RS485 connector on J15, terminals 1 and 2.
		2. Check for broken or cracked display.
		3. Remove rear panel cover and check cables between the display and the display board.
Audio alarm failure	Audio alarm	1. Check output terminals 6 and 7 on J17.
		2. Check for faulty horn buzzer.

Troubleshooting

Figure 35a—Single Channel Model

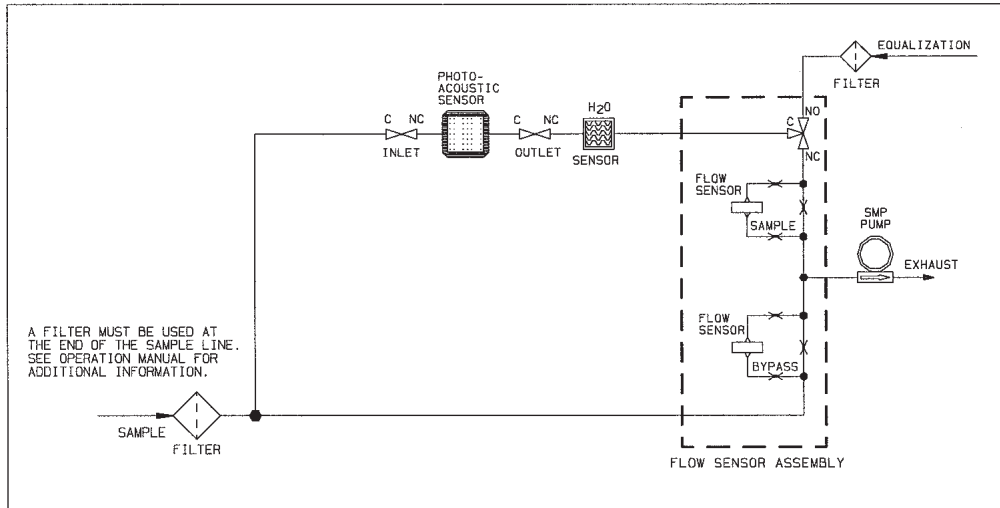

Figure 35b—Four Channel Model

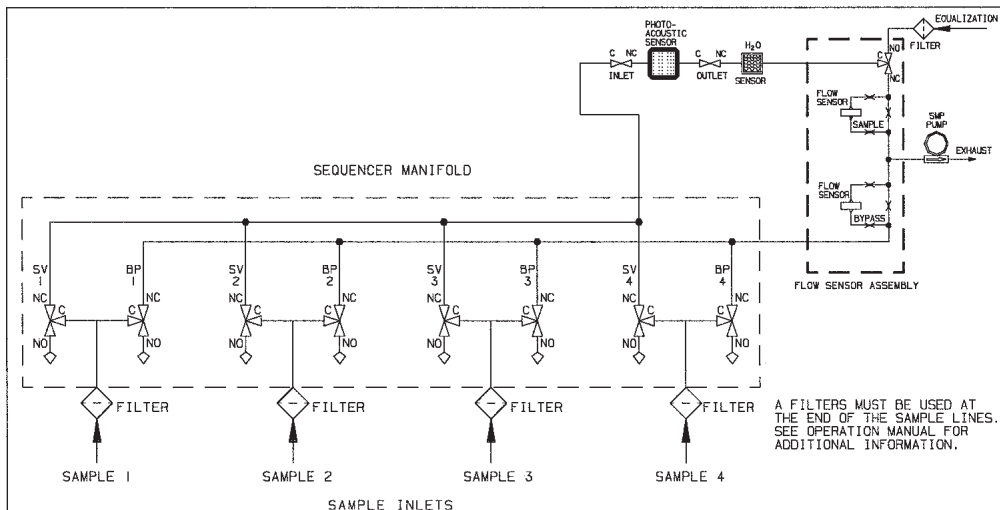
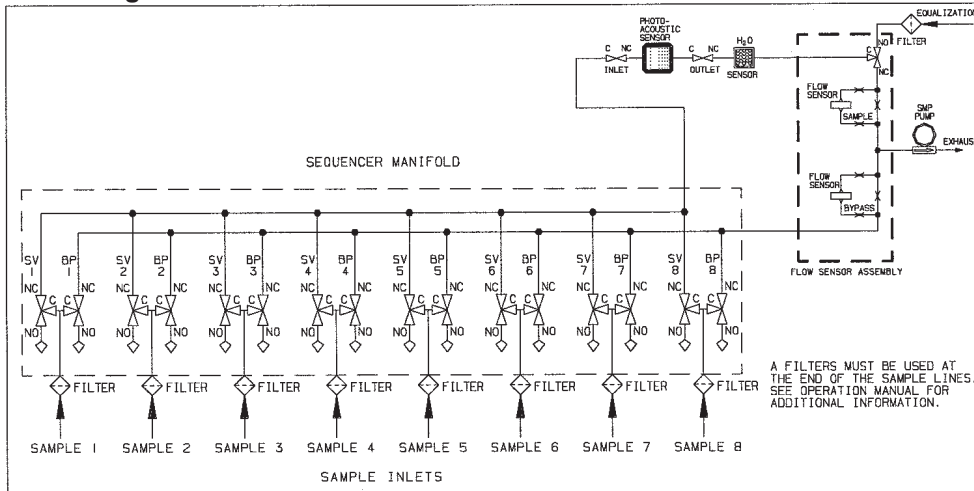

Figure 35c—Eight Channel Model



Technical Specifications

Mechanical

Enclosure

Hinged door with 2 quarter-turn latches. Beige with black face plate.

Mounting

Four (4) mounting tabs provided on back of enclosure.

Weight

Single Channel Unit = 42 lbs.

8-channel scanner unit = 45 lbs.

Sample Flow Rate

0.75 liters per minute (LPM) minimum with maximum tubing length.

Maximum Tubing Length

(Sample and exhaust lengths combined)

150 feet with 1/4" OD, 1/8" ID

500 feet with 1/4" OD, 3/16" ID

Sample Tubing Connections

1/4" OD

Dimensions

18" High, 16" Wide, 7" Deep

Electrical

Inputs

Power Input- The refrigerant monitor will operate from a source of AC power of 100 VAC to 240 VAC, 50 to 60 HZ. Power input not to exceed 80 watts in a single channel operation.

Auxiliary Input- A 4 to 20 mA analog signal can be sent to the monitor from another device. Use 18 AWG, twisted pair wire, maximum length is 250 feet.

Remote Reset- An input is available to remotely reset latched alarm relay. On activation, all latched alarms will be reset. Maximum distance from monitor to contacts is 250 feet using 18 AWG twisted pair wire.

Outputs

Analog- Two analog outputs, a 4-20 mA and 0-10 VDC, are provided to indicate refrigerant gas concentration. These outputs may be used independently and simultaneously.

Ranges selectable by software:
0 to 100 PPM
0 to 1000 PPM

The resolution on each range is 1 PPM.

4 to 20 mA: Current sourcing, 1000 ohms maximum load.

0 to 10 VDC: Sources voltage to 2K ohms maximum load.

Relays- Three refrigerant level alarm relays (Caution, Warning and Alarm) and one trouble alarm (Normally Energized) relay are provided. Each relay has terminals for; Normally open (N/O), Common (C) and Normally closed (N/C). All relays are form C, SPDT which can be wired to either close or open its contacts in an alarm condition. The contacts are rated for 240 VAC, 8 amps resistive load.

Technical Specifications

Gas Sensing Characteristics

Gas Sensitivity

Standard factory calibration for HCFC-123, CFC-11, HCFC-22 and HFC-134a. Calibrations for other refrigerants are available.

Alarm Levels

Alarm levels are software adjustable in steps of 1 PPM over the following ranges:

All Refrigerants	Low Alarm Limit	High Alarm Limit
Caution	3 ppm	Warning Level -1
Warning	Caution Level + 1	Alarm Level - 1
Alarm	Warning Level +1	1000 PPM

Factory Default Values are:

Refrigerant	Caution	Warning	Alarm
HCFC-123	50	150	500
CFC-11, HCFC-22, HFC-134a, CFC-12, CFC-113, CFC-114, CFC-500, CFC-502	50	150	1000

Stability

The monitors precision over a period of time.

0-50 PPM, +/- 1 PPM
51-1000 PPM, +/- 10% of reading

Short Term Noise

An output signal not directly related to the signal produced by the presence of a refrigerant gas. +/- 1 PPM over a 10 minute period.

Linearity

Describes the accuracy of the instrument, under set environmental conditions, over its operating range.

0-50 PPM, +/- 1 PPM
51-1000 PPM, +/- 10% of reading.

These values were determined at environmental conditions of 25°C, 14.7 psia, and 50% RH.

Warm-up Time

20 minutes typical at 70° F ambient
24 hours maximum.

Technical Specifications

Response Time

70 seconds for a 90% step change at the monitor input.

105 seconds for a 90% step change with 150 feet of sampling tubing.

13 minutes for a 90% step change with 500 feet of sampling tubing.

Additional scanner dwell time is 30 seconds per point. If a reading is observed greater than the threshold value, the scanner will dwell at that point for an additional 60 seconds.

Operating Temperature Range

0°C - 50°C (32°F - 122°F)

Temperature Effect

The gas response displayed by the instrument (PPM) can change (+/-) 0.3% for each degree (C) that the instrument is operating above/below the temperature at which the instrument was last calibrated.

Humidity

0 to 95% R.H. Non condensing, over the operating temperature range.

Operating Pressure

Ambient Atmospheric

Agency Listing

The following refrigerant monitor gas calibrations are listed under UL 2075.

TRANE MODEL	R-11
RMWE	R-12
GAS MONITORS	R-113
EVALUATED BY	R-114
UNDERWRITERS	R-500
LABORATORIES	R-502
INC.	R-123
	R-22
	R-134a